



INSTALLATION INSTRUCTIONS FOR CMP CABLE GLAND TYPE PXSS2K-REX

FOR TERMINATION OF UNARMoured, BRAIDED CABLES AND EXTRA HARD CORD
USEAGE CABLES, FOR USE IN EXPLOSIVE ATMOSPHERES.

INCORPORATING EU DECLARATION OF CONFORMITY TO DIRECTIVE [2014/34/EU]

CABLE GLAND TYPE PXSS2K-REX



Cable Gland Selection Table

TECHNICAL DATA

CABLE GLAND TYPE : PXSS2K-REX
INGRESS PROTECTION : IP66, IP67, IP68
PROCESS CONTROL SYSTEM : BS EN ISO 9001
 : ISO/IEC 80079-34:2011

EXPLOSIVE ATMOSPHERES CLASSIFICATION

ATEX CERTIFICATION No : SIRAI3ATEX1072X, SIRAI3ATEX4078X
ATEX CERTIFICATION CODE : Ⓜ II 2G, II 1D, Ex d IIC Gb, Ex e IIC Gb, Ex ta IIIC Da
 : Ⓜ II 3G Ex nR IIC Gc, ⓂIM2 Ex d I Mb, Ex e I Mb

IECEX CERTIFICATION No : IECEX SIR.13.0027X
IECEX CERTIFICATION CODE : Ex d IIC Gb, Ex e IIC Gb, Ex nR IIC Gc, Ex ta IIIC Da, Ex d I Mb, Ex e I Mb
cCSAus CERTIFICATION No : 2288626
cCSAus CERTIFICATION CODE : Class I, Groups A, B, C and D; Class II, Div. 2, Groups F and G; Class III, Div. 2; Type 4X; Oil Resistance II
 : Class I, Zone 1 AEx d IIC Gb, AEx e IIC Gb, Class I, Zone 2 AEx nR IIC Gc, Class I, Zone 20 AEx ta IIIC Da

INSTALLATION INSTRUCTIONS

Installation should only be performed by a competent person using the correct tools. Spanners should be used for tightening. Read all instructions before beginning installation.

SPECIAL CONDITIONS FOR SAFE USE

1. According to the CEC wiring code, connectors with metric threads are only suitable for Areas Classified in ZONES unless fitted with an approved Metric to NPT thread conversion adaptor.
2. Wiring method for type of cables that can be used in Class I, Div. 1, 2, and Class I, Zone 1, 2, Classified Areas according to 60079-14 installation wiring method restrictions.
3. When assembled for fitting to flexible conduit, the conduit shall be effectively clamped to prevent twisting and pulling.
4. CAUTION - To reduce the risk of flame propagation, fittings with ISO metric threads require:-
a) 5 full threads engaged for gas groups C and D
b) 10 full threads engaged for gas groups A and B
5. When the connector is supplied with metric entry threads, a CMP Entry Thread Washer should be fitted between the connector and the enclosure to prevent the ingress of moisture or dust into the enclosure. Thread tape must not be applied to the threads.
6. Before installing the connector, ensure that the connector thread forms and the enclosure thread form are compatible.

ACCESSORIES

The following accessories are available from CMP Products, as optional extras, to assist with fixing, sealing and earthing :-
Locknut | Earth Tag | Serrated Washer | Entry Thread (I.P.) Sealing Washer | Shroud *

Cable Gland Size	Available Entry Threads (Alternate Metric Thread Lengths Available)				Number of Cores	Diameter Over Conductors	Cable Bedding Diameter			Overall Cable Diameter			Across Flats	Across Corners	Protrusion Length	Combined Ordering Reference (*Brass Metric)			Shroud	Cable Gland Weight (Kgs)
	Standard		Option				Max	Min	Max	Max	Max	Max				Size	Type	Ordering Suffix		
	Metric	Thread Length (Metric)	NPT	Thread Length (NPT)																
20x16	M20	15.0	1/2"	19.9	3/4"	11	8.6	8.6	3.1	8.6	30.0	33.0	53.1	20516	PXSS2KREX	1RA	PVC06	0.200		
205	M20	15.0	1/2"	19.9	3/4"	11	11.7	11.7	6.1	11.7	30.0	33.0	53.1	205	PXSS2KREX	1RA	PVC06	0.200		
20	M20	15.0	1/2"	19.9	3/4"	11	12.6	12.9	6.5	14.0	30.0	33.0	54.2	20	PXSS2KREX	1RA	PVC06	0.200		
25	M25	15.0	3/4"	20.2	1"	21	17.5	17.9	11.1	20.0	36.0	39.6	60.0	25	PXSS2KREX	1RA	PVC09	0.330		
32	M32	15.0	1"	25.0	1 1/4"	38	23.6	23.9	17.0	26.3	41.0	45.1	61.1	32	PXSS2KREX	1RA	PVC10	0.590		
40	M40	15.0	1 1/4"	25.6	1 1/2"	59	30.0	30.3	22.0	32.1	50.0	55.0	62.4	40	PXSS2KREX	1RA	PVC13	0.560		
50S	M50	15.0	1 1/2"	26.1	2"	89	36.6	36.9	29.5	38.2	55.0	60.5	65.2	50S	PXSS2KREX	1RA	PVC15	0.660		
50	M50	15.0	2"	26.9	2 1/2"	89	41.0	41.3	35.6	44.0	60.0	66.0	67.6	50	PXSS2KREX	1RA	PVC18	0.730		
63S	M63	15.0	2"	26.9	2 1/2"	115	47.9	48.4	40.1	49.9	70.0	77.0	71.1	63S	PXSS2KREX	1RA	PVC21	1.070		
63	M63	15.0	2 1/2"	39.9	3"	115	53.7	54.0	47.2	55.9	75.0	82.5	70.4	63	PXSS2KREX	1RA	PVC23	1.060		
75S	M75	15.0	2 1/2"	39.9	3"	140	59.9	60.2	52.8	61.9	80.0	88.0	75.3	75S	PXSS2KREX	1RA	PVC25	1.300		
75	M75	15.0	3"	41.5	3 1/2"	140	64.3	64.2	59.1	67.9	85.0	93.5	74.9	75	PXSS2KREX	1RA	PVC27	1.300		
90	M90	24.0	3 1/2"	42.8	4"	200	75.3	75.6	66.6	79.4	108.0	118.8	94.8	90	PXSS2KREX	1RA	PVC31	3.020		
100	M100	24.0	4"	44.0	5"	200	85.6	85.9	76.0	90.9	123.0	135.3	86.3	100	PXSS2KREX	1RA	LSF33	4.000		

*For material options add the following suffix to the Ordering Reference; Brass (no suffix required); Nickel Plated Brass 'S'; 316 Grade Stainless Steel '4'; Copper Free Aluminium '1'
For NPT options add the following digits to the material suffix; 1/2" = 31, 3/4" = 32, 1" = 33, 1 1/4" = 34, 1 1/2" = 35, 2" = 36, 2 1/2" = 37, 3" = 38, 3 1/2" = 39, 4" = 310 (Brass requires prefix '0')
Examples: 32PXSS2KREX1RA534 = Nickel Plated Brass 1-1/4" NPT, 50SPXSS2KREX1RA035 = Brass 1-1/2" NPT, 25PXSS2KREX1RA432 = Stainless Steel 3/4" NPT, 20PXSS2KREX1RA5 Nickel Plated Brass M20
Dimensions are displayed in millimetres unless otherwise stated

CMP Products Limited on its sole responsibility declares that the equipment referred to herein conforms to the requirements of the ATEX Directive 2014/34/EU and the following standards:-

EN 60079-0:2006, EN 60079-1:2007, EN 60079-7:2007, EN 60079-15:2005, BS 6121:1989, EN 62444:2013, EN 61241-0:2007, EN 61241-1:2004

David Willcock

David Willcock - Certification Engineer - (Authorised Person)
CMP Products Limited, Cramlington, NE23 1WH, UK
24th June 2015



CE 0518

Notified Body: Sira Certification Service, Unit 6, Hawarden Industrial Park, Hawarden, CH5 3US, UK

www.cmp-products.com



Logo's shown for illustration purposes only. Please check certification for details

INSTALLATION INSTRUCTIONS FOR CMP CABLE GLAND TYPES PXSS2K-REX

CABLE GLAND COMPONENTS - It is not necessary to dismantled the cable gland any further than illustrated below

- 1. Resin
- 2. Entry Component "A"
- 3. Compound Tube
- 4. Resin Dam
- 5. Spacer
- 6. Main Item
- 7. Skid Washer
- 8. Outer Seal
- 9. Outer Seal Nut
- 10. Thread Shield

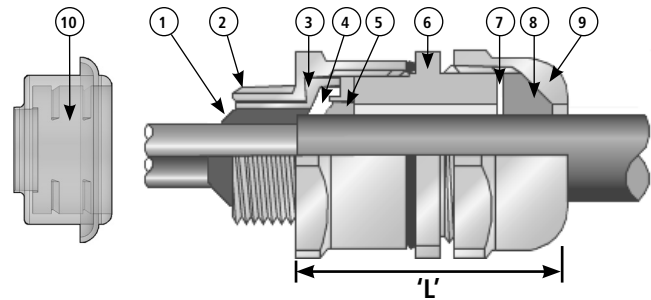

PLEASE READ ALL INSTRUCTIONS CAREFULLY BEFORE BEGINNING THE INSTALLATION

1. Remove any bedding or fillers from around the cable cores. If the cable cores have screens, these should be unravelled and then twisted together to form a single core. This single core and any drain wires present should be sleeved with some heat shrink tubing.

Electrical tape **MUST** be wrapped around the tips of the cable cores. This is to ensure the cable cores are together and also to cover any sharp edges that could potentially tear the Resin Dam during installation.

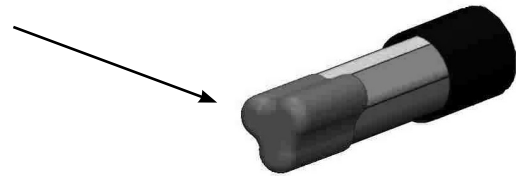

2. Feed the cable carefully into the entry item (2) through the resin dam (4). Reassemble the gland and adjust the position of the cable if necessary to that the outer sheath just protrudes through the resin dam. (Use length 'L' as a guide for positioning the cable). Tighten the outer seal nut enough to secure the gland. Make sure thread shield is in place.

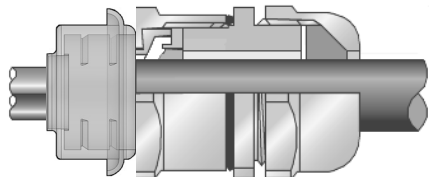

Note: If the outer sheath is too large to pass through the spacer then wrap some electrical tape around the cores at the point they pass through the resin dam.

3. Refer to 'RapidEx Resin' assembly instructions to fill the connector Compound Tube with the required amount of resin. The resin should not be mixed or applied at temperatures below 5°C (40°F). If the general ambient temperature is below 5°C (40°F) please follow the instructions on CMP TDS 613 before proceeding (available on CMP website)

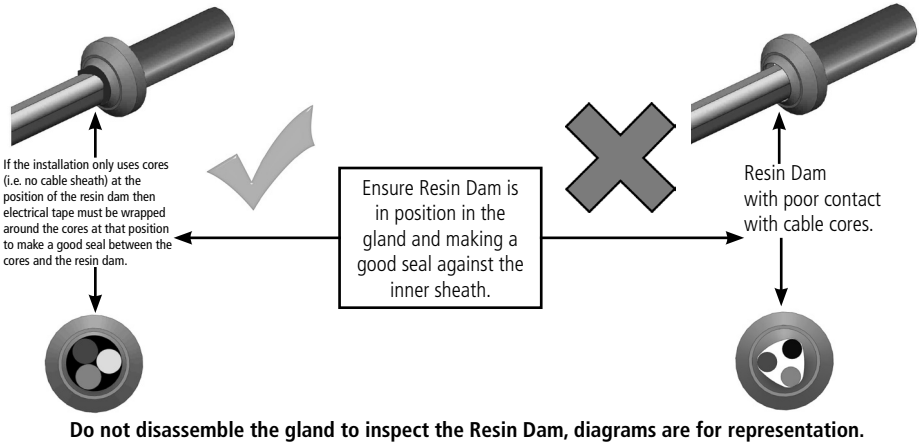

4. Once the resin has cured remove the thread shield (10). Loosen the outer seal nut, remove the main item (6) and outer seal nut assembly (7,8,9) from the entry item (2). Fit the entry item into the equipment.

5. Re-install the cable assembly into the entry item and fully tighten the main item (6) onto the entry item (2). Tighten the outer seal nut (9) until it comes to an effective stop. This will occur when :-

- A) The outer seal nut (9) has clearly engaged the cable and cannot be further tightened without the use of excessive force by the installer.
- B) The outer seal nut (9) is metal to metal with the main item (6).

