

EUROMOLD®

ACCESSORIES FOR MEDIUM
VOLTAGE POWER CABLES
TECHNICAL INFORMATION

CATALOGUE 2017

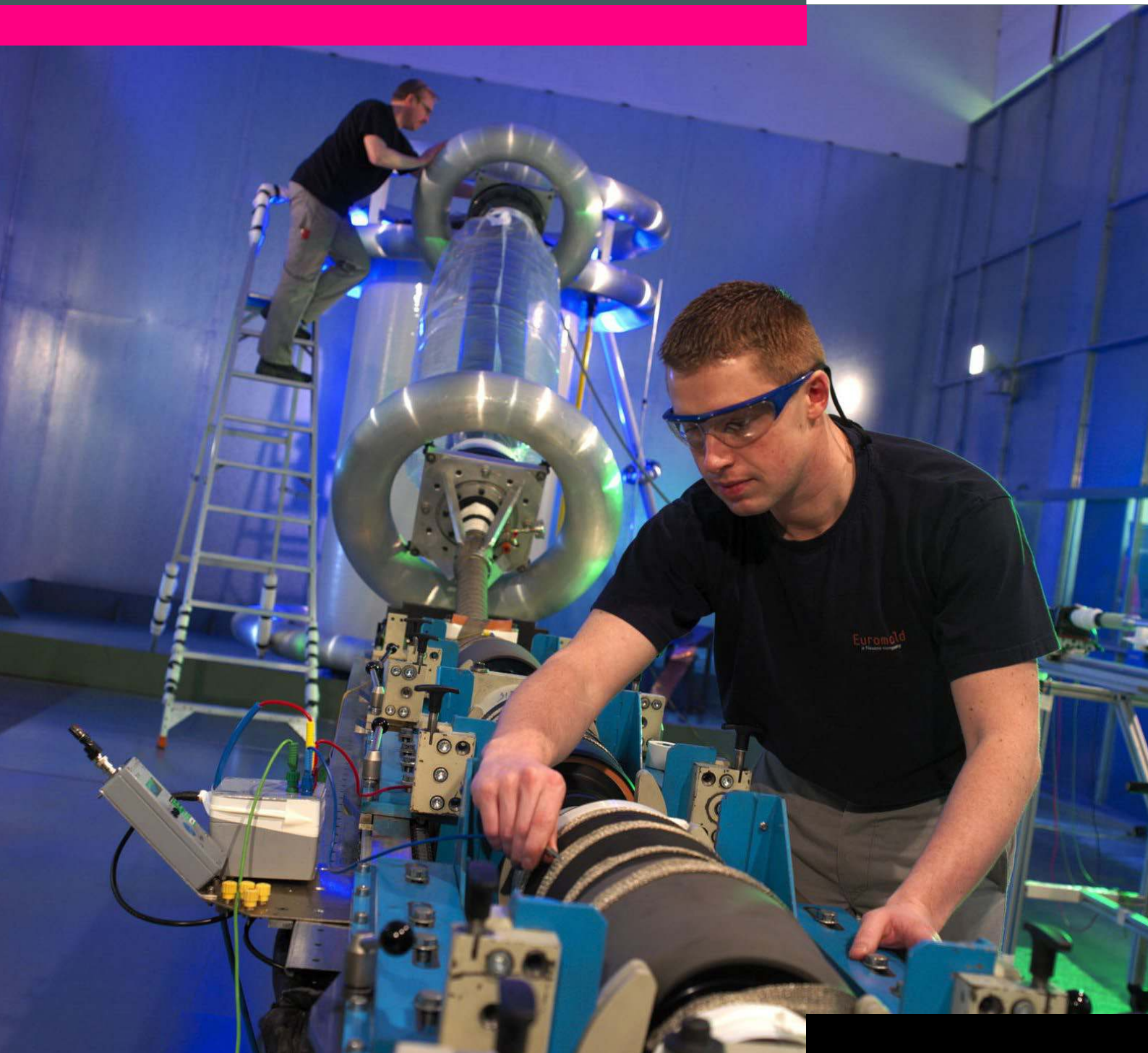
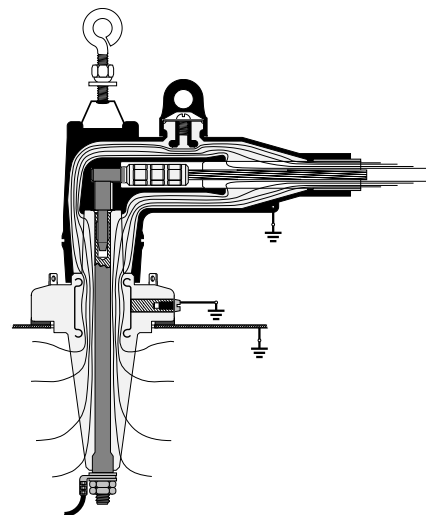

THORNE &
DERRICK
INTERNATIONAL

Thorne & Derrick
+44 (0) 191 410 4292
www.powerandcables.com

Nexans
BRINGS ENERGY TO LIFE

NEXANS NETWORK SOLUTIONS DIV. EUROMOLD

COMPANY PRESENTATION



EUROMOLD

Euromold is the leading European specialised designer, manufacturer and distributor of prefabricated cable accessories for medium voltage energy distribution. Euromold provides a complete range of accessories for underground cables: premoulded EPDM rubber connectors for cables and epoxy bushings for transformers and switchgear, as well as a large range of cold-shrinkable terminations and joints from 12 to 42 kV.

Euromold is also the manufacturer of electrical components for the high voltage accessories of the Nexans group.

ISO 9001 Certificate

Since 1992, Euromold's commitment to quality is demonstrated by its ISO 9001 certification.

International standards

All our products meet the International standards like CENELEC HD 629.1, CENELEC EN 50180, IEC 60137, IEC 60502-4... or country specifications. Official certificates, CESI, KEMA, ATEX... prove the conformity of our products. Long duration tests of existing or new products are continuously performed in our test fields.

Laboratory accreditation

Since June 2000, Euromold's independent ELAB laboratory obtained the BELAC accreditation no.144-TEST conform with the European standards for laboratories ISO 17025 for electrical testing of low and medium voltage cable accessories according to the international standards EN 50393, IEC 60502-4, IEC 61442 and HD 629.



While every care is taken to ensure that the information contained in this publication is correct, no legal responsibility can be accepted for any inaccuracy. Nexans Network Solutions N.V. - Div. Euromold reserves the right to alter or modify the characteristics of its products described in this catalogue as standards and technology evolve.

TECHNICAL INFORMATION

TABLE OF CONTENTS

- Certifications
- Material properties
- Electrical stress
- Screen earthing device
- Overall dimensions of connectors
- Dimensions and ratings of bushings
- Electrical ratings
- Test sequences
- Jumpers and test leads
- References
- Enquiry sheet

CERTIFICATIONS

QUALITY CERTIFICATION

Euromold is committed to providing the highest quality cable accessories available. To ensure high reliability in use, essential for products that must last for at least 25 years, Euromold products are tested at all stages of manufacturing. Each and every product is electrically tested before being distributed. This way, the quality and safety of the products is guaranteed.

At Euromold, quality control takes place before, during and after production.

ISO 9001 QUALITY MANAGEMENT SYSTEM

Scope: development, design, manufacturing and sales of electrical cable accessories for medium and high voltage networks.

First approval date:
18 June 1992.

QUALITY ASSURANCE

Euromold's commitment to quality goes beyond the factory. Its Quality Assurance Program requires supplier quality agreements centring on Euromold specifications and embodying the concept of zero defects. The ISO 9001 certification is the seal of its commitment to excellence.

ISO 14001 ENVIRONMENTAL MANAGEMENT SYSTEM

Scope: development, design, manufacturing and sales of electrical cable accessories for medium and high voltage networks.

First approval date:
17 May 2013.

OHSAS18001 OCCUPATIONAL HEALTH AND SAFETY MANAGEMENT SYSTEM

Scope: development, design, manufacturing and sales of electrical cable accessories for medium and high voltage networks.

First approval date:
16 September 2013.



ATEX - DIRECTIVE 94/9/EC

Components intended for use on/in equipment or protective system intended for use in potentially explosive atmospheres:

K400TB(/G)	K804PB
K430TB(/G)	800SA
K440TB(/G)	K944TB
K676LRA(/G)	K400AR-6
K300PB	K900AR-1
300SA	K900AR-2
400PB-XSA	K900AR-3
K675BE	K900AR-4
K400AR-3	K480TB(/G)
K400AR-4	K489TB(/G)
400A-24B	K800PB(/G)
K400CP-SC	K809PB(/G)
K440CP	K400BE
K670AR-2	K480BE
K672T1	K784TB(/G)
K672TBC	K909TB(/G)
K680CP	K909PB(/G)
K484TB	K900BE



EC TYPE EXAMINATION CERTIFICATE

Component intended for use on/in equipment or protective system intended for use in potentially explosive atmospheres Directive 94/9/EC

(1) EC type examination certificate number: **ISSeP09ATEX023U**

(2) Component: **Prefabricated cable accessories for medium and high voltage networks.**

(3) Applicant - Manufacturer - Authorized representative for the Community: **Nexans Network Solutions N.V. - Div. EUROMOLD**

(4) Address: **Zuid III - Industrielaan 12
9320 Erembodegem
Belgique**

(5) This component and any acceptable variation thereto is specified in the schedule to this certificate and the documents therein referred to.

(6) ISSeP, notified body n° 0492 in accordance with article 9 of the Council Directive 94/9/EC of 23 March 1994, certifies that this component has been found to comply with the Essential Health and Safety Requirements relating to the design and construction of components intended for use in potentially explosive atmospheres given in annex II to the Directive.
The examination and test results are recorded in confidential report n° 08139.

(7) Compliance with the Essential Health and Safety Requirements has been assessed by compliance with:
IEC 60079-0: 2007 IEC 60079-7: 2005
IEC 60079-31: 2005

(8) The symbol "U" placed after the certificate number indicates that this certificate must not be mistaken for a certificate intended for an equipment or protective system. This partial certification may be used as a basis for certification of an equipment or protective system.

(9) This EC TYPE EXAMINATION CERTIFICATE relates only to the design and construction of the specified component. If necessary, other requirements of this directive may apply to the manufacture and supply of this component.

(10) The marking of the component shall include the following indications:
 II 2 G - Ex e IIC Gb
 II 2 D - Ex Ib IIC Da IFSX

Colfontaine, le 26.03.2009.
Lamber Mireel
Directeur

INSTITUT SCIENTIFIQUE DE SERVICE PUBLIC
Zoning N. Schroeven, route de Planchin
66-340 COLFONTAINE (Belgique)
Tel: +32 (0) 51 30 61 1 - Fax: +32 (0) 51 32 60 40 88

This certificate may only be reproduced in its entirety and without any charge, schedule included



1/3

ELAB

Elab is the Nexans laboratory accredited by BELAC to perform electrical test programmes according to the CENELEC HD 629.1 (IEC 60502-4) and EN 50393 standards for low and medium voltage power accessories from 300 volts up to 42 kV. The certificate number is BELAC no. 144-TEST.

The ISO 17025 standard prescribes the rules for the lab accreditation. It specifies the independency of the lab, the necessary competence, the organisation, the measurement accuracy and the handling of the instruments. Performing tests at accredited labs means that these tests are correctly performed, documented and repeatable in other accredited labs.



Organisme belge d'Accréditation
Belgische Accreditatieinstelling
Belgische Akkreditatieinstelling
Belgian Accreditation Body

Accreditation Certificate No. 144-TEST

In compliance with the provisions of the Royal Decree of 31 January 2006 setting up BELAC, the Accreditation Board hereby declares, that the test laboratory

NEXANS NETWORK SOLUTIONS NV DIV. EUROMOLD
ELAB
Industrielaan, 12 - Zuid III
9320 EREMBODEGEM - Belgium

has the competence to perform the tests as described in the annex which is an integral part of the present certificate, in accordance with the requirements of the standard NBN EN ISO/IEC 17025:2005. The present accreditation is the subject of regular surveillance in order to confirm the compliance with the accreditation conditions.

The Chair of the Accreditation Board BELAC,
Nicole Meurée-Vanlaethem
Nicole MEURÉE-VANLAETHEM

Issue date : **2016-09-15**
Validity date : **2021-06-14**
Original version of this certificate is in Dutch.



MATERIAL PROPERTIES

PROPERTIES OF EPDM AND SILICONE RUBBERS

For approximately 40 years Euromold has been formulating and moulding rubber compounds. The knowledge and skill gained over this extensive period has overcome many obstacles and are a great asset for the future. The resultant hydrocarbon-based elastomers have all advantages of general purpose rubbers but its performances excel in electrical strength and resistance to

environmental conditions. The silicone rubbers used by Euromold in its cold-shrinkable and slip-on terminations have been selected for their excellent tracking resistance as well as their unique hydrophobic properties.

ELECTRICAL PROPERTIES

Typical values	EPDM		Silicone
	Insulation	Conductive	Insulation
Dielectric strength (kV/mm)	33	-	24
Dielectric constant	2.7 to 3.1	-	2.6
Dissipation factor (x 10 ⁻³)	2.5	-	4
Volume resistivity at 20 °C (Ohm-cm)	10 ¹⁴	50	10 ¹⁵

OTHER PROPERTIES

Typical values	EPDM		Silicone
	Insulation	Conductive	Insulation
Specific gravity (kg/dm ³)	1.33	1.12	1.15
Tensile strength (N/mm ²)	4.8	11	8.5
Shore hardness (Shore A)	65	80	47
Elongation (%)	400	450	700
Abrasion resistance	good	excellent	poor
Heat ageing	good	good	good
Temperature range (°C)	-60 to +130	-60 to +130	-80 to +200
Resistance to:			
-U.V.	good	good	good
-Ozone	excellent	excellent	excellent
-Sunlight	outstanding	outstanding	outstanding
-Water absorption	very good	very good	excellent
-Solvent	poor	poor	poor
-Hydrocarbon oil	poor	poor	good
-Silicone oil	good	good	poor

RADIATION RESISTANCE

EPDM connectors are also installed in nuclear containment areas.

RESISTANCE TO MECHANICAL ABUSE

EPDM rubber has good resistance to compression, cutting, impact, tearing and abrasion over a wide temperature range.

OZONE/CORONA RESISTANCE

The outstanding resistance to corona is due to the ability of the EPDM rubber to withstand ozone and other chemical compounds formed by discharges and its resistance to heat.

CHEMICAL RESISTANCE

Products made from EPDM rubber resist attacks made by many acids, alkalis, detergents, phosphates, esters, ketones, alcohols and glycols. They give particularly outstanding service in the presence of hot water and high pressure steam. Like all hydrocarbon-based elastomers, EPDM is not resistant to hydrocarbon solvents and oils or chlorinated hydrocarbons.

RESISTANCE TO THE ENVIRONMENT

EPDM rubber has properties comparable with the best speciality elastomers in resistance to weather. Accelerated life and salt spray tests suggest excellent properties which have been proven in practice by more than 40 years experience in widely varied applications all over the world. Silicone rubber has outstanding long-term resistance to weather in aggressive environments (industrial, coastal and desert climates).

RESISTANCE TO WATER

Water has little effect on the properties of EPDM hydrocarbon rubber. Even long immersion in hot water results in minimal loss of tensile strength. Tests also show a very low degree of water absorption. Silicone rubbers retain their surface hydrophobicity which is a considerable advantage for outdoor applications.

INTERNATIONAL PROTECTION CLASS

By design, Euromold screened separable connectors are protecting live elements of the connection against ingress of dust and water. The protection class per IEC 60529 is IP67.

PROPERTIES OF SILICONE LUBRICANT

The high viscosity silicone grease has been chosen for both its lubrication and dielectric properties.

It is used as a lubricant when installing all premoulded rubber accessories on epoxy bushings as well as on the core insulation of dry cables.

Its selection is the result of several years of evaluation by Euromold of many types of silicone grease. Silicone grease displays a high level of long-term lubricating stability avoiding any ageing effects (e.g. the risk of sticking). It also offers excellent dielectric properties assuring good performance at high voltage interfaces. In addition, the grease contributes in making interfaces watertight. It is completely compatible with all premoulded rubber accessories as well as with polymeric insulated cables.

USES

Use of this grease has proven to be of value in the installation of accessories in series and for operations such as greasing interfaces after disconnection. The installation instructions included in each product package detail clearly the application of the silicone grease.

MATERIAL SAFETY DATA SHEET

Material safety data sheets can be obtained for all lubricants.

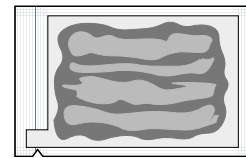

5 grams

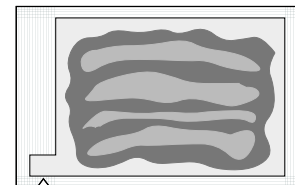

15 grams

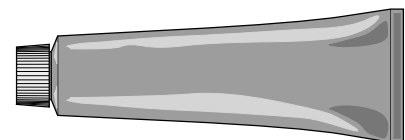

150 grams

ELECTRICAL STRESS

ELECTRICAL STRESS IN CABLES

The design and construction of screened power cables is primarily based on two types of electrical stress – a radial stress which can be represented by flux lines and a longitudinal stress on the surface of the insulation where the screen has been removed. (Fig. 1).

Fig. 1

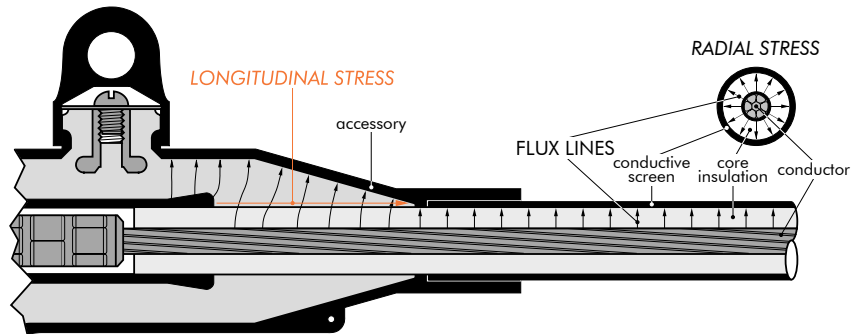

Fig. 2

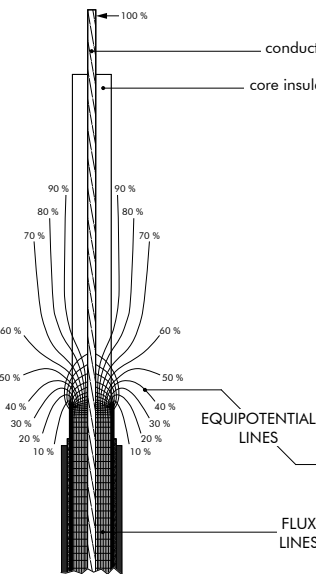

Fig. 3

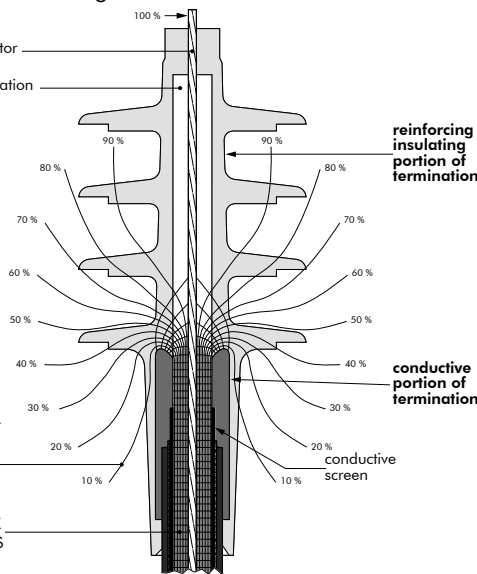

Fig. 4

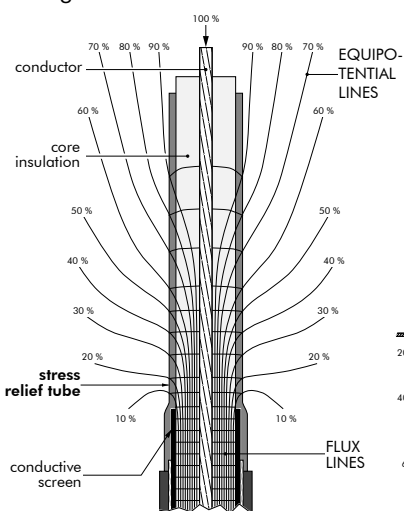
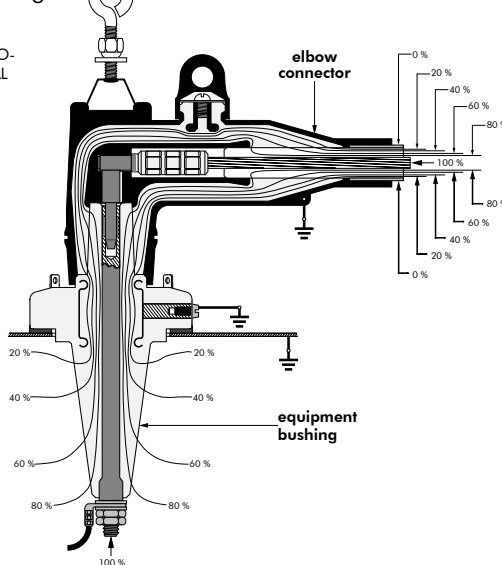

Fig. 5



ELECTRICAL STRESS RELIEF

When the semi-conductive screen is cut, the electrical field distribution changes radically. The surrounding air and the dielectric material in the vicinity of the cut screen become overstressed (Fig. 2) and breakdown of the cable will soon occur. To avoid this, we control the equipotential lines by installing a termination with a stress cone (Fig. 3), a termination with linear stress relief (Fig. 4) or a separable connector (Fig. 5) at the end of the screen.

The terminations will make sure that equipotential lines are sufficiently far apart when they finally emerge into the air and that they will not cause ionization. The separable connector keeps the equipotential lines inside the cable/connector assembly in a controlled way. This stress relief is automatically built into all the accessories by the precision moulding of conductive and/or insulating EPDM/silicone rubber.

THE VOLTAGE DETECTION POINT

The connectors manufactured by Euromold are provided with a capacitive test point: the voltage detection point (VD point). This enables a local check to confirm that the product is de-energised prior to disconnection (Use a high resistance test device - approx. 250 MΩ).

The capacitive test point consists of a metallic insert, moulded into the insulation and electrically connected to a convenient external terminal.

Under normal operating circumstances this terminal is earthed by its conductive rubber cap. The cap must be removed prior to testing. When applying the test device, a capacitive potential divider is effectively established.

The components of which are:

C_{tc} : between test point and line potential.

C_{tg} : between test point and earthed conductive screen.

C_m : representing the capacity of the detection apparatus.

The voltage available at the test point is directly proportional to the line voltage depending on the capacitance ratio.

Although relatively high voltages can be present on the test point after removing the conductive cap, the overall available energy is minimal and any potential would disappear instantaneously if accidentally touched by an operator or other personnel. The current transfer would be a fraction of a micro Ampere and imperceptible to human touch.

Key

- ① Conductive rubber cap
- ② Metallic insert (capacitive test point)
- ③ EPDM conductive screen (earth potential)
- ④ EPDM insulation
- ⑤ EPDM internal screen (line potential)
- ⑥ Metallic insert (line potential)

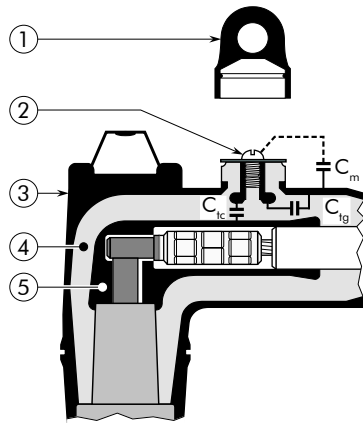
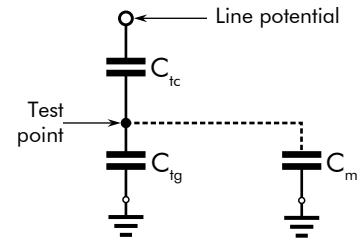

CONNECTORS:
152SR - 158LR
400LR

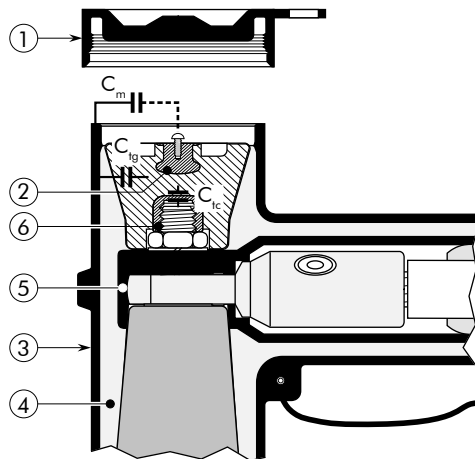

CONNECTORS:
480TB - 484TB - 489TB

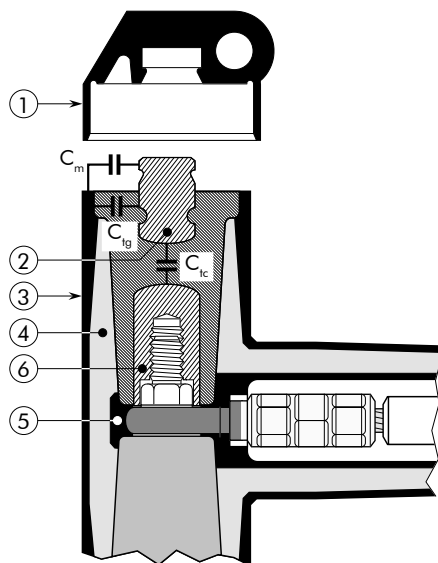

CONNECTORS:
909TB
676LRA
750LR - 775LR

APPLICATION

Terminations and separable connectors require additional earthing devices when installed on some types of cable. Please also check the product page in the catalogue.

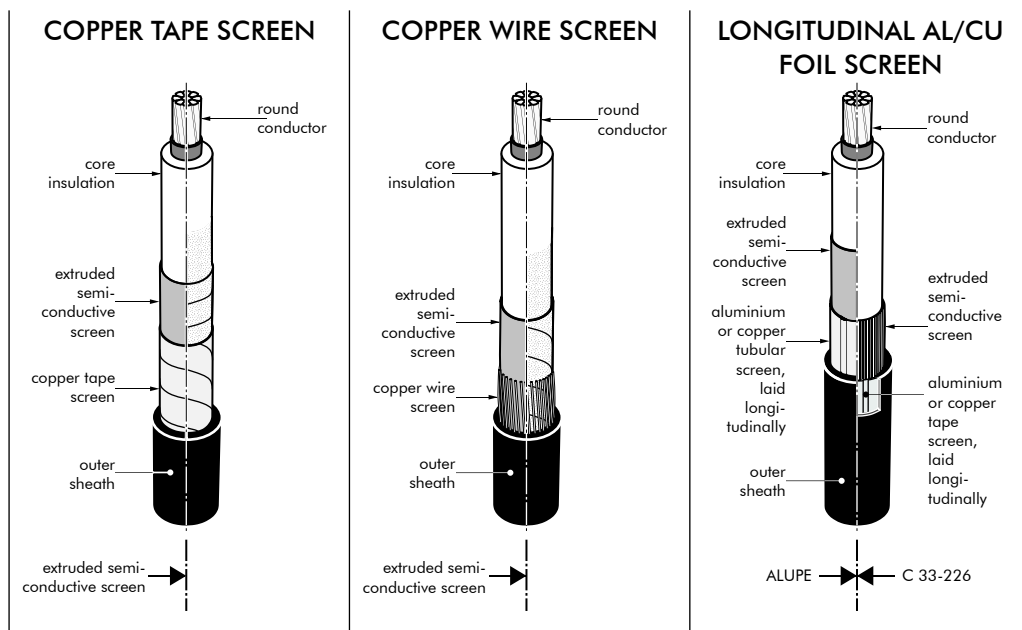

TERMINATIONS & CONNECTORS

Cable type →	Copper tape screen	Copper wire screen	Longitudinal Al/Cu foil screen	
Semi-conductive screen type →	Extruded	Extruded	Easy strip	Bonded
Conductor size (mm ²) ↓				
16-35	KIT MT	-		KIT 020
50-500	KIT MT	-		KIT 025
630-1200	KIT MT	-		KIT 050

KIT DESCRIPTION

KIT MT/RS

for use with copper tape screened cables.

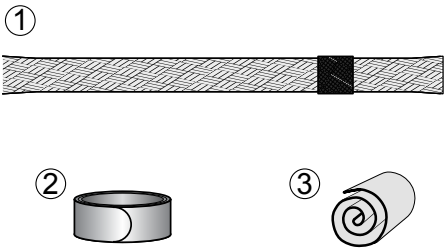

1. Tinned braid with solder block.
2. Constant force spring.
3. Roll of sealing mastic.

KIT MT

for use with copper tape screened cables.

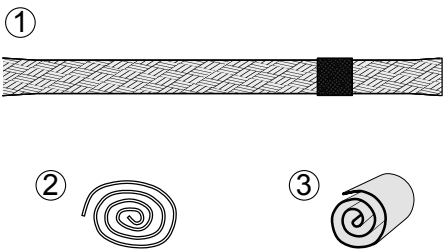

1. Tinned braid with solder block.
2. Tinned copper wire for earth braid cleating.
3. Roll of sealing mastic.

TSC

for use with fabric tape (graphite) cables.



A roll of semi-conductive tape.

KIT 020, KIT 025 & KIT 050

for use with longitudinal aluminium or copper foil screened cables.

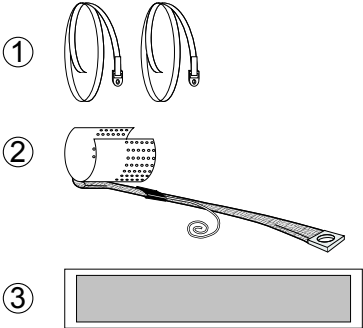

1. Two cleating collars.
2. Tinned copper earth braid with solder block, copper wire and terminal lug soldered to a tinned copper plate.
3. Strip of sealing mastic.

OVERALL DIMENSIONS OF SEPARABLE CONNECTORS

OVERALL DIMENSIONS

These diagrams show the dimensions of the connectors in assembled position and the minimum dimensions necessary to disconnect.

SEPARABLE CONNECTORS WITH INTERFACE A

152SR

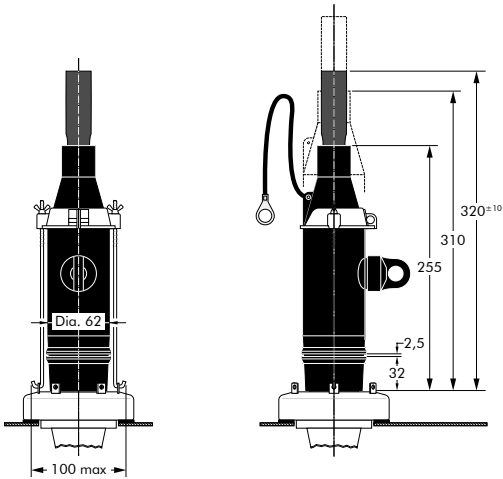

158LR

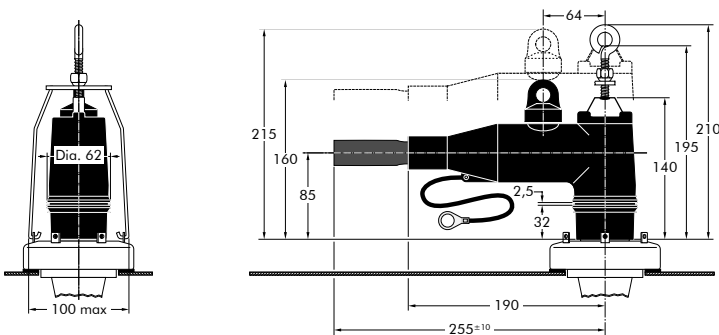

In mm.

SEPARABLE CONNECTORS WITH INTERFACE B

400LR

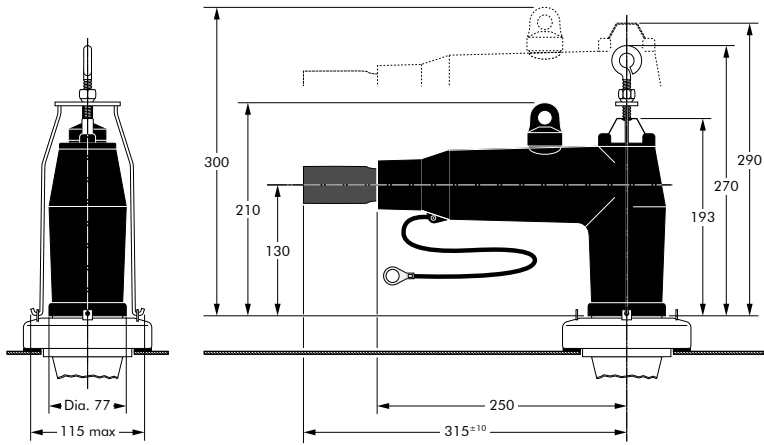

400TE

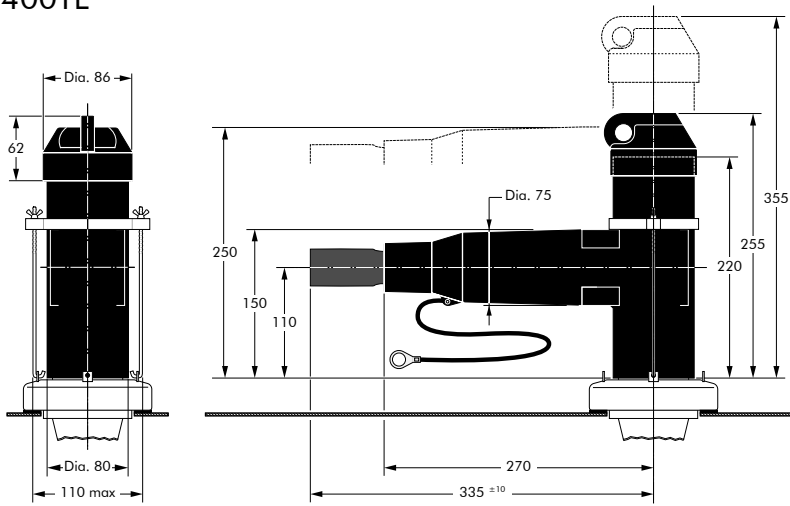

In mm.

SEPARABLE CONNECTORS WITH INTERFACE C

480TB

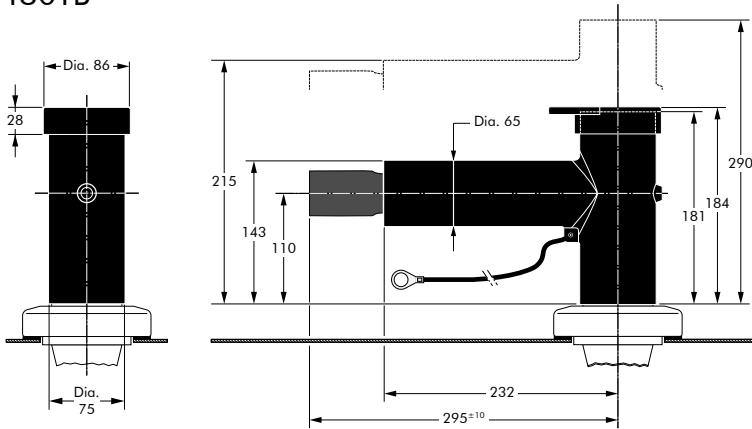

400LB

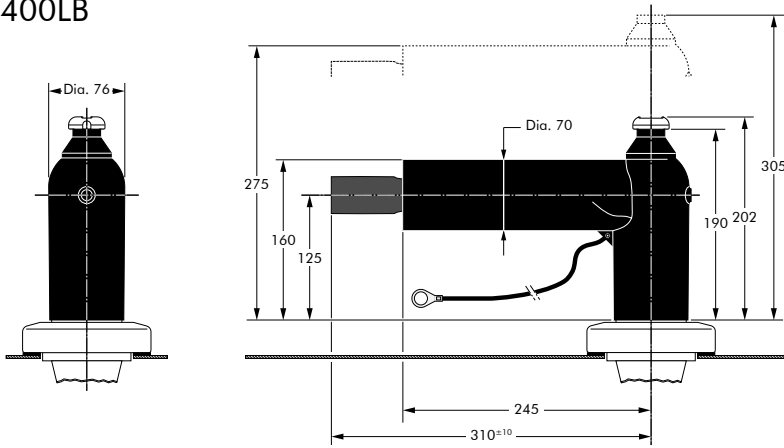

400TB

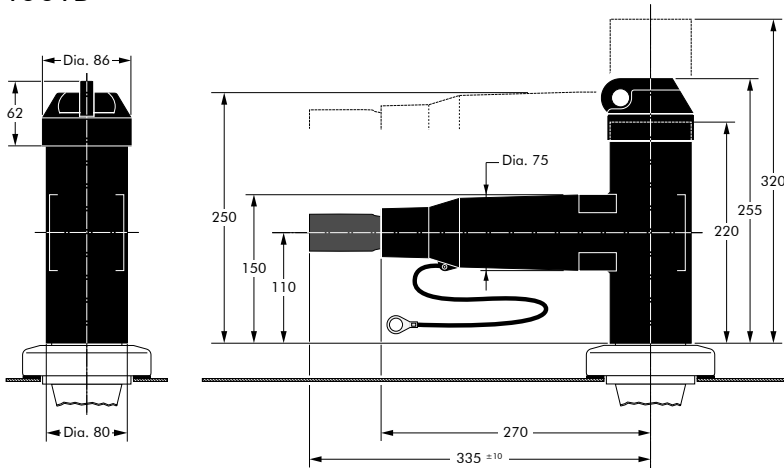

In mm.

484TB

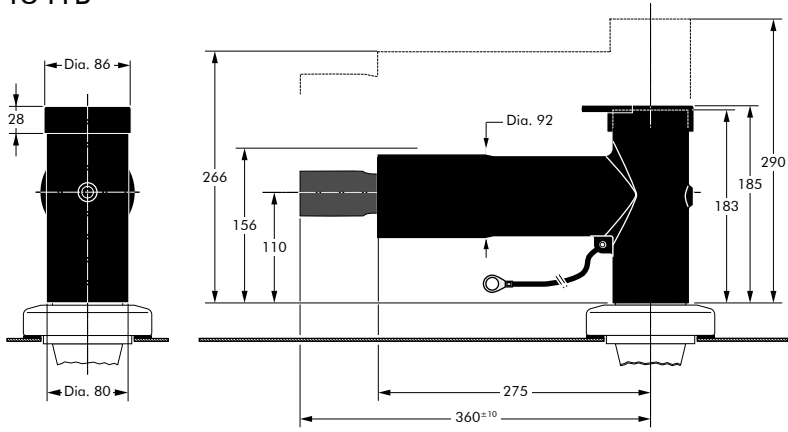

489TB

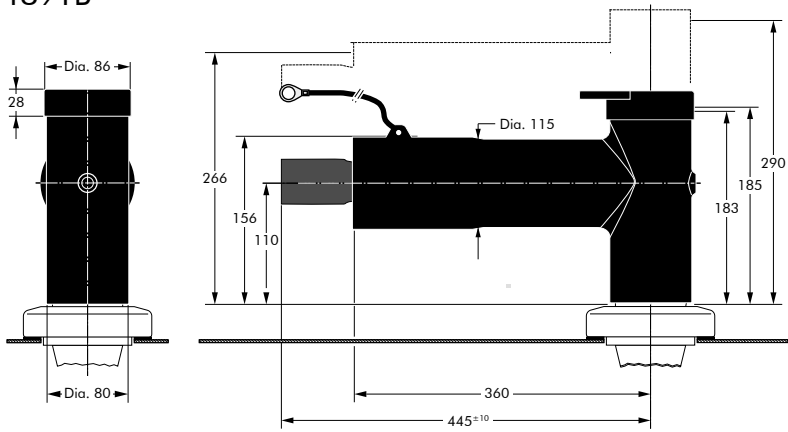

480TB+800PB

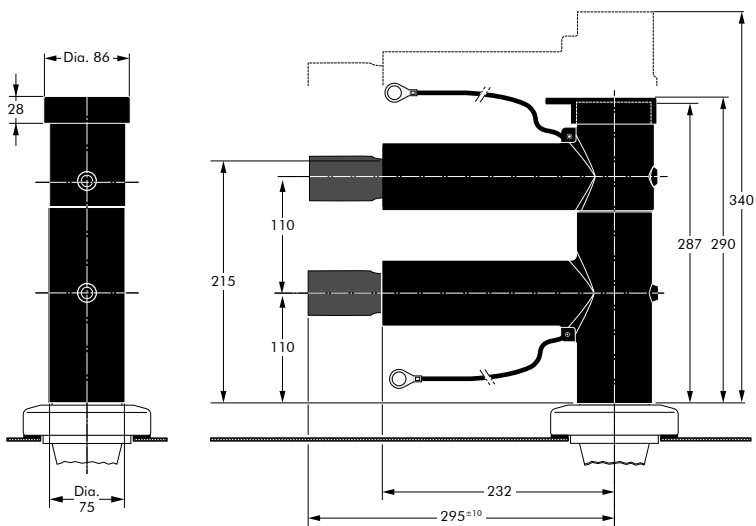

In mm.

440TB

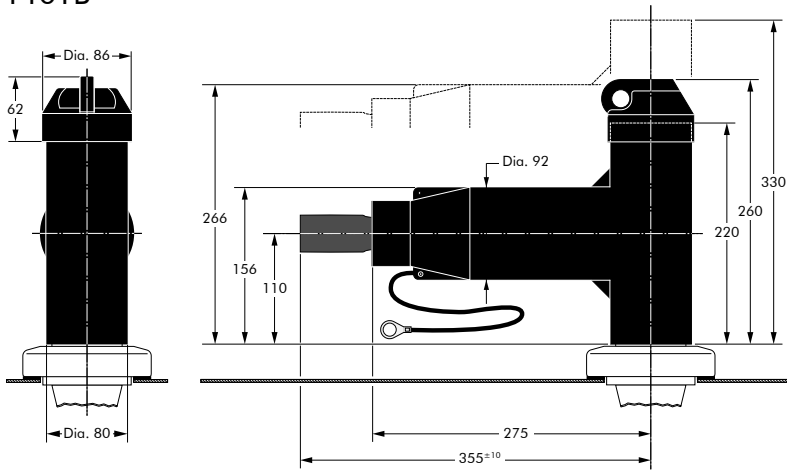

SEPARABLE CONNECTORS WITH INTERFACE D

676LRA

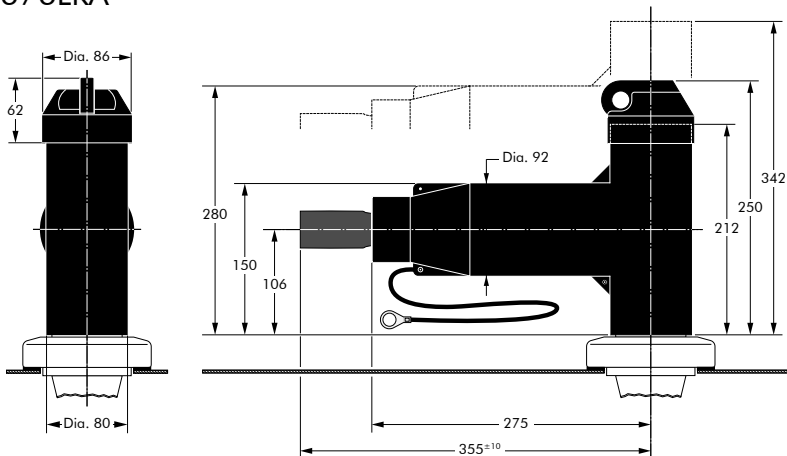

SEPARABLE CONNECTORS WITH INTERFACE E - 5/8"

784TB

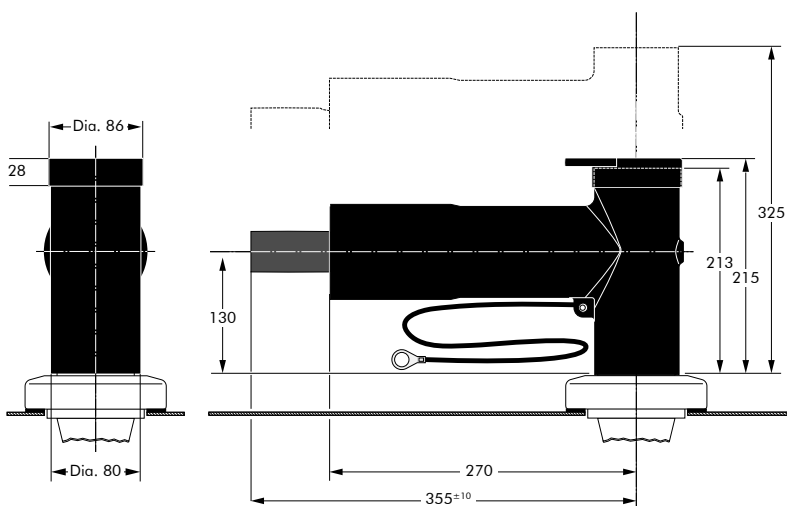

In mm.

**SEPARABLE CONNECTORS
WITH INTERFACE F**

909TB

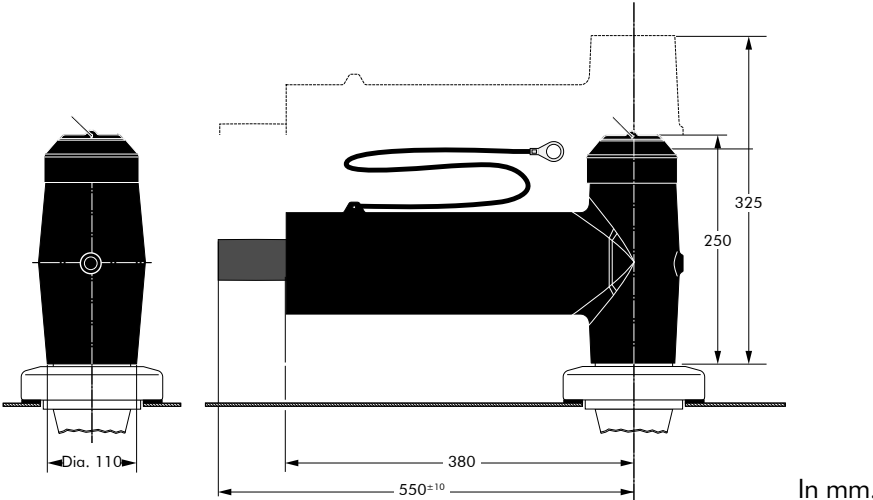

DIMENSIONS & RATINGS

OF EQUIPMENT BUSHINGS

DIMENSIONS

These diagrams show the dimensions of the interfaces of equipment bushings according to CENELEC standards EN 50180:2010 and EN 50181:2010.

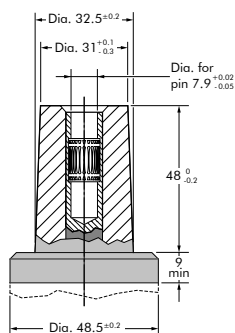

Interface A1

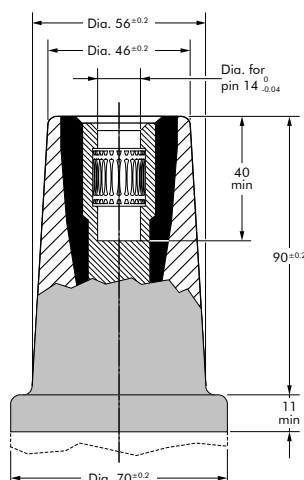

Interface B1 & B2

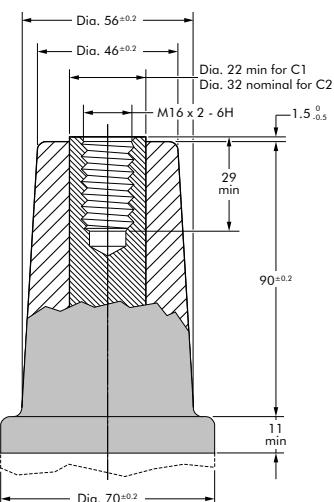

Interface C1 & C2

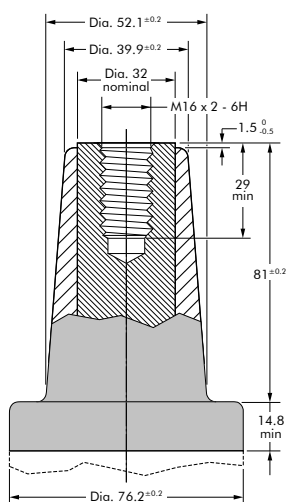

Interface D1 & D2

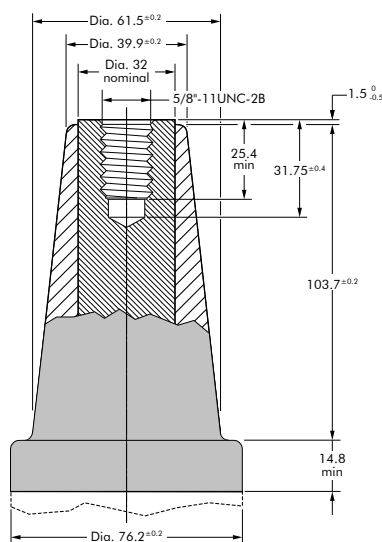

Interface E1 & E2

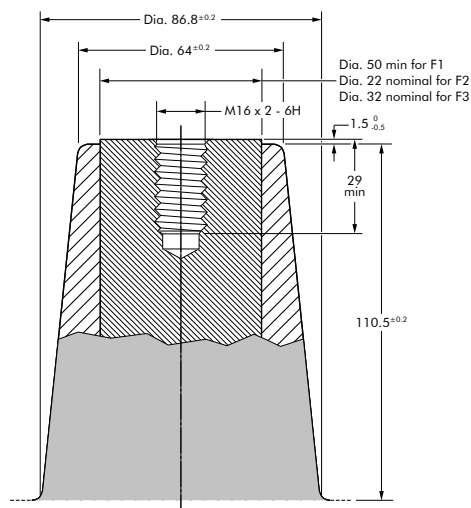

Interface F1, F2 & F3

In mm.

SHORT CIRCUIT RATINGS

Interface type	Contact type	Current rating (A)	RMS symm. (kA)			Peak asymm. (kA)	Voltage Um (kV)
			1 sec.	2 sec.	3 sec.		
A1	Pin and socket	250	12.5	9.0	7.5	31	24
B1	Pin and socket	250	12.5	9.0	7.5	31	36
B2	Pin and socket	400	16.0	11.3	9.2	40	36
C1	Bolted	630	28.0	19.7	16.1	70	36
C2	Bolted	1250	75.0	53.0	43.3	>150	36
D1	Bolted	800	50.0	35.3	28.8	125	24
D2	Bolted	1250	75.0	53.0	43.3	>150	24
E1	Bolted	800	50.0	35.3	28.8	125	36
E2	Bolted	1250	75.0	53.0	43.3	>150	36
F1	Bolted	2500	-	-	-	-	36
F2	Bolted	630	28.0	19.7	16.1	70	52
F3	Bolted	1250	75.0	53.0	43.3	>150	52

09/2017

ELECTRICAL RATINGS

APPLICATION

The voltage, current and routine test ratings mentioned below are at least at the same level of the CENELEC standards.

The actual maximum withstand level of the products are higher than these ratings.

For compliance with other standards, refer to our local representative.

VOLTAGE

U_0/U (U_m)	6/10 kV (12 kV)	6.35/11 kV (12 kV)	8.7/15 kV (17.5 kV)	12/20 kV (24 kV)	12.7/22 kV (24 kV)	18/30 kV (36 kV)	19/33 kV (36 kV)	20.8/36 kV (42 kV)
Partial discharge extinction max 10 pC (@ $2U_0$)	12 kV	12.5 kV	17.5 kV	24 kV	25 kV	36 kV	38 kV	42 kV
Impulse (1.2 x 50 μ s)	75 kV	95 kV	95 kV	125 kV	125 kV	170 kV	194 kV	200 kV
AC voltage 5'	27 kV	28.5 kV	39 kV	54 kV	57 kV	81 kV	85.5 kV	93.5 kV
DC voltage 15'	36 kV	38 kV	52 kV	72 kV	76 kV	108 kV	114 kV	125 kV

CURRENT

Current	Separable connectors & Bushings						Terminations & joints
	Interface type						
	A1/B1	B2	C1/F2	D1/E1	C2/D2/E2/F3	F1	
Continuous I_r	250 A	400 A	630 A	800 A	1250 A	2500 A	Same as cable
Overload (8 h in 24 h period)	300 A	600 A	800 A	1000 A	1500 A	-	Same as cable

ROUTINE TESTS

Test level	- (12 kV)	K (24 kV)	M (36 kV)	P (42 kV)
Partial discharge extinction @ 5 pC	11 kV	21 kV	31 kV	42 kV
AC voltage 1'	35 kV	55 kV	77 kV	85 kV

TEST SEQUENCES

FOLLOWING IEC 60137 and TS0030

EQUIPMENT BUSHINGS

Test sequences following IEC 60137 and internal test specification TS0030.

All our designs have been validated using this international standard. These values do not necessarily reflect the maximum levels.

Test reports are available upon request.

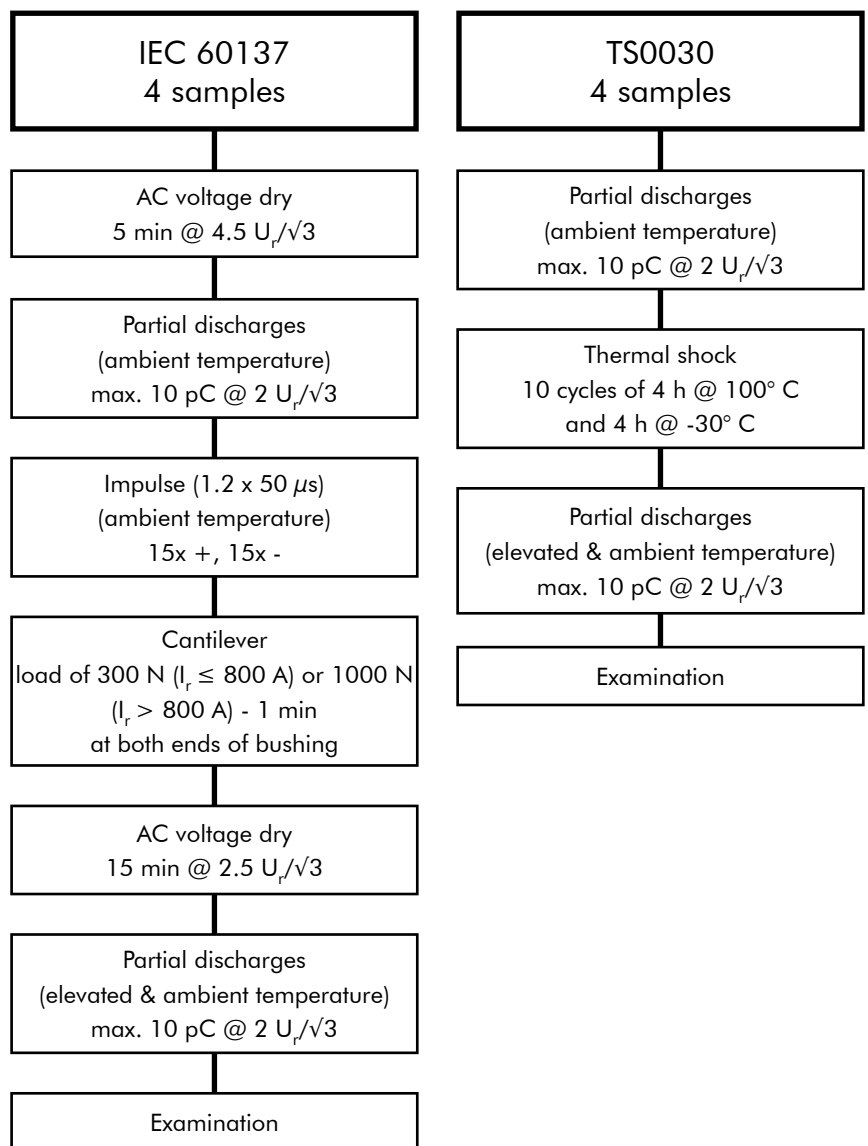

TERMINATIONS

Test sequences following HD 629.1 Table 3 (indoor terminations) and Table 4 (outdoor terminations). All our designs have been validated using this international standard. These values do not necessarily reflect the maximum levels. Test reports are available upon request.

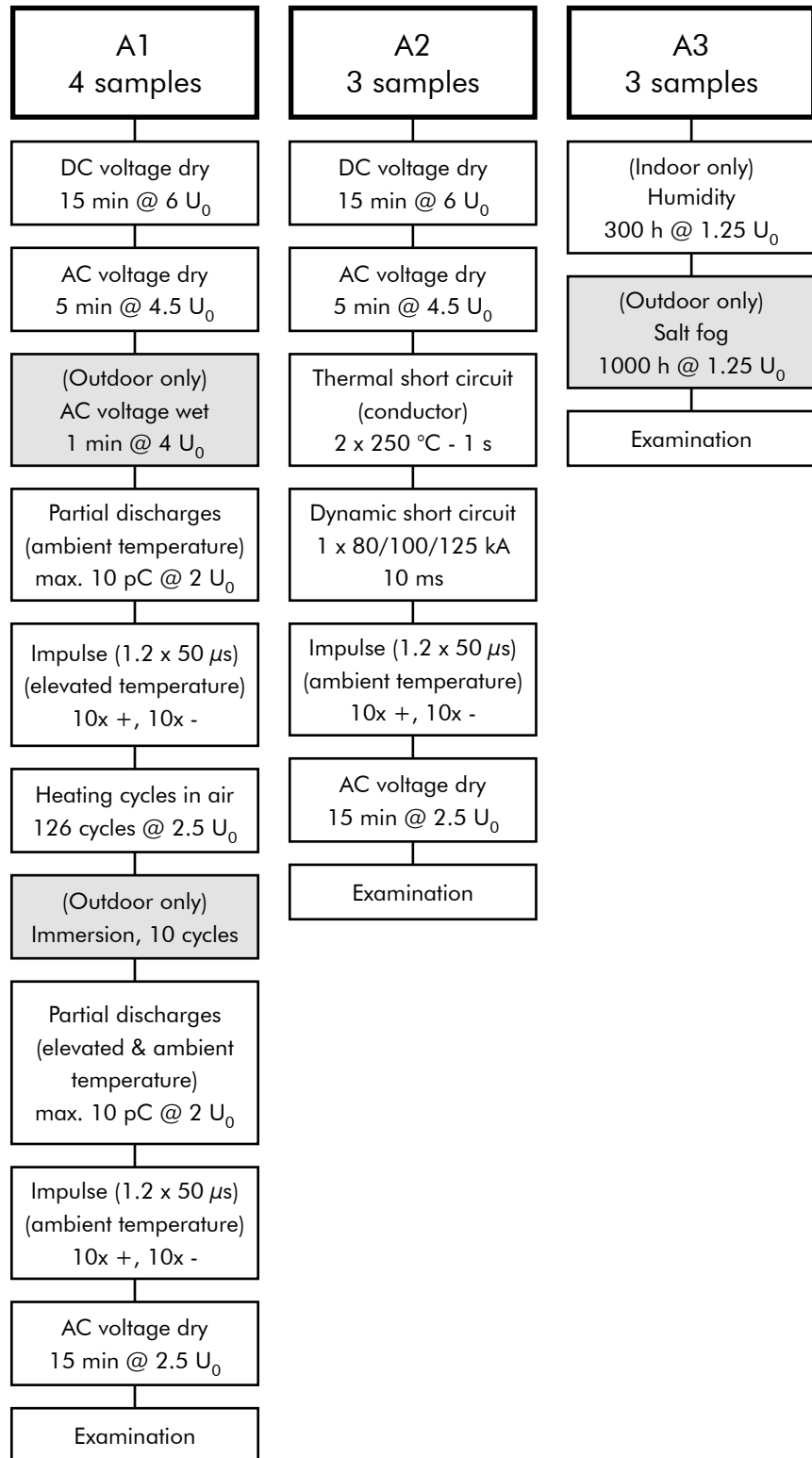

TEST SEQUENCES

FOLLOWING CENELEC 629.1

JOINTS

Test sequences following HD 629.1 Table 5.

All our designs have been validated using this international standard. These values do not necessarily reflect the maximum levels.

Test reports are available upon request.

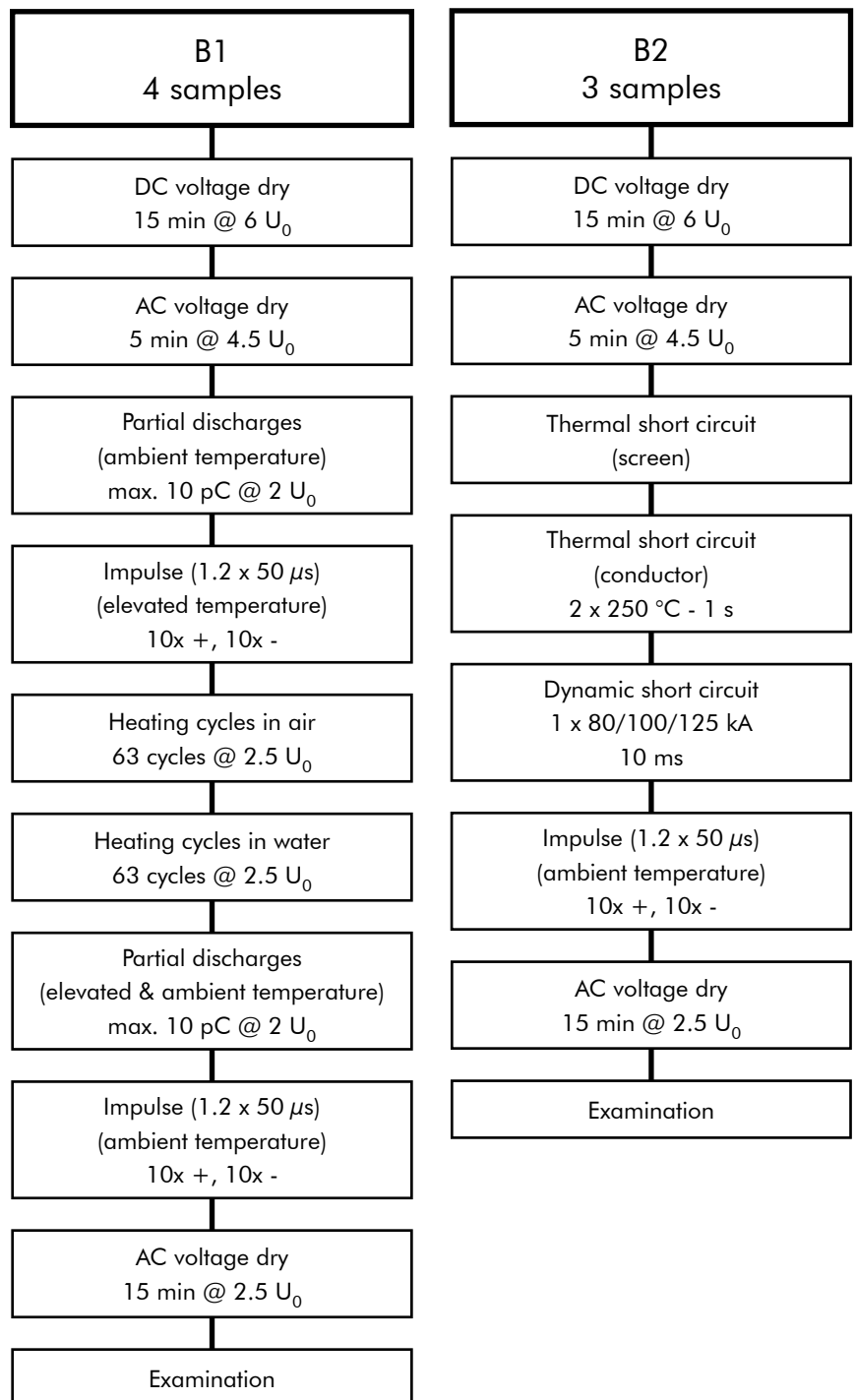

SCREENED SEPARABLE CONNECTORS

Test sequences following HD 629.1 Table 7.

All our designs have been validated using this international standard. These values do not necessarily reflect the maximum levels.

Test reports are available upon request.

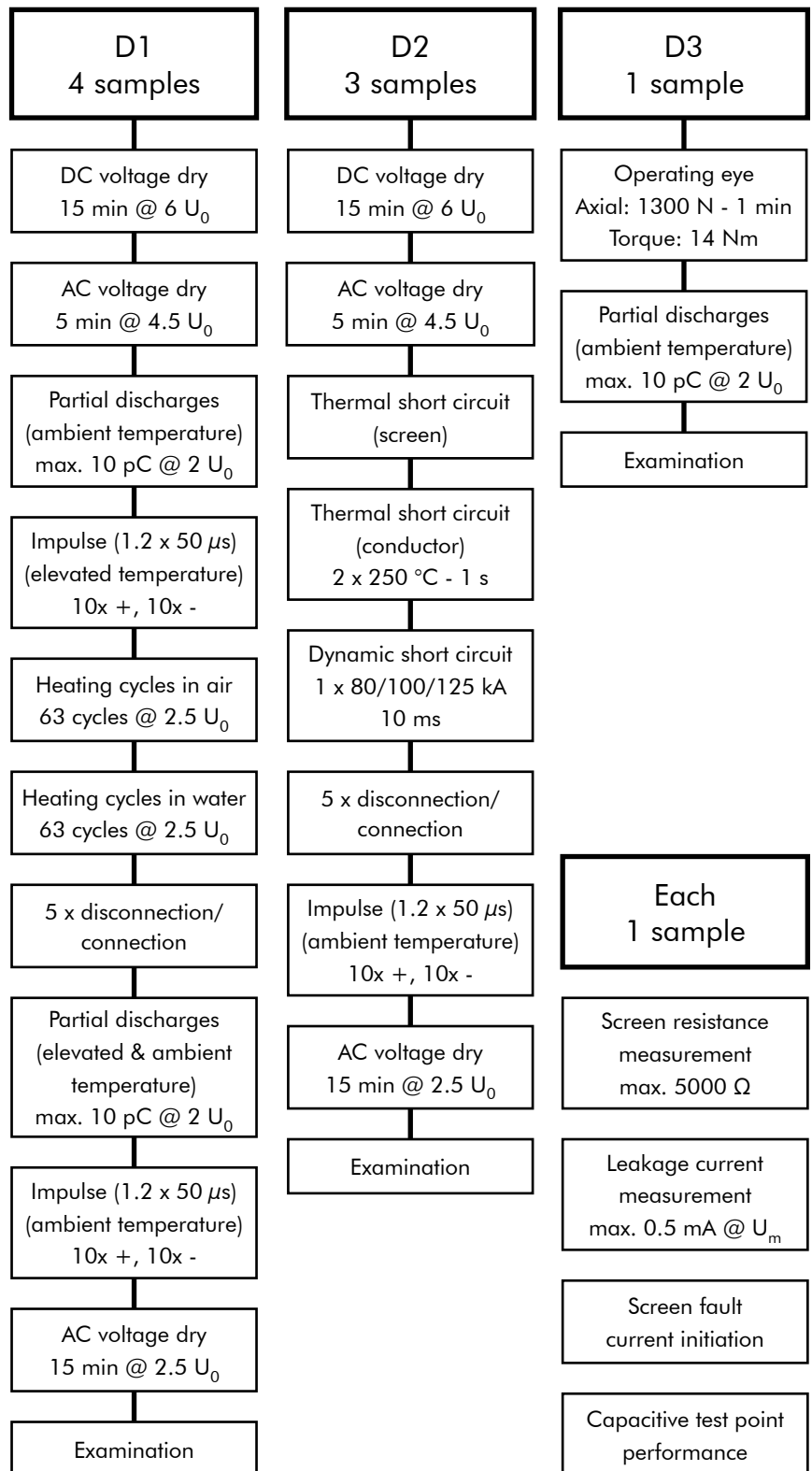

JUMPERS AND TEST LEADS

APPLICATION

Jumpers are prefabricated lengths of cable on which separable connectors or terminations are installed on each end. Jumpers are used as fixed solutions in windturbines, transformers,... Test leads are typically used to perform tests on electrical installations, transformers, motors...

DESIGN

Jumpers comprise:

1. Connector or termination adapted to the chosen interface type and chosen voltage class.
2. Cable length.
3. A screen wire finishing with an earthing lug is standard. Other finishings are available upon request.

All Jumpers are standard tested for AC withstand and partial discharge before leaving the factory. Other tests can be done on request.



6/10 (12) kV
6.35/11 (12) kV
8.7/15 (17.5) kV
12/20 (24) kV
12.7/22 (24) kV
18/30 (36) kV
19/33 (36) kV
20.8/36 (42) kV
26/45 (52) kV

Up to 52 kV

EUROMOLD®

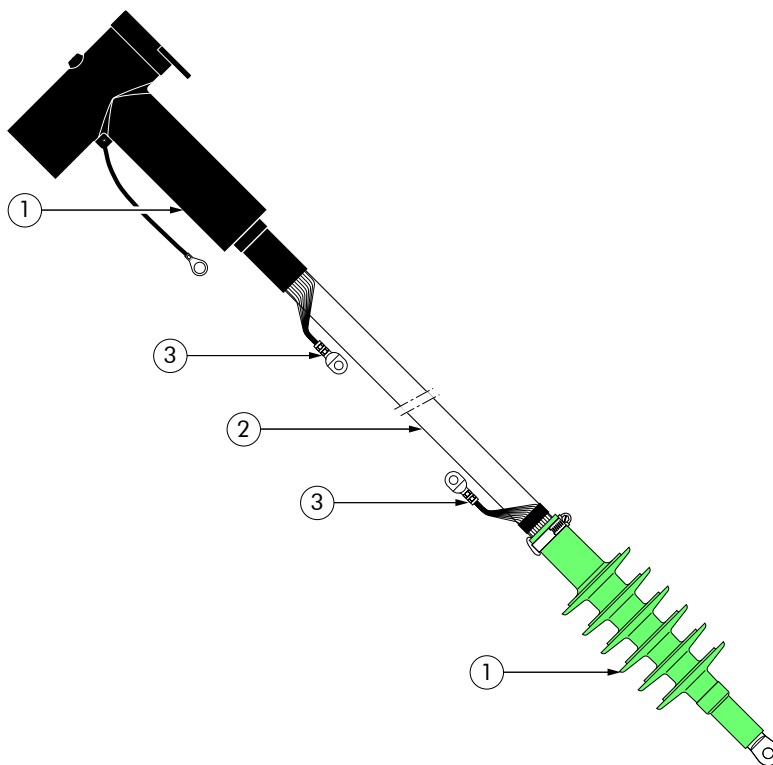

09/2017

ENQUIRY SHEET

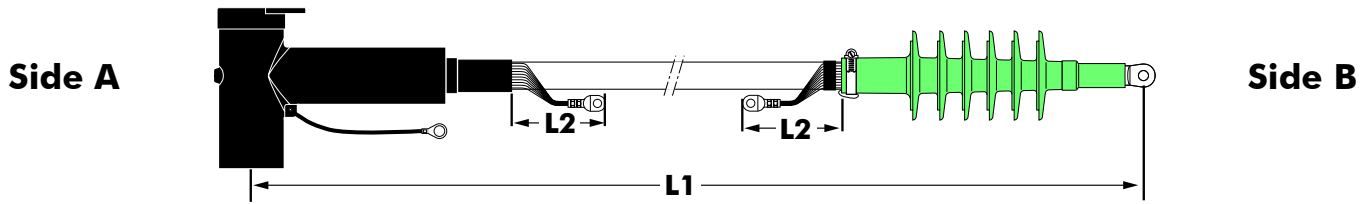

1. Product to be installed on side A: 430TB 480TB 484TB Other:.....

2. Product to be installed on side B: 480TB AFN AIN Other:.....

3. Voltage class:...../.....(.....) kV **Current:**..... A

4. Length cable lead (L1):.....

Cable type: XLPE EPR Other:.....

5. Screen: Length given by product..... Length L2:.....

Braided

Extra cable

Twisted

Joint contact+grounding cable

Other

Joint contact+grounding cable+HS tube

6. Position contact surface side B: In line with side A 90° angle with side A

Other:.....

7. Testing: AC PD Impulse Test report

8. Packaging: Cardboard box Wooden box

9. Remarks:

.....

.....

.....

.....

.....

REFERENCES

ABOUT NEXANS

Nexans brings energy to life through an extensive range of cables and cabling solutions that deliver increased performance for our customers worldwide. Nexans' teams are committed to a partnership approach that supports customers in four main business areas: Power transmission and distribution (submarine and land), Energy resources (Oil & Gas, Mining and Renewables), Transportation (Road, Rail, Air, Sea) and Building (Commercial, Residential and Data Centers). Nexans' strategy

ABOUT NEXANS POWER ACCESSORIES

Nexans, and its trademarks EUROMOLD® and GPH®, is a worldwide presence in power accessories. The power accessories business group employs 1000 people in 18 countries and has sales in over 90 countries. With more than 50 years of experience in cable accessories it is considered the leading European designer and manufacturer of power accessories.

is founded on continuous innovation in products, solutions and services, employee development, customer training and the introduction of safe, low-environmental-impact industrial processes.

In 2013, Nexans became the first cable player to create a Foundation to introduce sustained initiatives for access to energy for disadvantaged communities worldwide.

Nexans is an active member of Europacable, the European Association of Wire & Cable Manufacturers, and a signatory of

the Europacable Industry Charter. The Charter expresses its members' commitment to the principles and objectives of developing ethical, sustainable and high-quality cables.

Nexans, acting for the energy transition, has an industrial presence in 40 countries, commercial activities worldwide, is employing close to 26,000 people and generating sales in 2016 of 5.8 billion euros. Nexans is listed on NYSE Euronext Paris, compartment A.

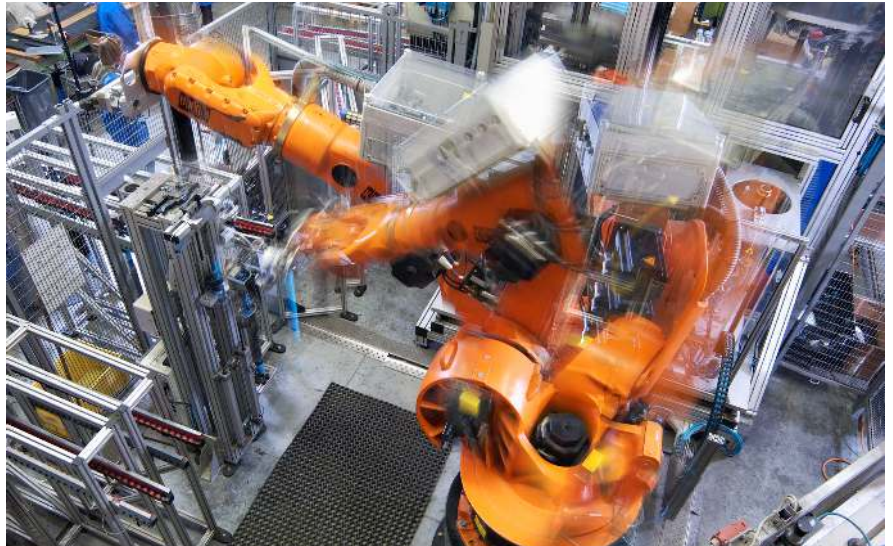

POWER NETWORKS

Nexans contributes to the reliability and security of energy networks around the world by increasing capacity and reducing technical and non-technical losses through affordable, state-of-the-art technology.

Some of our main clients in this sector are EDF, RWE, Endessa, E-on, Iberdrola, ENEL, BKW Bern.

09/2017

WIND TURBINES AND WIND FARMS

Nexans is, with its GPH®, EUROMOLD® and Windlink product lines, an important partner in wind energy projects. In Germany we supply thousands of connectors and sleeves to the leading OEMs in wind turbines and power utility applications. Prefabricated jumpers -pretested in the factory to assure immediate and fault-free installation- have been supplied to GE Wind, Vestas and others.



RAILWAY NETWORKS AND ROLLING STOCK

Since many years Nexans has been a reliable partner for railway networks and rolling stock producers. Our products have been used in large projects like the Lötsch tunnel in Switzerland or the Transrapid project in Shanghai and in many other projects since the early 1970s.

OIL AND GAS

Nexans has been supplying connectors and joints for oil and gas projects (offshore and onshore) since more than 30 years. Some examples are listed below:

- Amec/Snepco Bonga Project, Nigeria
- Shell Tern Alpha, North Sea
- FPSO (Floating Production Storage and Offloading) Serpentina
- FPSO Anasuria
- FPSO Terra Nova, Canada
- FPSO Schielgallion
- Aker Kvaerner Oil & Gas, Celdonia Project
- AIOC (Azerbaijan International Operating Consortium), Full Field Development Project Azerbaijan
- Buzzard Field, North Sea
- BP ACG project Azerbaijan

- BP Shaz Deniz, Caspian Sea -
- Shell Sakhalin Island, Sea of Japan -
- Petronas, Malaysia.

OTHER INDUSTRIES

From motors to mines, from pumps to ships, all have been powered through Nexans, EUROMOLD® and GPH® accessories since the 1950s.



ENQUIRY SHEET

Nexans Network Solutions N.V.
Div. Euromold

Zuid III - Industrielaan 12
 B-9320 EREMBODEGEM - AALST - BELGIUM

Tel.: +32 (0)53 850 220
 E-Mail: sales.euromold@nexans.com

Your company details:

Company:.....
 Address:.....

 Tel.:.....
 E-Mail:.....

CABLE DATA

Cable manufacturer: / **Cable identification:**

- Cable type:** Single core Three core
- System voltage (kV):** 3.6/6 (7.2) 12/20 (24) 20.8/36 (42)
- 6/10 (12) 12.7/22 (24) Other: / (.....)
- 6.35/11 (12) 18/30 (36)
- 8.7/15 (17.5) 19/33 (36)
- System current (A):** 250 630 1250
- 400 800 Other: A

Single core

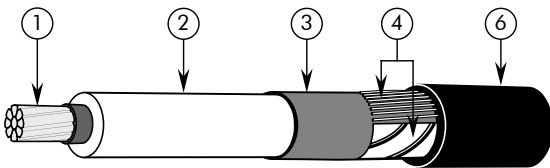

Three core

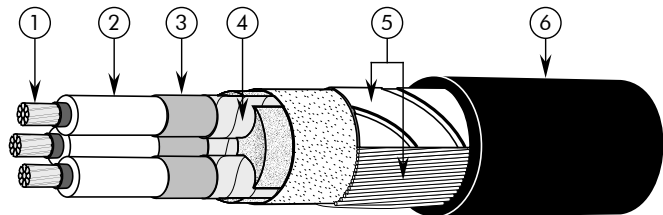

Cable description:

- ① Conductor material: Al Cu
- Round Sector shaped Solid Stranded Class 5
- Conductor size: mm² (16 - 25 - 35 - 50 - 70 - 95 - 120 - 150 - 185 - 240 - 300 - 400 - 500 - 630 - 800 - 1000 mm²)
- ② Core insulation: - type: XLPE EPR Paper
- diameter: mm
- ③ Semi-conductive screen: - type: Bonded Easy strip Fabric tape
- diameter (Optional): mm
- ④ Metal screen type: Al Cu Wire screen Tape screen
- ⑤ Armour type: No SWA STA
- ⑥ Outer sheath: XLPE PVC Other Diameter:.....mm

Bushing type (If applicable):



THORNE &
DERRICK
INTERNATIONAL

Thorne & Derrick

+44 (0) 191 410 4292

www.powerandcables.com



Find out more about Nexans Power Accessories.

09/2017

BRINGS ENERGY TO LIFE