

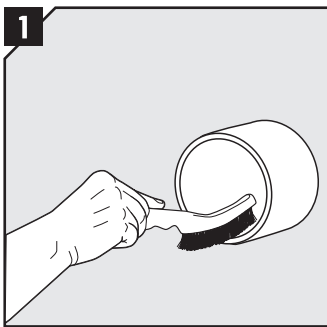

**Installation Roxtec RS 25-200**

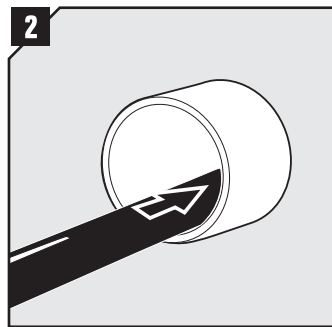

Remove any dirt in the sleeve/hole.



Pull the cable/pipe through. Please see note and table for aperture dimensions.

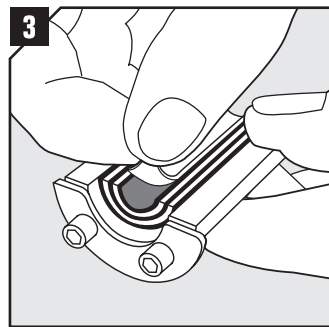

Adapt the seal to the cable/pipe by peeling off layers from the halves until you reach the gap seen in pic.4. The halves may not differ by more than one layer.

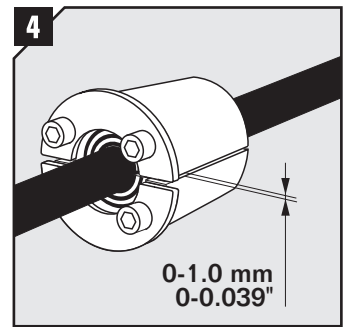

0-1.0 mm  
0-0.039"

Try to achieve a 0-1.0 mm gap between the two halves when held against the cable/pipe.

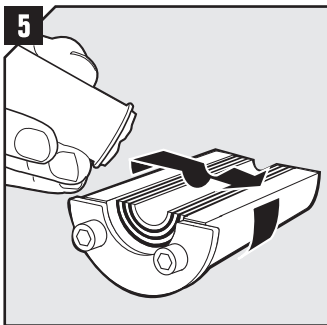

Lubricate thoroughly on the inside surfaces and sparsely on the outside of the seal with Roxtec Lubricant.

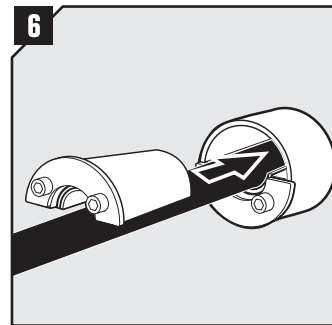

Insert the halves into the sleeve.

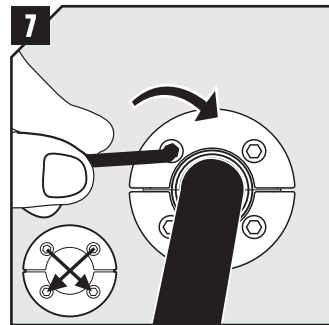

Tighten the screws crosswise. The seal will compress and seal the transit. Please see table for recommended max torque.

**Aperture dimensions**

Type:	Aperture Ø (mm)	Clearance depth (mm)
RS 25	25-26	45
RS 31	31-32	45
RS 43	43-45	83
RS 50	50-52	83
RS 68	68-70	83
RS 75	75-77	83
RS 100	100-102	83
RS 125	125-127	83
RS 150	150-152	83
RS 175	175-177	83
RS 200	200-203	83

**Recommended torque**

Size: RS	Rec. torque* (Nm)
25 - 31	1
43 - 100	4
125 - 200	7

\* The recommended torque depends on several things, e.g cable or pipe size, amount of used lubricant, sleeve size or material in the cable sheath.

## Installation Roxtec RS 225-644

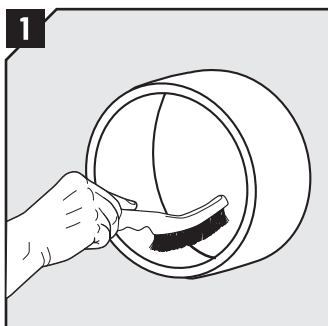

Remove any dirt in the sleeve/hole.

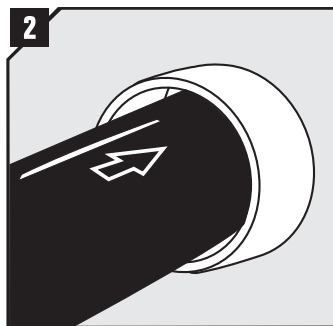

Pull the cable/pipe through. Please see note and table for aperture dimensions.

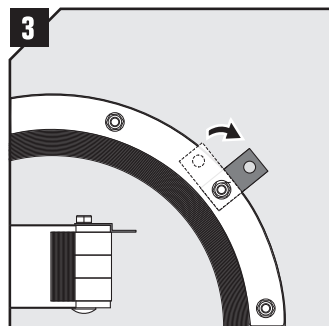

Fold out all stop flanges. Make sure that they are secured by the fittings.

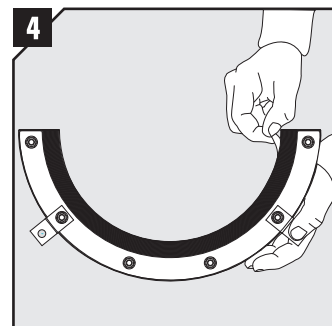

Adapt the seal to the cable/pipe by peeling off layers from the halves until you reach the gap seen in pic.5. The halves may not differ by more than one layer.

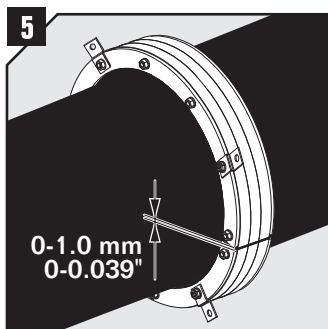

Try to achieve a 0-1.0 mm gap between the two halves when held against the cable/pipe.

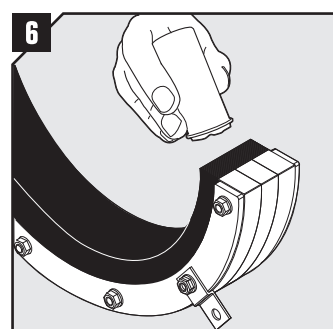

Lubricate thoroughly on the inside surfaces and sparsely on the outside of the seal with Roxtec Lubricant.

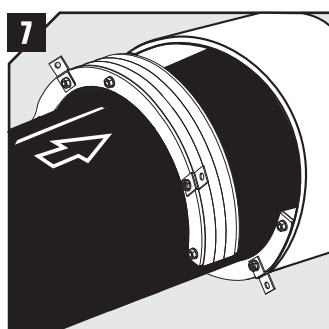

Insert the halves into the sleeve.

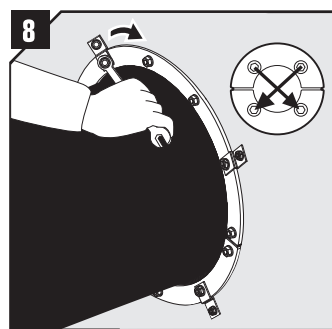

Tighten the bolts crosswise. The seal will compress and seal the transit. Please see table for recommended max torque.

### Aperture dimensions

Type:	Aperture Ø (mm)	Clearance depth (mm)	Type:	Aperture Ø (mm)	Clearance depth (mm)
RS 225	225-228	75	RS 450	450-453	75
RS 250	250-253	75	RS 500	500-503	75
RS 300	300-303	75	RS 550	550-553	75
RS 350	350-353	75	RS 600	600-603	75
RS 400	400-403	75	RS 644	644-647	75

### Recommended torque

Size:	Rec. torque* (Nm)
RS	
225 - 400	17
450 - 644	35

\* The recommended torque depends on several things, e.g cable or pipe size, amount of used lubricant, sleeve size or material in the cable sheath.

### Disassembly

Reverse order

### Note

- Cable/pipe shall be routed perpendicularly to the sleeve or hole.
- Cable/pipe of considerable weight must be supported by surrounding structure or equipment to prevent damage or subsidence to the seal.
- For optimum reliability, wait 24 hours or longer after installation before exposing the cables/pipes to strain or pressure.



**THORNE & DERRICK**  
INTERNATIONAL

**Thorne & Derrick**  
+44 (0) 191 410 4292  
www.powerandcables.com

### DISCLAIMER

"The Roxtec cable entry sealing system ("the Roxtec system") is a modular-based system of sealing products consisting of different components. Each and every one of the components is necessary for the best performance of the Roxtec system. The Roxtec system has been certified to resist a number of different hazards. Any such certification, and the ability of the Roxtec system to resist such hazards, is dependent on all components that are installed as a part of the Roxtec system. Thus, the certification is not valid and does not apply unless all components installed as part of the Roxtec system are manufactured by or under license from Roxtec ("authorized manufacturer"). Roxtec gives no performance guarantee with respect to the Roxtec system, unless (i) all components installed as part of the Roxtec system are manufactured by an authorized manufacturer and (ii) the purchaser is in compliance with (a), and (b), below.

(a) During storage, the Roxtec system or part thereof, shall be kept indoors in its original packaging at room temperature.

(b) Installation shall be carried out in accordance with Roxtec installation instructions in effect from time to time.

The product information provided by Roxtec does not release the purchaser of the Roxtec system, or part thereof, from the obligation to independently determine the suitability of the products for the intended process, installation and/or use.

Roxtec gives no guarantee for the Roxtec system or any part thereof and assumes no liability for any loss or damage whatsoever, whether direct, indirect, consequential, loss of profit or otherwise, occurred or caused by the Roxtec systems or installations containing components not manufactured by an authorized manufacturer.

Roxtec expressly excludes any implied warranties of merchantability and fitness for a particular purpose and all other express or implied representations and warranties provided by statute or common law. User determines suitability of the Roxtec system for intended use and assumes all risk and liability in connection therewith. In no event shall Roxtec be liable for consequential, punitive, special, exemplary or incidental damages."

