

Insulation Products



THORNE &
DERRICK
INTERNATIONAL

Thorne & Derrick

+44 (0) 191 410 4292

www.powerandcables.com

Cable Repair Sleeve RMS

For rapid and secure cable repair on site.

HellermannTyton

Heat Shrinkable Cable Repair Sleeves



RMS wrap-around sleeves for rapid and secure cable repair on site.



RMS kit contains: Repair sleeve, steel closure, abrasive strip, cleaning sachet and instruction sheet.

• **RMS**

RMS are heat shrinkable wrap-around sleeves used in cable repair and splicing applications. The wrap around sleeves are a fast, labour saving and permanent cable repair and sealing system. The sleeve is simply wrapped around the cable and held in place using a rail and channel closure. RMS is especially useful for repair of long and buried cables where it would be difficult or impossible to use a shrink tubing. Heating by a torch will shrink the sleeve and melt the adhesive inner coating resulting in a moisture-proof, insulating and tight-fitting repair. The sleeve provides excellent corrosion protection, abrasion and weather resistance making it also ideal for LV cable joint outer protection. The high shrink ratio limits the number of sizes to only 6. Each size covers a range of cable sizes. RMS is available in various standard lengths. Other lengths available on factory request.

Features and Benefits

- Fast, moisture proof and permanent repair of cable jackets
- Only 6 sizes for a wide range of cable diameters: from 10 mm up to 160 mm
- Available in 4 standard lengths and also available in custom lengths.
- Each RMS kit is ready for use and comes with instruction sheet, abrasive strip and cleaning sachet.
- Weather resistant and halogen free
- TCP (thermo chromatic paint) spots indicate the sleeve has been sufficiently heated

Material Data	
Material	Polyolefin, chemically cross linked (POX)
Colour	Black (BK)
Shrink Ratio	up to 4,5:1
Operating Temperature	-40 °C to +120 °C
Min. Shrink Temperature	+110 °C
Softening Point	+105 °C
Adhesive	
Dielectric Strength	12 kV/mm

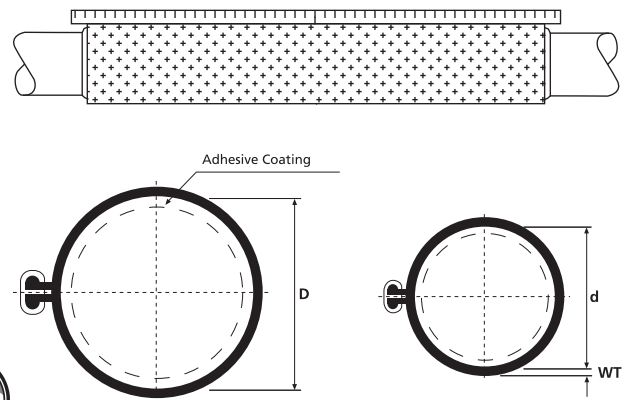

Technical Table						
Article-No.	Type	Supplied Ø D min.	Recov. Ø d max.	Wall (WT) nom.	Cable Ø	Length (L)
450-20000	RMS 43-10	43	10	2.30	15 - 35	250
450-20001	RMS 43-10	43	10	2.30	15 - 35	500
450-20004	RMS 43-10	43	10	2.30	15 - 35	750
450-20002	RMS 43-10	43	10	2.30	15 - 35	1000
450-20010	RMS 52-15	52	15	2.30	20 - 45	250
450-20011	RMS 52-15	52	15	2.30	20 - 45	500
450-20014	RMS 52-15	52	15	2.30	20 - 45	750
450-20012	RMS 52-15	52	15	2.30	20 - 45	1000
450-20021	RMS 76-22	76	22	2.50	28 - 65	500
450-20024	RMS 76-22	76	22	2.50	28 - 65	750
450-20022	RMS 76-22	76	22	2.50	28 - 65	1000
450-20030	RMS 100-30	100	30	2.54	35 - 85	500
450-20031	RMS 100-30	100	30	2.54	35 - 85	1000
450-20041	RMS 139-38	139	38	2.77	45 - 120	1000
450-20050	RMS 185-55	185	55	2.74	65 - 160	1000

All dimensions in mm. Subject to technical changes. Other non standard sizes and length available on request.

Heat Shrinkable Cable Repair Sleeves

• RMS

Application Method

RMS sleeves are wrapped around the cable and closed with a steel channel. The inside of the sleeve is adhesive lined and will effectively seal the cable after shrinkage. RMS sleeves provide fast, watertight and reliable insulation.

To select the right sleeve size, see application range table. Choose sleeve length so that cable next to damaged area is covered by at least 40 mm of sleeve length.



www.HellermannTyton.co.uk/rms

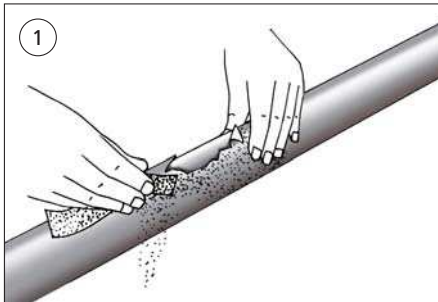

For good sealing roughen cable jacket with abrasive cloth strip.

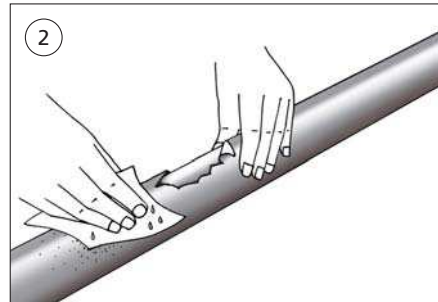

Degrease and clean cable jacket with tissue in cleaning sachet.

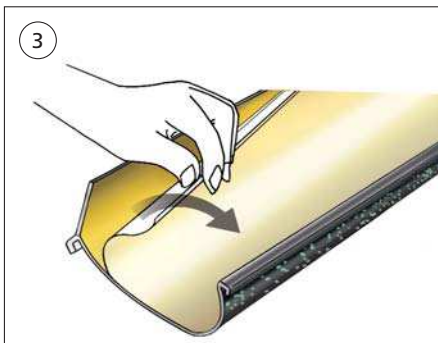

Remove protective foil from adhesive layer on the inside of the sleeve.

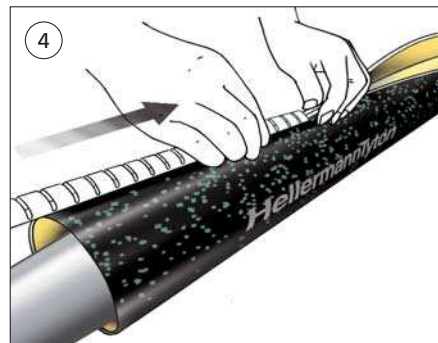

Wrap sleeve around the cable. Install the steel closure channel over the raised profiles of the sleeve and center the sleeve over the damaged area.

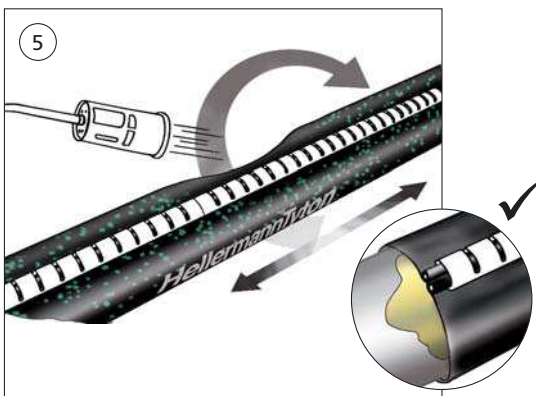

Use yellow flame tip of a suitable propane torch. Start heating the metal channel area first for about half a minute. Then start shrinking sleeve at the center working the flame around all sides to apply uniform heat.

Keep flame moving to avoid scorching. After center part has shrunk work torch to one end of sleeve then to the opposite end.



To determine if the sleeve has fully recovered, especially on the back and underside of the sleeve, check if all TCP spots have disappeared and adhesive has flowed from both ends.



For further information please contact:

HellermannTyton



**THORNE &
DERRICK
INTERNATIONAL**

Thorne & Derrick
+44 (0) 191 410 4292
www.powerandcables.com