

FILO form

MDII

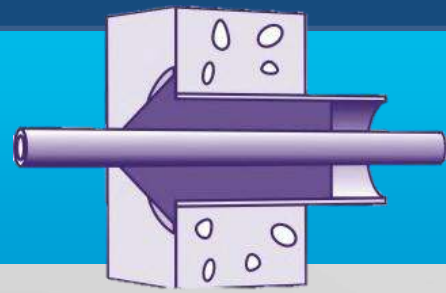

Filoform duct sealing systems have been developed to provide an effective gas and watertight seal of underground cable penetrations.

When installing our duct sealing system MDII, you will protect valuables from damage which is caused by gas and water leaks.



THORNE &
DERRICK
INTERNATIONAL

Thorne & Derrick
+44 (0) 191 410 4292
www.powerandcables.com



Filoform duct seals type MD are based on a specially formulated two-component expanding polyurethane resin. The polyurethane sealant is packed in a transparent plastic bag with a screw ring. In this plastic bag, the two components are separated by a clamping profile. After removal of the clamping profile, the two components are simply mixed together for 30 seconds.

The package is now ready for use and can be easily opened with the use of the screw nipple. After pouring the resin in the duct, the resin starts expanding by forming CO². During the expansion the polyurethane filling material penetrates all areas inside the duct, thus sealing all openings regardless of the shape of the duct or borehole. After this the hardening process starts.

The Filoform two component filler provides not only a 100% gas and watertight seal but also offers excellent mechanical strength.

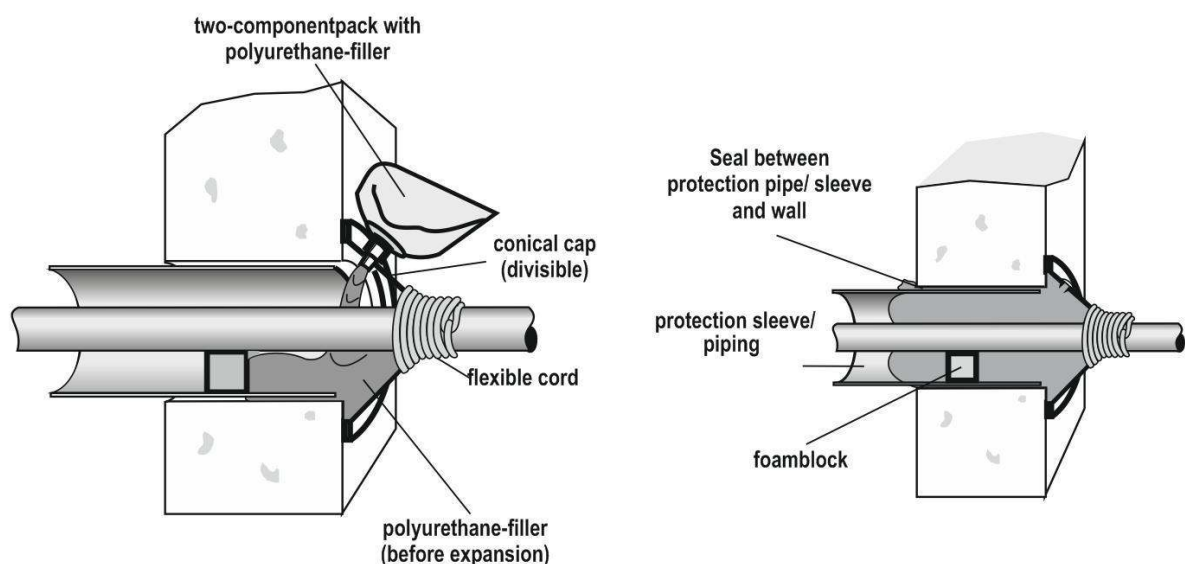

connect ► seal ► protect ►

Duct sealing system type MDII has been developed to provide an effective and simple solution to all gas- and watertight duct sealing requirements. MDII will not only seal the space between the cable or pipe but also the space between the duct and the wall in one operation.

The MDII system is suitable in situations where more than one cable or pipe is in the duct. The opening of the duct does not need to be completely round.

Seals all known materials: PVC & PE sheeted cables, PILC cables, (HD)PE pipes, PE drinking water conduits.

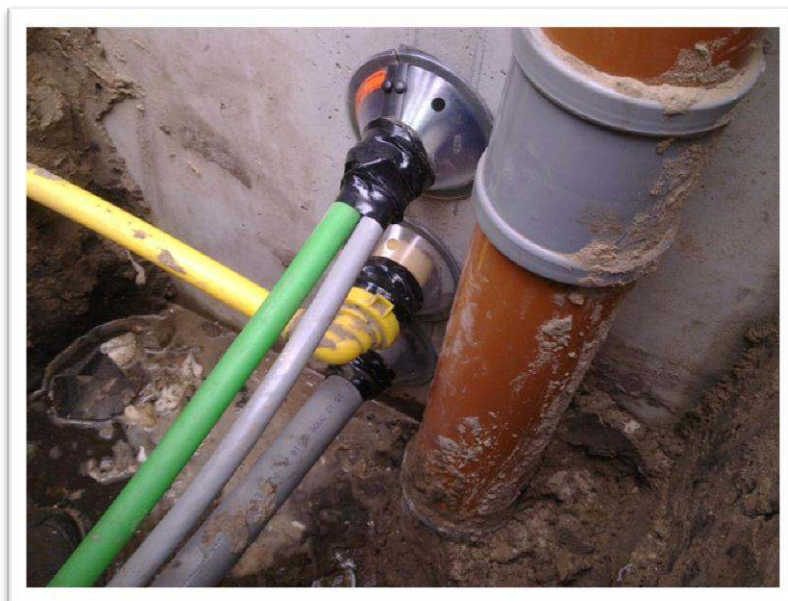

connect ▶ seal ▶ protect ▶

Dimensions

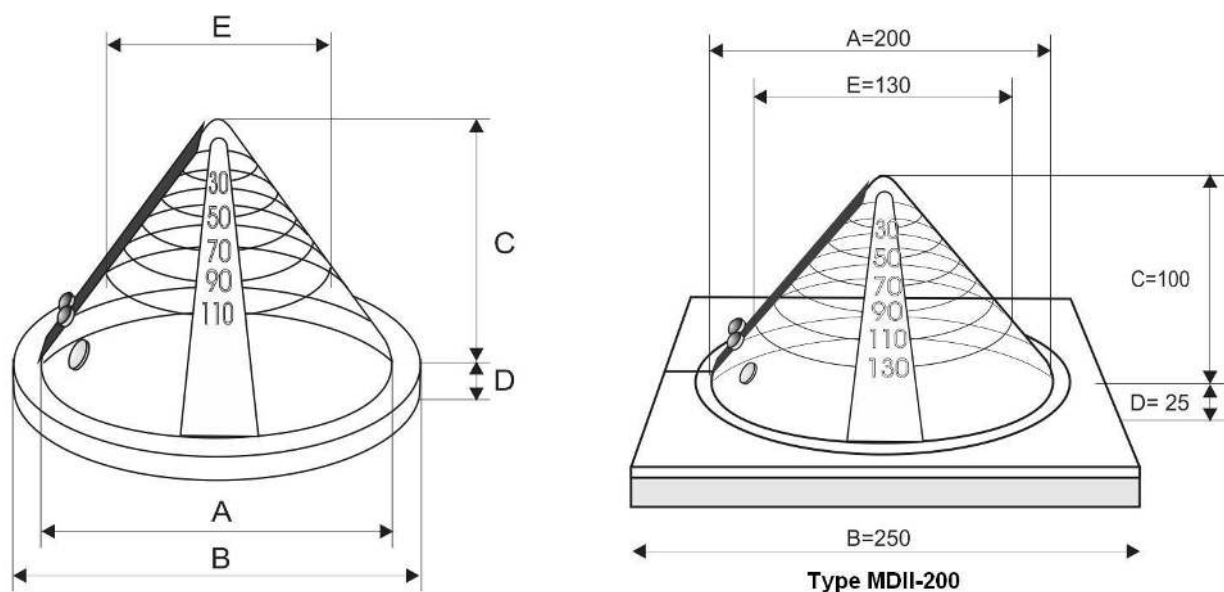

	MDII-50	MDII-110	MDII-125	MDII-160	MDII-200
A	80	130	150	200	200
B	100	150	170	220	250
C	80	75	70	90	160
D	16	15	15	15	25
E	40	70	90	130	160

Due to the design of the divisible conical cap, it is possible to install the system also in existing situations. Installation of the cap can be done by trimming the cap to the desired diameter of the cable or pipe.

connect ► seal ► protect ►

Product overview

Part Number	Description	Maximum duct diameter (mm)	Maximum cable / pipe diameter in the duct (mm)
280271	MDII-50 duct sealing kit	max. Ø 50	max. Ø 40
280261	MDII-110 duct sealing kit	max. Ø 110	max. Ø 70
280251	MDII-125 duct sealing kit	max. Ø 125	max. Ø 90
280241	MDII-160 duct sealing kit	max. Ø 160	max. Ø 130
280246	MDII-200 duct sealing kit	max. Ø 200	max. Ø 160



Set contents

- ▶ Conical cap with sealing cap
- ▶ Foam support block
- ▶ Self-adhesive foam strip
- ▶ Flexible cord
- ▶ Expanding polyurethane filler
- ▶ Screw nipple
- ▶ Set protective gloves
- ▶ Sandpaper
- ▶ Installation instructions

connect ▶ seal ▶ protect ▶

Specifications

Properties	Unit	Value
Start time expansion	seconds	> 95
End time expansion	minutes	15
Compressive strength	N / cm ²	> 100
Gas and water tightness 1,0bar	30 days	no leakage
Density 10m water column	30 days	no leakage
Volume consistency	cube 10 x 10cm	no change
temperature Cycles, -20°C tot +40°C	10 consecutive cycles	no leakage
Vibration test 10 Hz/amplitude 3mm	240 hours	no leakage
axial tensile force	diameter x 10 N	no leakage
Resistance to bending	cables 45° in 2 directions >250mm	no leakage
Expansion polyurethane foam in pipe	cm	< 40
Chemical resistance		
0,1N Na ₂ SO ₄	30 days	no degradation
0,1N NaCl	30 days	no degradation
0,1N H ₂ SO ₄	30 days	no degradation
0,1N NaOH	30 days	no degradation
Diesel	30 days	no degradation
Gasonline	30 days	no degradation
Resistance		
Molds		good
Rodents		good
Shelf life	months	minimal 18

Installation video



<http://vimeo.com/39628396>



**THORNE &
DERRICK**
INTERNATIONAL

Thorne & Derrick
+44 (0) 191 410 4292
www.powerandcables.com