

Operating temperature range -60°C +80°C

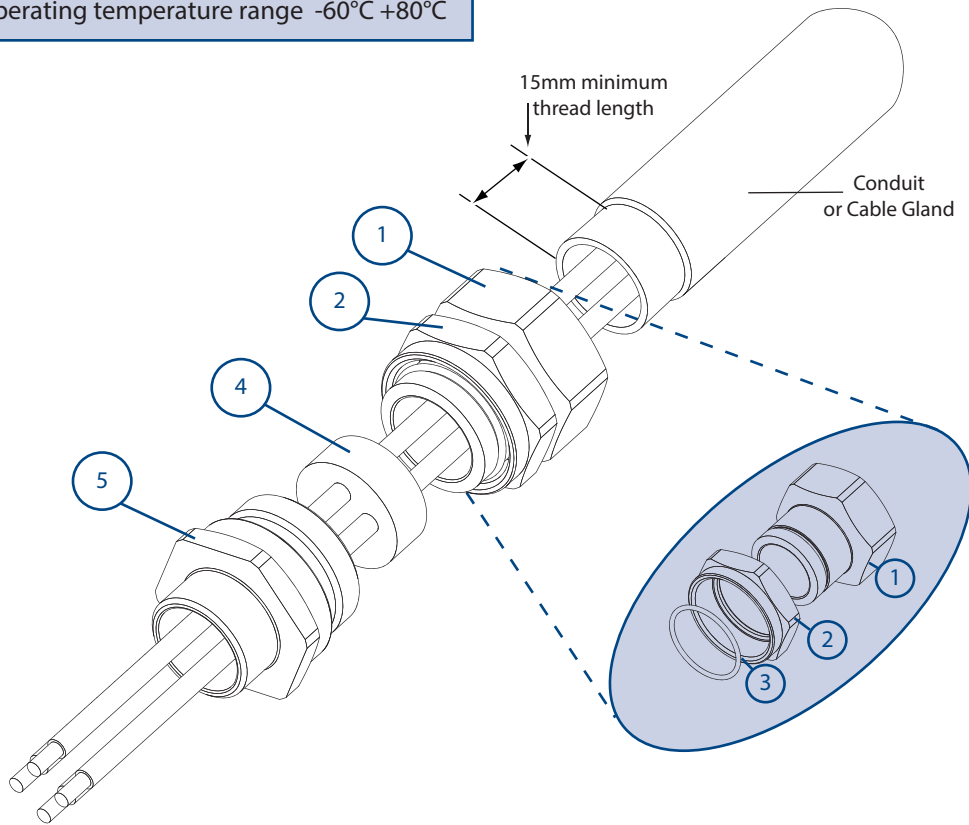

### Certification Details

Gland Type: SB 474  
 Exdb IIC Gb, Exeb II Gb, Extb IIIC Db  
 Baseefa06ATEX0056X (Ex) II 2 GD IP66 CE  
 IECEx BAS06.0013X  
 IEx 14.0272X  
 EAC TC RU C-GB.ГБ05.В.00750  
 CNEEx 12.3449X

- 1. Backnut
  - 2. Running Coupler
  - 3. Spring Clip
  - 4. Seal
  - 5. Entry
- } Sub-Assembly

**IMPORTANT:** Prior to installation, it may be necessary to release conduit from its clamping mechanism to allow sufficient movement.

### Cable Preparation

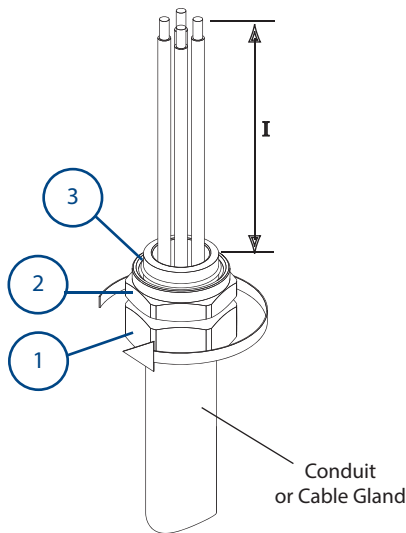

**A**  
 Pull sufficient length 'I' of cable through conduit/cable gland to suit equipment.  
 Screw backnut ① on to pre-threaded conduit/cable gland and tighten with spanner/wrench.

### Gland Preparation

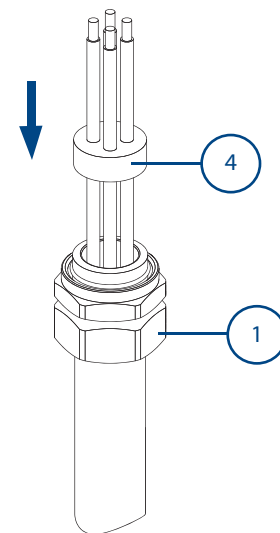

**B**  
 Select the correct punch tool to suit conductor sizes (see table) and punch out the required number of holes in the seal using the indented positions as a guide. Pass the individual conductors through the appropriately sized punched holes in the seal ④ ensuring they are not twisted or kinked and slide down to backnut ①.

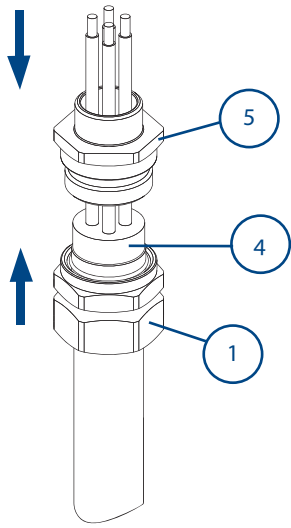

**C**  
Pass the conductors through the entry ⑤ which may have previously been fitted into the equipment. Locate seal ④ in the counter bore of the entry ⑤ by bringing the conduit/cable gland towards the equipment.

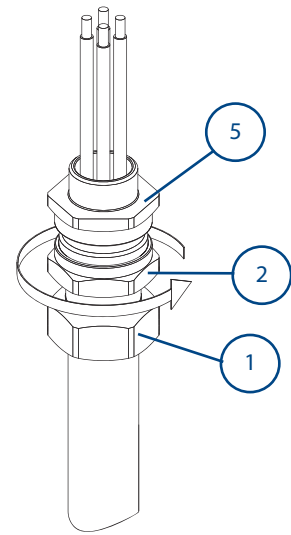

**D**  
Locate the running coupler ② onto the entry ⑤ and hand tighten until resistance is felt against the seal. Then using a spanner/wrench tighten the running coupler ② onto the entry ⑤ a minimum of one full turn, ensuring that entry ⑤ is prevented from turning and the backnut ① remains tight on the conduit/cable gland.

**SCHEDULE OF LIMITATIONS:**

1. These cable gland types are only suitable for use with fixed apparatus, the cable for which must be effectively clamped and cleated elsewhere.
2. This cable gland has an operating temperature range of -60°C to +80°C.
3. A seal must be formed between the equipment and the cable gland to maintain the appropriate degree of protection against ingress of dust, solid objects and water.

**ACCESSORIES:**

Before cable gland assembly or stripping of the cable gland assembly, consideration should be given to any cable gland accessories that may be required, such as: -

- Shroud, to offer additional corrosion protection.
- Locknut, to secure cable glands into position.
- Sealing washer, to offer additional ingress protection of the enclosure at the cable gland entry.
- Earhtag, to provide an external armour/braid bonding point
- Serrated washer, to dampen any vibrations that may loosen the locknut or cable gland assembly.

CABLE GLAND SELECTION TABLE								
Size Ref.	Male Entry Thread Size		Female Entry Thread Size		Compressed Length	Maximum Length	Hexagon Dimensions	
	Metric	NPT	Metric	NPT			Across Flats	Across Corners
A	M20	#	M20	½" - ¾"	56.4	69	30.0	32.5
B	M25	#	M25	¾" - 1"	48.2	61	36.0	39.5
C	M32	#	M32	1" - 1¼"	61.6	77	46.0	50.5

# Thread sizes specified with order

CABLE GLAND SIZE FOR CONDUCTOR					
Maximum No. of Cores	Cores Cross Sectional Area mm <sup>2</sup>				
	1.5	2.5	4.0	6.0	10.0
7	A & B	A & B	B & C	C	C
4	-	-	-	B	-
3	-	-	-	-	B

PUNCH TOOL SIZE DETAILS			
Punch Ref.	No.1	No.2	No.3
Core C.S.A. mm <sup>2</sup>	1.5 - 2.5	4.0 - 6.0	10.0

**EU Declaration of Conformity in accordance with European Directive 2014/34/EU**  
**Manufacturer: Hawke International**  
**Address: Oxford Street West, Ashton-under-Lyne, OL7 0NA, United Kingdom.**

**Equipment: Group II Compression Cable Glands Type: SB 474**

**Provisions of the Directive fulfilled by the Equipment:** Group II Category 2GD Exeb IIC Gb, Exdb IIC Gb, Extb IIIC Db – IP66

**Notified Body for EU-Type Examination:** SGS-Baseefa 1180 Buxton UK

**EU-type Examination Certificate:** Baseefa06ATEX0056X

**Notified Body for production:** SGS-Baseefa 1180 Buxton UK

**Harmonised Standards used:** EN 60079-0:2012+A11:2013, EN60079-1:2014, EN60079-7:2015, EN60079-31:2014

**On behalf of the above named company, I declare that, on the date the equipment accompanied by this declaration is placed on the market, the equipment conforms with all technical and regulatory requirements of the above listed directives.**

  
 .....  
**A. Tindall**  
**Technical Manager**



**Thorne & Derrick**  
 +44 (0) 191 410 4292  
 www.powerandcables.com