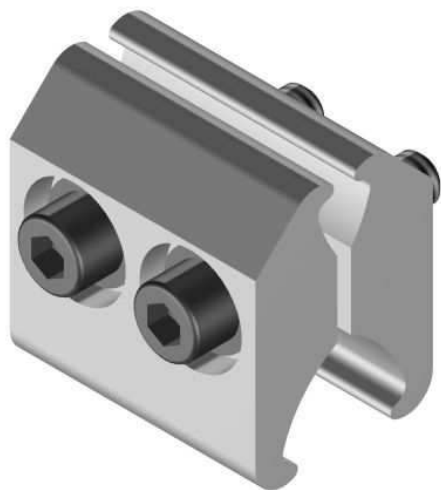

**BST/U Connector****BST/U(H) Connector****Principle Application:**

Branch connections from solid sector shaped aluminium conductors.

**Range:**

Branch Conductor (mm <sup>2</sup> )	Mains conductor (mm <sup>2</sup> )			
	150	185	240	300
70	BST/U & (H)	BST/U & (H)	BST/U & (H)	BST/U & (H)
95	-	BST/U & (H)	BST/U & (H)	BST/U & (H)
120	-	BST/U & (H)	BST/U & (H)	BST/U & (H)
150	-	-	BST/U & (H)	BST/U & (H)
185	-	-	BST/U & (H)	BST/U & (H)
240	-	-	-	BST/U & (H)

The Hepworth 'BST/U' and 'BST/U(H)' connectors has been designed to accommodate three or four core sector shaped solid aluminium conductors of dissimilar sizes, within the ranges specified above. It should be noted, however, that these combinations are specified for the same sector shape, e.g. three core to three core. Should combinations of three and four core be required, it is suggested that verification of their suitability be obtained before use.

Each connector is supplied in a sealed polythene bag, and details of fitting procedures are included in the technical data overleaf.

NOTE: If required the **BST/U** connector can also be supplied with 13mm A/F hexagon head set screws, **Product code BST/U(H)**.

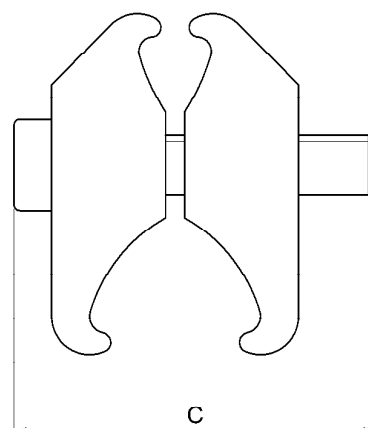
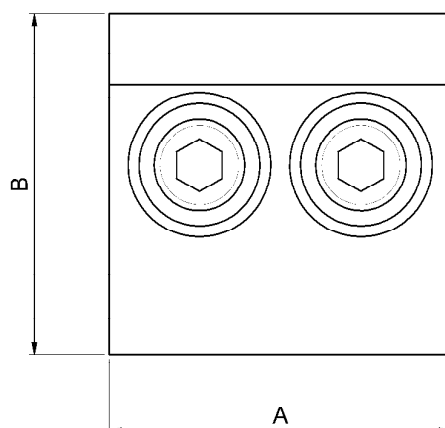
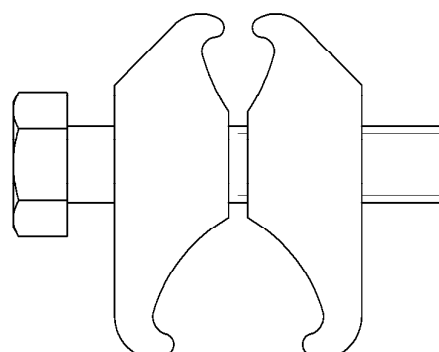
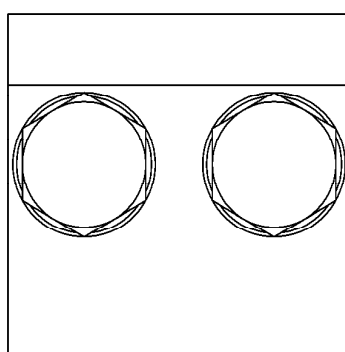
**BST/U  
Connector****Physical  
Dimensions****BST/U(H)  
Connector****Physical  
Dimensions**

Connector Reference	Dimensions (mm)		
	A	B	C
BST/U	36	35.5	38.5
BST/U(H)	36	35.5	45.5

**Material:** Aluminium Alloy

**Fitting Instructions:**

Strip the insulation from the mains core at the required position using the length of the connectors as a guide, and thoroughly abrade the exposed conductor. Set the branch conductor to achieve a curve-to-curve configuration and cut to length, then strip the insulation to match the main and abrade the exposed conductor. Loosely fit the connector, ensuring that the conductors are correctly aligned before fully tightening the socket head screws using a 3/16" A/F hexagonal drive.

**NOTE:** It may be found that with smaller branch cables the connector can accept the conductor with the apex facing inwards toward the main, but it is generally recommended that the conductors are set curve-to-curve to avoid any possible interference with the threads of the clamp screws.