

'ML20/x-x' Aluminium Mechanical Termination with Moisture/Contaminant Block For Low/Medium Voltage Applications

## MECHANICAL CONNECTORS

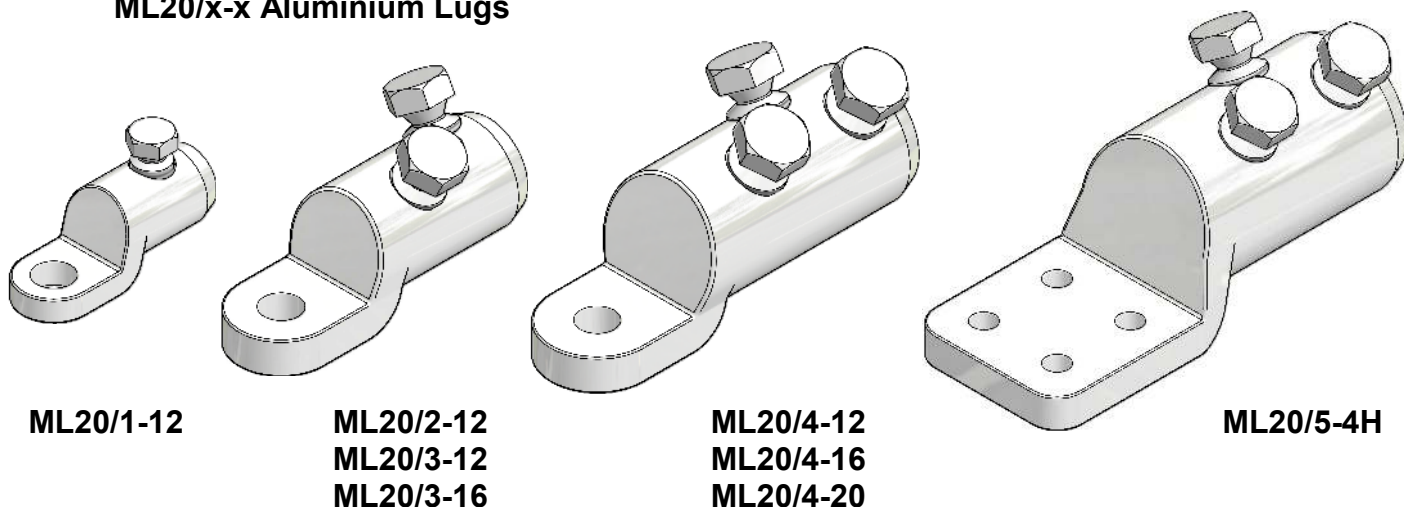

### ML20/x-x Aluminium Lugs



**ML20/1-12**

**ML20/2-12  
ML20/3-12  
ML20/3-16**

**ML20/4-12  
ML20/4-16  
ML20/4-20**

**ML20/5-4H**

#### Application:

Straight jointing of circular stranded aluminium or copper conductors.

#### Cable Range:

Connector Reference	Stranded Core C.S.A. (mm <sup>2</sup> )			
	Screw Pack 1 (Assembled)		Screw Pack 2 (Alternative)	
	Min	Max	Min	Max
ML20/1-12	25	50	70	95
ML20/2-12	70	95	120	150
ML20/3-12 ML20/3-16	120	150	185	240
ML20/4-12 ML20/4-16 ML20/4-20	240	300	300	400
ML20/5-4H	400	500	500	630

#### Product Description:

The 'ML20' range of mechanical terminations are manufactured from a single piece hot forging thereby ensuring a water proof connection.

The range of connectors utilise the Hepworth shear head technology in the form of direct acting clamping bolts. 'Screw Pack 1' comes assembled with the connector with 'Screw Pack 2' available within the connector bag.

See overleaf for fitting instructions.

'ML20/x-x' Aluminium Mechanical Termination with Moisture/Contaminant Block For Low/Medium Voltage Applications

## MECHANICAL CONNECTORS

### ML20/x-x Aluminium Lugs

#### Physical Dimensions:

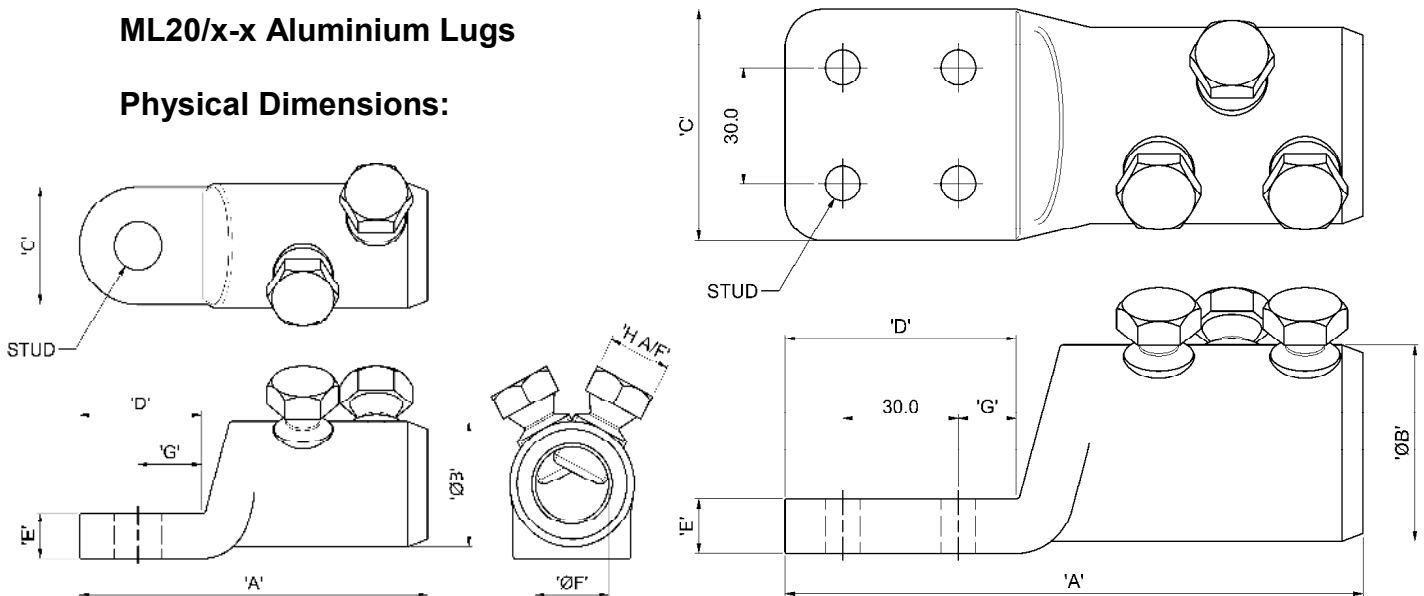

Connector Reference	Dimensions (mm)								
	'A'	'ØB'	'C'	'D'	'E'	'ØF'	'G'	'H A/F'	STUD
ML20/1-12	65	24	24	25.5	8	14	13.5	13	M12
ML20/2-12	88	28	28	29.5	10	16	15.5	17	M12
ML20/3-12	98	34	32	33.5	12	20	17.5	17	M12
ML20/3-16									M16
ML20/4-12	129	42	41	42.5	14	26	22	19	M12
ML20/4-16									M16
ML20/4-20									M20
ML20/5-4H	158	51	60	60	14	34	15	19	4 x M8

**Material:** Aluminium Alloy (Electro-Tinned)

**Test Specification:** BS EN 61238-1 : 2003 - Compression & Mechanical Connectors for power cables for rated voltages up to 36kV.

**Test Report No:** TBC

#### Fitting Instructions:

1. Strip insulation from the core equal to the depth of the bore.
2. Wire brush the exposed conductor core and wipe clean (optional).
3. Align and position the conductor core into the bore ensuring that the core is fully inserted.
4. Torque tighten the shear screws consecutively one turn at a time until the bolts have sheared.
5. De-burr and clean the connector as appropriate.