

Service / Mains,
Neutral / Earth
Connectors

MECHANICAL CONNECTORS

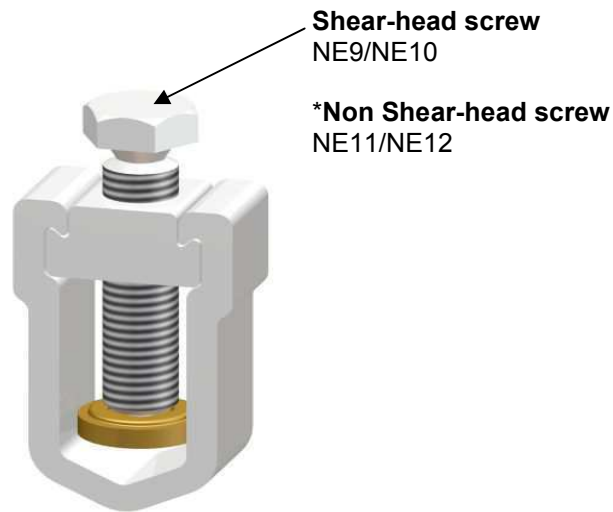

NE Connectors (ALUMINIUM ALLOY)



Principle Application

Stranded aluminium and copper neutral/earth (CNE) conductors.

Range

Ref. Code	Conductor c.s.a. (mm ²)	
	min.	max.
NE9	25	150
NE10	140	240
NE11*	25	150
NE12*	25	240

*Note: See technical data overleaf

The Hepworth Neutral Earth Connectors have been designed to connect the stranded copper and stranded aluminium neutral earth conductors of CNE (waveform) service and mains distribution cables.

All joint configurations can be accommodated dependant on the total cross sectional area of neutral/earth conductor to be jointed.

Each connector is supplied complete with brass gauze as standard.

See overleaf for fitting instructions.

NE Connectors

Physical Dimensions

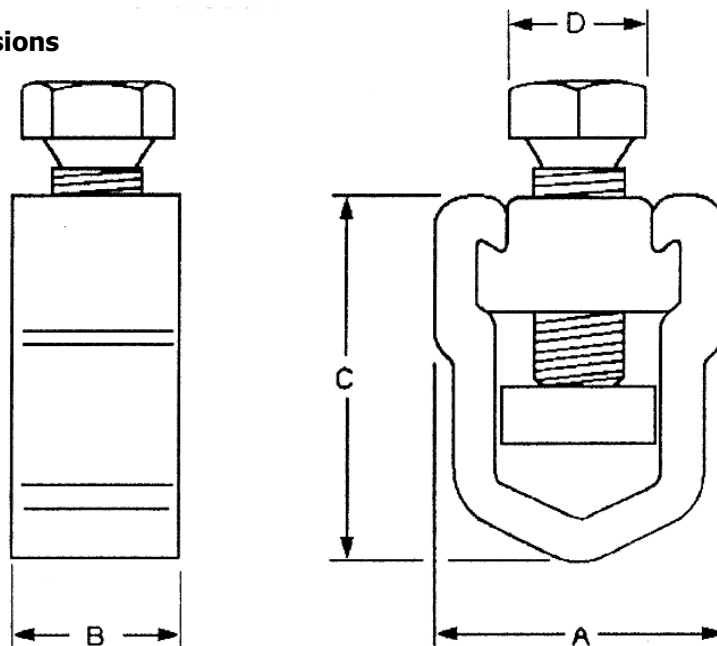

Ref. Code	Dimensions (mm)			
	A	B	C	D
NE9	28.5	16.0	36.0	13.0
NE10	28.5	16.0	46.0	13.0
NE11	28.5	16.0	36.0	13.0
NE12	28.5	16.0	46.0	13.0

Material

Body: Aluminium Alloy

Screw: Aluminium/Brass

Test Specification: Engineering recommendation C79.

Test report numbers—NE9/½A7ONE/½A7ONE

Fitting Instructions

1. Arrange the CNE conductors into the required number of bunches for the particular joint and, where necessary, cut the conductors to length.
2. Thoroughly abrade all conductors around the assembly area.
3. Fit the yoke around the conductors, insert the bridge piece and tighten the screw until positive location is achieved.
4. If the connector employs a shear head system (NE9, NE10), check for even distribution of the conductors before finally tightening the screw until the head shears.

Note: When jointing CNE aluminium to copper conductors ensure the supplied brass gauze is fitted around the copper conductors only.