

Insulation-piercing
straight-through mains
connectors with service
facility

MECHANICAL CONNECTORS

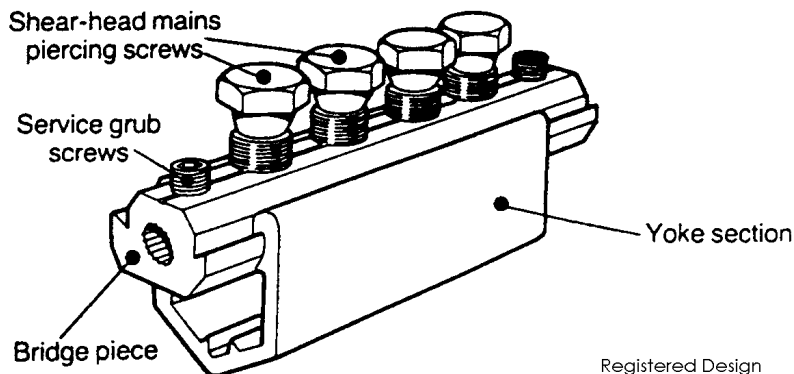

PCM2 Connector



Principle Application

Combined straight-through mains and service connections for live jointing of solid sector aluminium mains cables

Range

Connector Reference	Core csa (mm ²)			Approx Unit Wt. (grams)
	Mains		Service	
	Min	Max	Max*	
PCM2/1	50	95	35	170
PCM2/2	95	185	35	250
PCM2/3	120	300	35	370

*Note: For small section conductors see technical data overleaf.

The Hepworth mechanical connector PCM2 is designed for live straight-through connections of three or four core solid aluminium mains conductors, with the additional facility of connecting either one or two services from the same joint. This may be useful in reducing the overall number of the conventional service joints in a distribution network, or when carrying out repairs involving the replacement of a length of damaged LV mains cable.

Each connector is supplied in a sealed pack together with fitting instructions, details of which appear with the technical data overleaf.



THORNE &
DERRICK
INTERNATIONAL

Thorne & Derrick
+44 (0) 191 410 4292
www.powerandcables.com

Insulation-piercing
straight-through mains
connectors with service
facility

MECHANICAL CONNECTORS

PCM2 Connector

Physical Dimensions

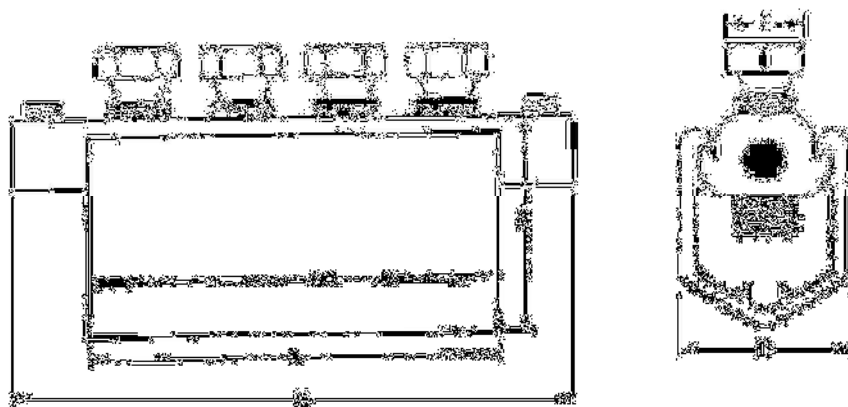

Ref Code	Dimensions (mm)				
	A	B	C	D	E
PCM2/1	90	115	37.7	26.2	13.0
PCM2/2	100	125	43.6	33.2	17.0
PCM2/3	120	145	48.1	40.2	17.0

Material

Aluminium Alloy

Fitting Instructions

Align the cores to be connected and loosely assemble the connectors around the cores, making sure that it is centrally located. Cut the service cables(s) to length and strip back 15mm of insulation. Thoroughly abrade the exposed service conductor(s), insert into the bridge piece up to the insulation and tighten the grub screws using a 5/32" or 4mm A/F hexagonal drive. The mains connection is completed by tightening the mains screws consecutively, one turn at a time, until the heads are sheared from all four screws.

These connectors have been designed to accept each mains conductor in either normal (apex-down) or cross-cored configurations.

Stranded service conductors below 16mm² should be doubled, and if necessary redoubled, and if copper conductors are to be jointed, they should be wrapped in brass gauze to improve the electrical stability of the interface connection.



THORNE &
DERRICK
INTERNATIONAL

Thorne & Derrick
+44 (0) 191 410 4292
www.powerandcables.com