

PCS2 Connectors

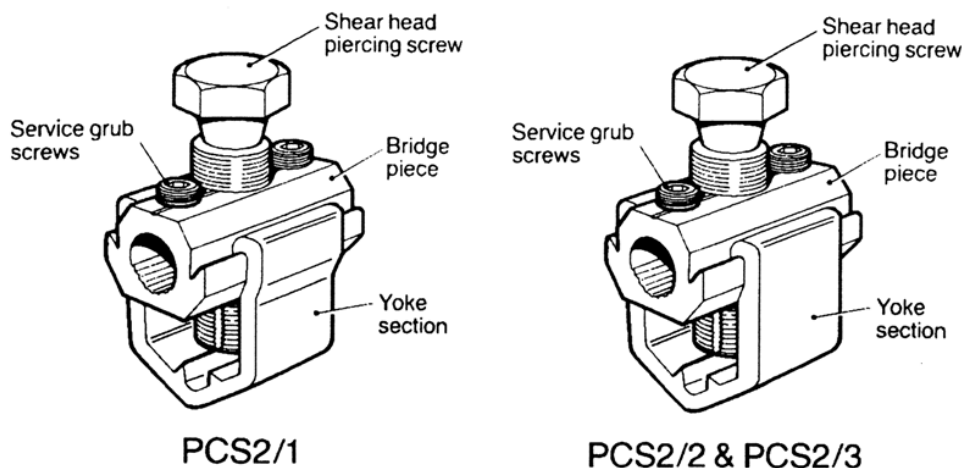

Principle Application

Service connections from solid 3-core aluminium mains conductors.

Range

Connector Reference	Core c.s.a. (mm ²)		Approx Unit Wt. (grams)
	Mains	Service	
	max.	max.*	
PCS2/1	70	35	69
PCS2/2	120	35	98
PCS2/3	240	35	125

*NOTE: For small section conductors see technical data overleaf

The Hepworth PCS2 range of insulation-piercing service connectors has been specifically designed for live jointing, and offers an improved level of safety together with a convenient and reliable method of connection service cables to three core solid aluminium M.I.N.D. paper insulated mains conductors (CONSAC). The connector is suitable for either single or double service configurations.

Each connector is supplied with either an insulation patch or a P.V.C. shroud as standard in a sealed pack, together with fitting instructions, details of which are included with technical data overleaf.

PCS2 Connectors

Physical Dimensions

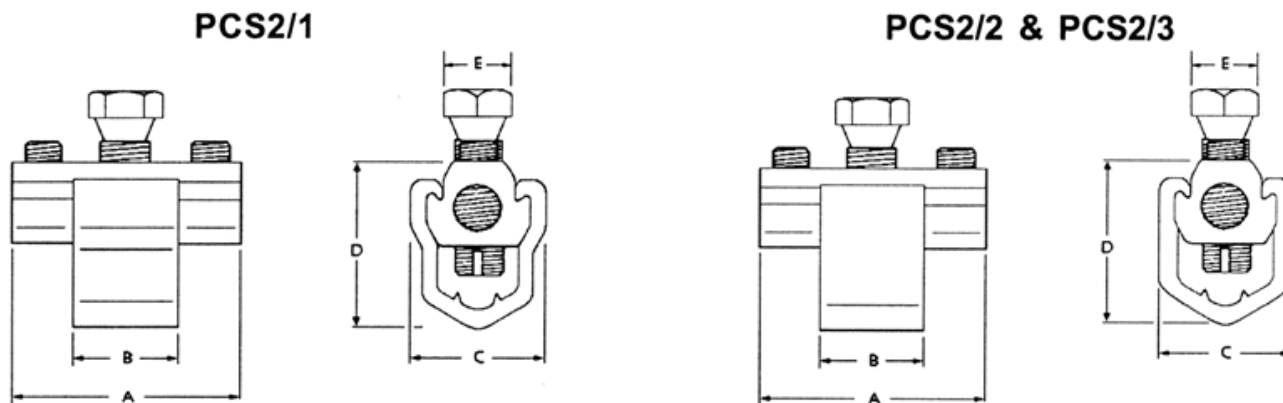

Ref. Code	Dimensions (mm)				
	A	B	C	D	E
PCS2/1	45.0	20.0	26.2	32.5	13.0
PCS2.2	45.0	20.0	26.2	37.7	13.0
PCS2/3	45.0	20.0	33.2	43.6	17.0

Material

Aluminium Alloy.

Fitting Instructions

Separate the cores sufficiently to allow the yoke section to be fitted around the conductor, and loosely assemble the components in the required position, ensuring that the bridge piece is centrally located in the yoke. Cut each service cable to length and strip back 15 mm of insulation from each conductor. (NOTE: Excessive stripping of the service conductors may introduce the risk of fouling the central piercing screw). Thoroughly abrade each service conductor, insert into the bridge piece, and tighten the grub screws using a 5/32" or 4 mm A/F hexagonal drive.

The connection is then completed by tightening the central piercing screw until the head shears. (NOTE: It is during this operation that the assembly, including the service conductors, will become live). Insulate the connector with either shroud or patch as appropriate.

Stranded conductors below 16 mm² should be double and if necessary redoubled. If copper conductors are to be jointed, they should be wrapped in brass gauze to improve the stability of the interlace connection.