

'USMLx' Aluminium
Mechanical Termination with
Moisture/Contaminant Block For
Medium Voltage Applications

MECHANICAL CONNECTORS



USMLx Aluminium Lugs



**USML1
USML2**



**USML3
USML8**

Application:

Termination of circular stranded aluminium or copper conductors.

Cable Range:

Connector Reference	Stranded Core C.S.A. (mm ²)	
	Min	Max
USML1	25	120
USML2	50	240
USML3	240	500
USML8	400	630

Product Description:

The 'USML' range of mechanical terminations are manufactured from a single piece hot forging thereby ensuring a water proof connection.

The product utilise the patented universal range taking shear bolts.
(USA Patent No's 6209424 & 6321624)

It is recommended that the appropriate tooling is to be used at all times, typical examples shown below.

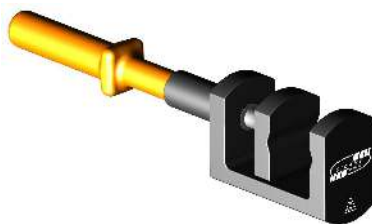

'JTS/22 BR Holding Tool



'JTS/9' 1/2" sq Driver



**THORNE &
DERRICK
INTERNATIONAL**

Thorne & Derrick
+44 (0) 191 410 4292
www.powerandcables.com

'USMLx' Aluminium
Mechanical Termination with
Moisture/Contaminant Block For
Medium Voltage Applications

MECHANICAL CONNECTORS

USMLx Aluminium Lugs

Product Dimensions:

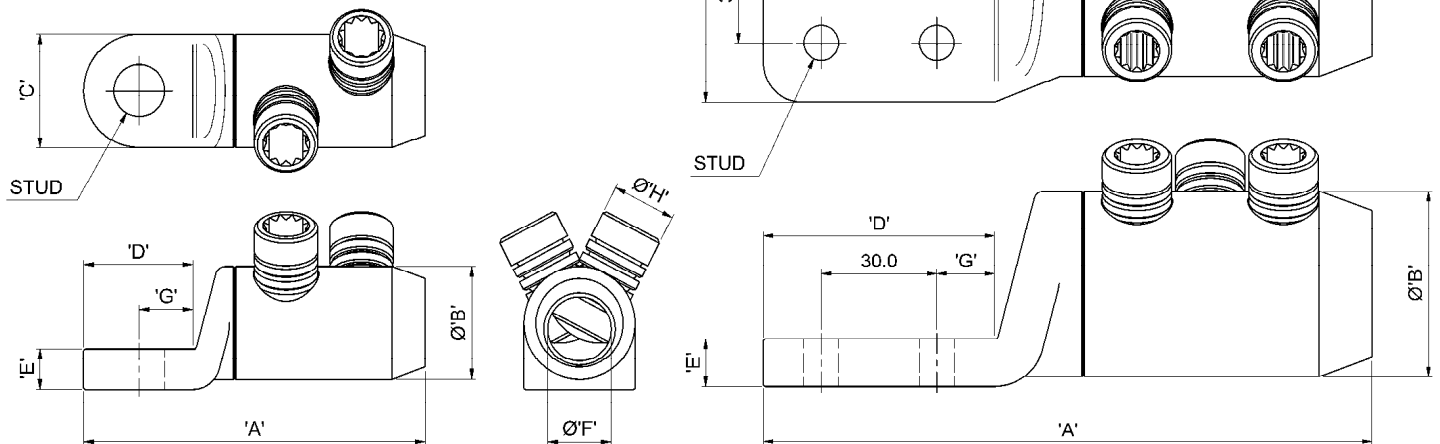

Connector Reference	Dimensions (mm)								
	'A'	'ØB'	'C'	'D'	'E'	'ØF'	'G'	'ØH'	STUD
USML1	88	28	28	29.5	10	16	15.5	M16	M12
USML2	98	34	32	33.5	12	21	17.5	M16	M12
USML3	158	47	60	60	12	30	15	M18	4 x M8
USML8	158	51	60	60	14	34	15	M18	4 x M8

Material: Aluminium Alloy (Electro-Tinned)

Test Specification: TBC

Test Report No: TBC

Fitting instructions:

1. Strip insulation from each core equal to the depth of the bore.
2. Wire brush the exposed conductor cores and wipe clean (optional).
3. Align and position the conductor cores in each of the bores ensuring that the core is fully inserted to the centre wall.
4. Fit the universal shear screws within the connector and torque tighten one turn at a time, using the correct tool, until the bolts have sheared.
5. De-burr and clean the connector as appropriate **ensuring the profile of the screws are level with the connector body and leaving no sharp edges.**



THORNE &
DERRICK
INTERNATIONAL

Thorne & Derrick
+44 (0) 191 410 4292
www.powerandcables.com