

CAUTION : Read instructions thoroughly and completely prior to beginning installation.

Installation instructions for separable elbow connectors
 Type A interface on copper wire screened cables

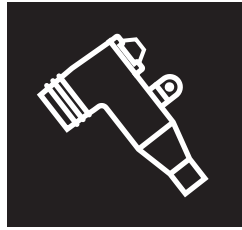

(K)158LR

For sizes FB - FG - GA - GAB - GH

Required components for the connector installation :

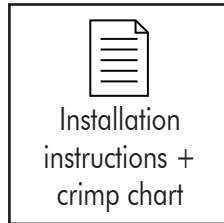
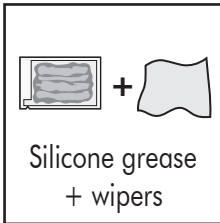
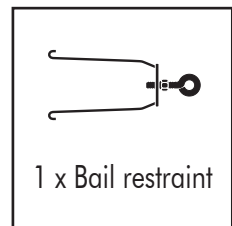
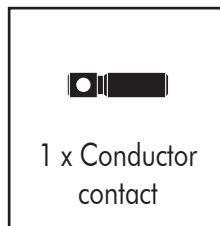
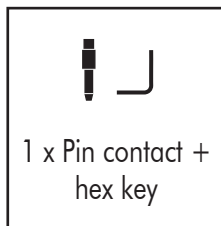
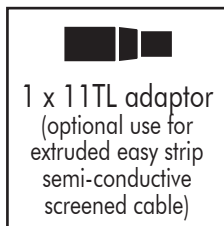
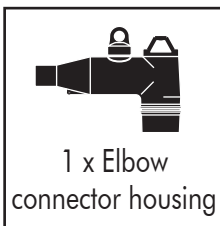

Further required components depending on the application (optional supply) :

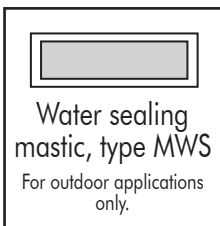

SELECT CABLE TYPE BELOW

A

Extruded easy strip semi-conductive screen
Go to page 2

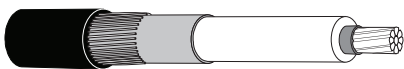

B

Bonded extruded semi-conductive screen
Go to page 4

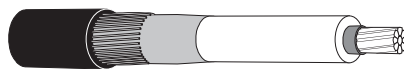

C

Fabric tape screen (graphite)
Go to page 6

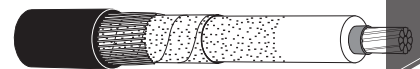

Euromold
 a Nexans company

This product should be installed only by competent personnel trained in good safety practices involving high voltage electrical equipment. These instructions are not intended as a substitute for adequate training or experience in such safety practices. These instructions do not attempt to provide for every possible contingency. Failure to follow these instructions could result in damage to the product and serious or fatal injury. **IMPORTANT** : Cable and associated apparatus must be de-energised, locked out, and tagged prior to product installation.

FOR INFORMATION ONLY Please always use the instructions supplied in the kit

A

Extruded easy strip semi-conductive screen

CABLE DISPOSAL

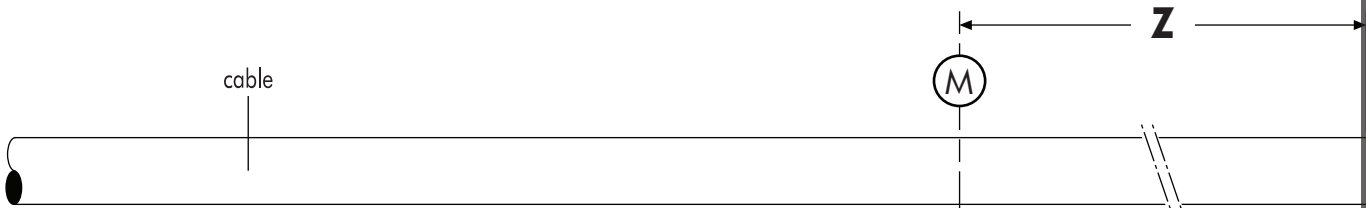

- 1 Train the cable into the approximate finished position next to the equipment bushing.
- 2 The distance « Z » mm between cable end and centre line « M » of the bushing must be long enough to connect the copper screen wires to the system earth once the connector is installed on the equipment.

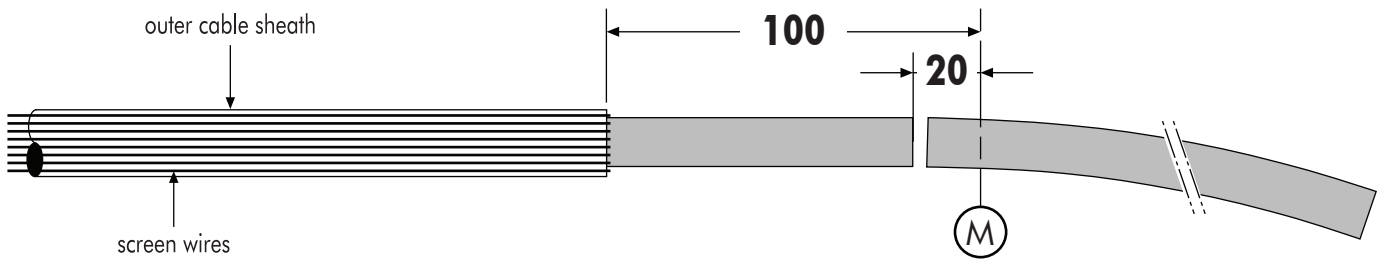
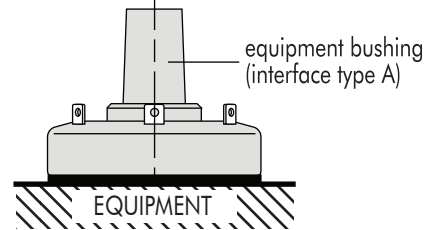

- 3 Temporarily remove the outer sheath to a point 100 mm from the centre line of the bushing.
Do not cut or nick the wire screen.
- 4 Bend back screen wires along the outer sheath.
- 5 Cut the cable to a point 20 mm from the centre line « M » of the bushing.

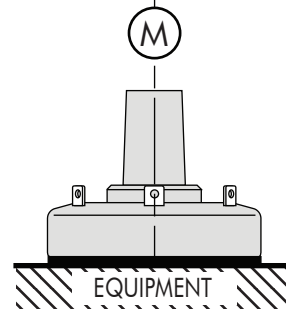

CRIMPING OF THE CONTACT

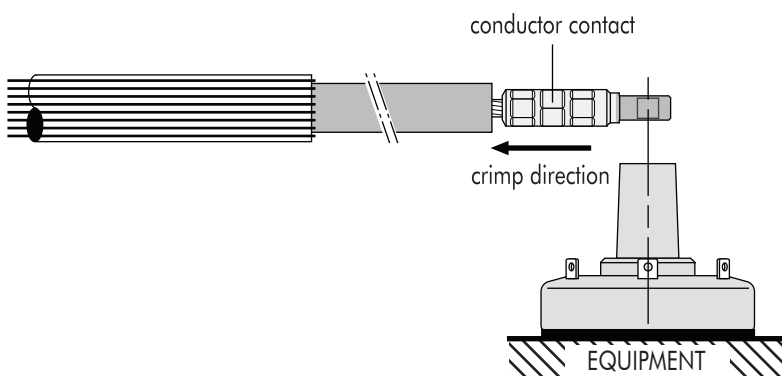
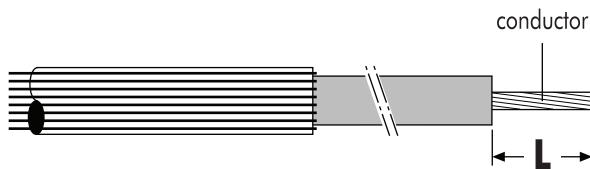

- 1 Bare the conductor for a distance « L » mm from the cable end.
Copper conductor : L = 40 mm;
Aluminium conductor : L = 50 mm.
- 2 Before installing the crimp contact wire brush the conductor (for aluminium conductors).
- 3 Install the crimp contact, check the contact palm faces the bushing interface.
- 4 Crimp the contact on the conductor.
Wipe-off excess inhibitor.

FOR INFORMATION ONLY Please always use the instructions supplied in the kit

CABLE PREPARATION AND INSTALLATION OF THE 11TL ADAPTOR (if required)

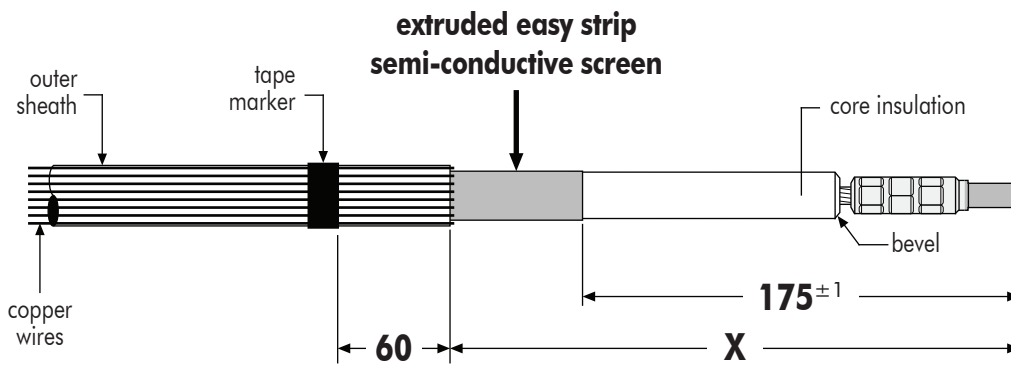

Adaptor used	X (mm)
none	205
11TL	230

- 1 Remove the outer sheath to a point « X » mm from the end of the crimped contact.
- 2 If an 11TL adaptor is used, apply a tape marker on the outer sheath **60** mm from the end.
- 3 Remove the extruded semi-conductive screen to a point **175±1** mm from the end of the crimped contact.
- 4 Slightly bevel the edge of the core insulation (2 mm max.). **Do not pencil.**
- 5 **If no 11TL adaptor is used, proceed on page 8 : "Connector installation".**

6 Outdoor applications :

Apply one layer of water sealing mastic (type MWS) on the outer sheath, flush with the end (**25** mm minimum width). Bend back screen wires along the outer sheath and compress the screen wires into the sealing mastic.

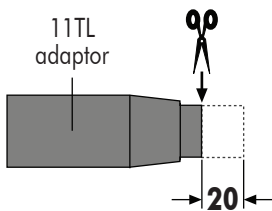
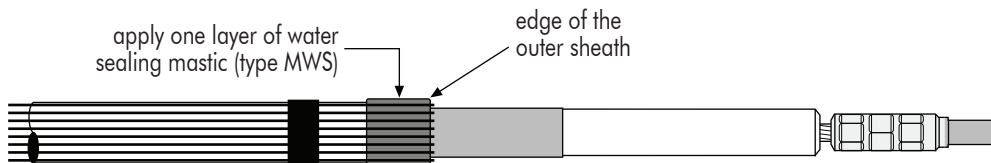

- 7 Cut the collar of the 11TL adaptor for a distance of **20** mm.

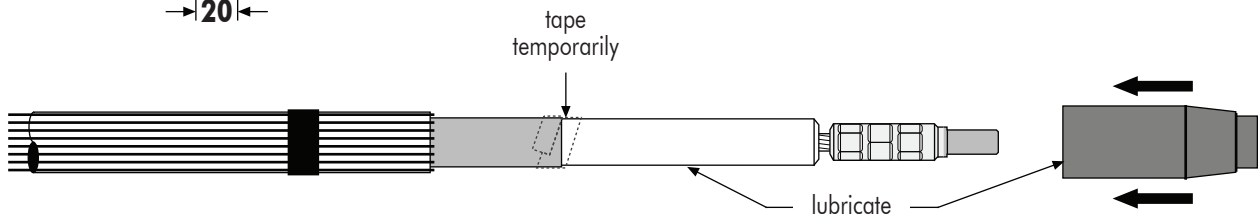

- 8 As an aid to install the adaptor, it is recommended to wrap one or two layers adhesive tape on the step of the extruded semi-conductive screen.
- 9 Lubricate* core insulation and inside of the adaptor.

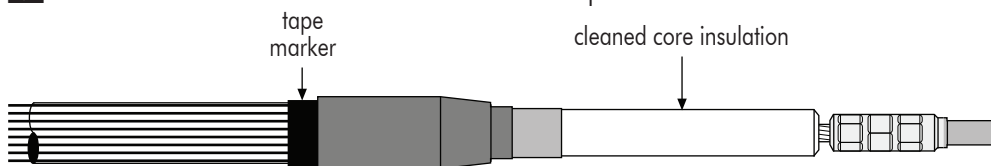

- 10 Slide the adaptor over the insulation until flush with the tape marker.
- 11 Remove the adhesive tape applied in step 8.
- 12 **Using the white wiper, thoroughly clean the core insulation.**
Always wipe towards the screen wires.

Proceed on page 8 for the connector installation

* USE ONLY THE SILICONE LUBRICANT SUPPLIED

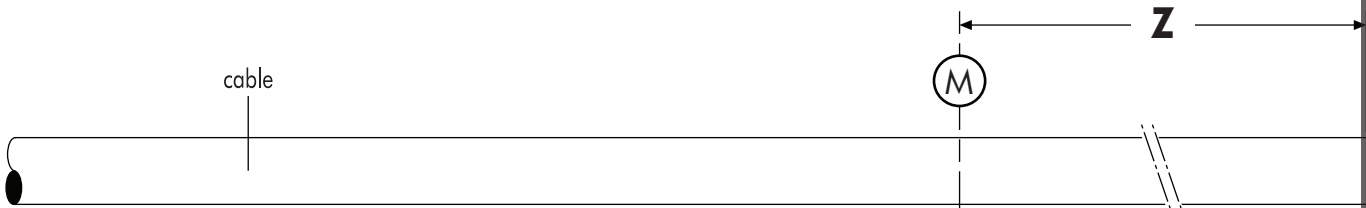
B**Bonded extruded semi-conductive screen****CABLE DISPOSAL**

- 1 Train the cable into the approximate finished position next to the equipment bushing.
- 2 The distance « Z » mm between cable end and centre line « M » of the bushing must be long enough to connect the copper screen wires to the system earth once the connector is installed on the equipment.

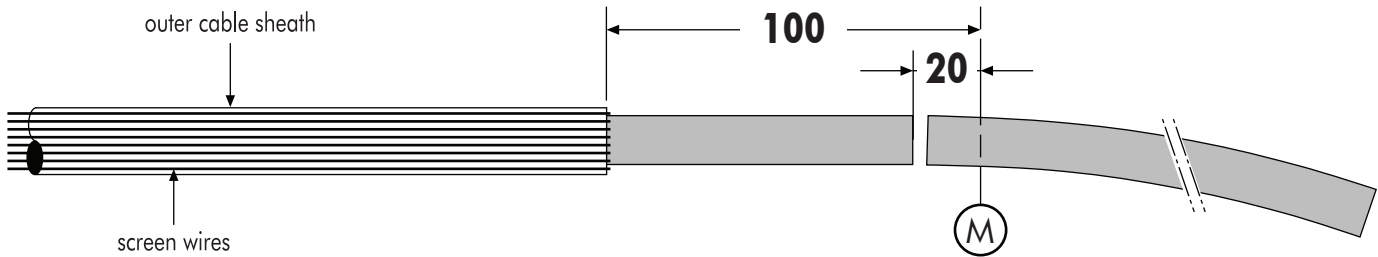
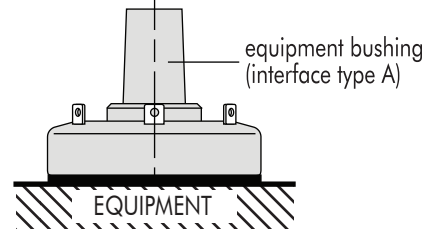

- 3 Temporarily remove the outer sheath to a point **100** mm from the centre line of the bushing.
Do not cut or nick the wire screen.
- 4 Bend back screen wires along the outer sheath.
- 5 Cut the cable to a point **20** mm from the centre line « M » of the bushing.

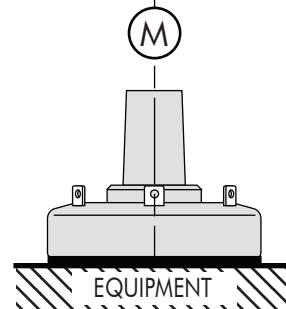
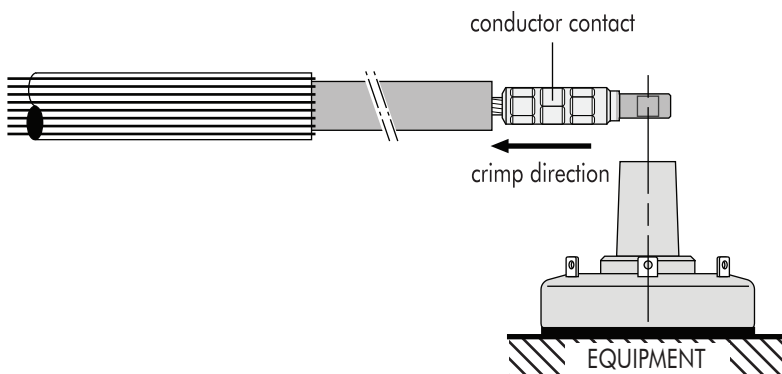
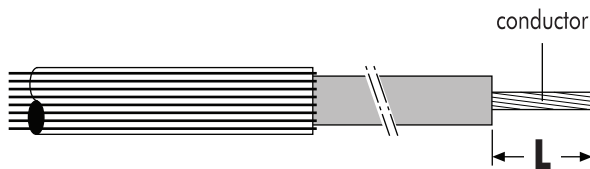
**CRIMPING OF THE CONTACT**

- 1 Bare the conductor for a distance « L » mm from the cable end.
Copper conductor : L = 40 mm;
Aluminium conductor : L = 50 mm.
- 2 Before installing the crimp contact wire brush the conductor (for aluminium conductors).
- 3 Install the crimp contact, check the contact palm faces the bushing interface.
- 4 Crimp the contact on the conductor.
Wipe-off excess inhibitor.

FOR INFORMATION ONLY Please always use the instructions supplied in the kit

CABLE PREPARATION AND INSTALLATION OF THE 11TL ADAPTOR

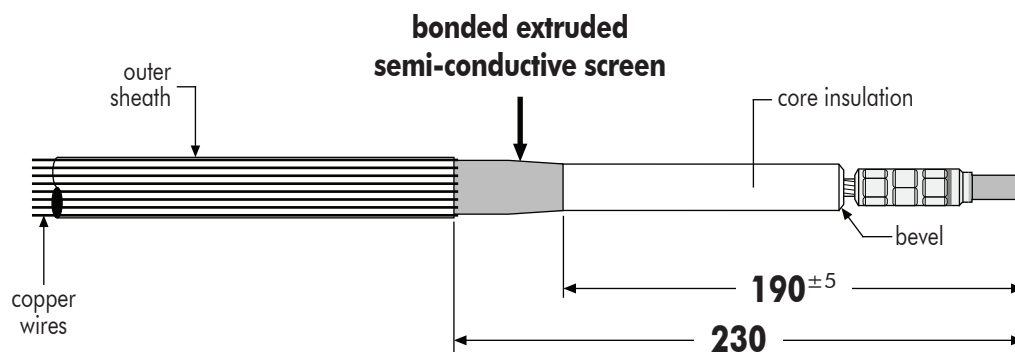

- 1 Remove the outer sheath to a point **230** mm from the end of the crimped contact.
- 2 Using a pencilling tool, remove the extruded semi-conductive screen to a point **190 \pm 5** mm from the end of the crimped contact.
- 3 Slightly bevel the edge of the core insulation (2 mm max.). **Do not pencil.**

4 Outdoor applications :

Apply one layer of water sealing mastic (type MWS) on the outer sheath, flush with the end (**25** mm minimum width). Bend back screen wires along the outer sheath and compress the screen wires into the sealing mastic.

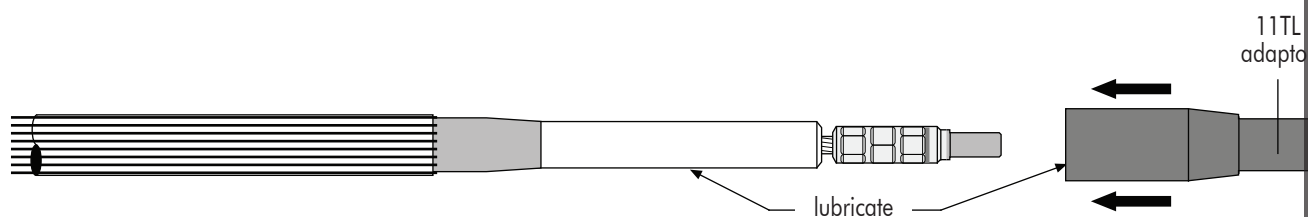
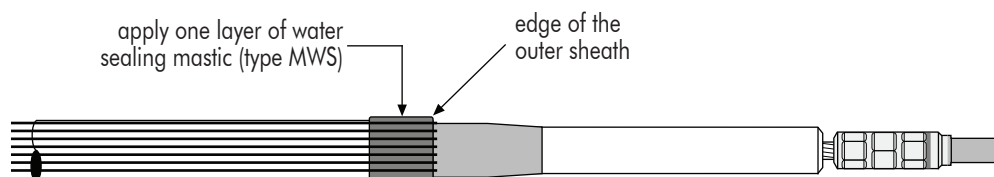

- 5 Lubricate* core insulation and inside of the adaptor.

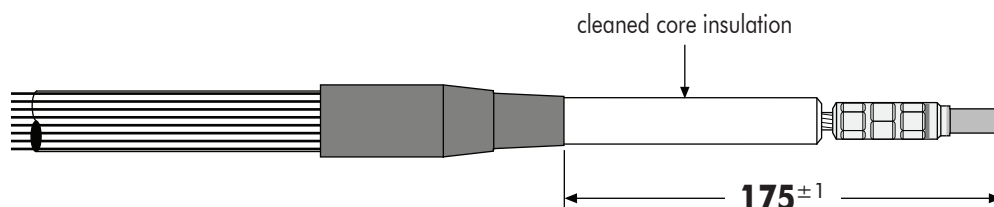

- 6 Slide the adaptor up to a point **175 \pm 1** mm from the end of the crimped contact. **Using an appropriate solvent, thoroughly clean the core insulation.** Always wipe towards the screen wires.

Proceed ON page 8 for the connector installation

* USE ONLY THE SILICONE LUBRICANT SUPPLIED



FOR INFORMATION ONLY Please always use the instructions supplied in the kit



C

Fabric tape screen (graphite)

CABLE DISPOSAL



- 1 Train the cable into the approximate finished position next to the equipment bushing.
- 2 The distance « Z » mm between cable end and centre line « M » of the bushing must be long enough to connect the copper screen wires to the system earth once the connector is installed on the equipment.

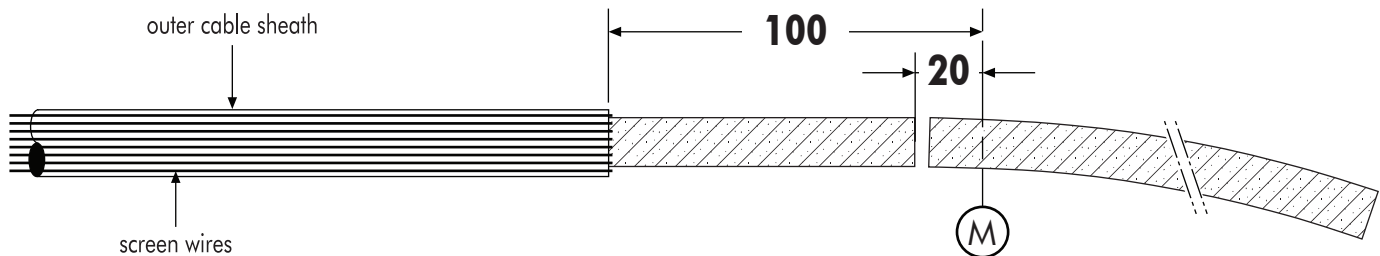
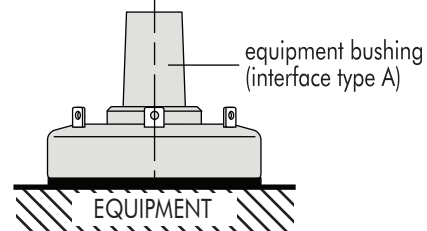

- 3 Temporarily remove the outer sheath to a point 100 mm from the centre line of the bushing.
Do not cut or nick the wire screen.
- 4 Bend back screen wires along the outer sheath.
- 5 Cut the cable to a point 20 mm from the centre line « M » of the bushing.

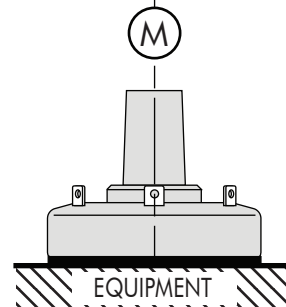

CRIMPING OF THE CONTACT

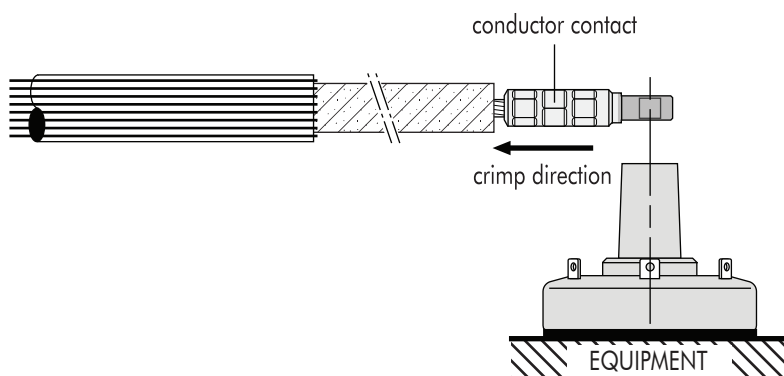
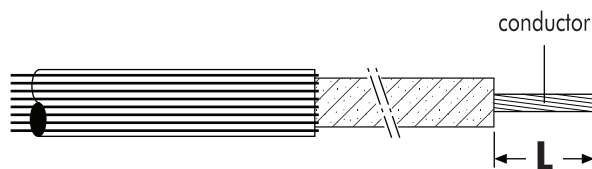

- 1 Bare the conductor for a distance « L » mm from the cable end.
Copper conductor : L = 40 mm;
Aluminium conductor : L = 50 mm.
- 2 Before installing the crimp contact wire brush the conductor (for aluminium conductors).
- 3 Install the crimp contact, check the contact palm faces the bushing interface.
- 4 Crimp the contact on the conductor.
Wipe-off excess inhibitor.

FOR INFORMATION ONLY Please always use the instructions supplied in the kit

CABLE PREPARATION AND INSTALLATION OF THE 11TL ADAPTOR

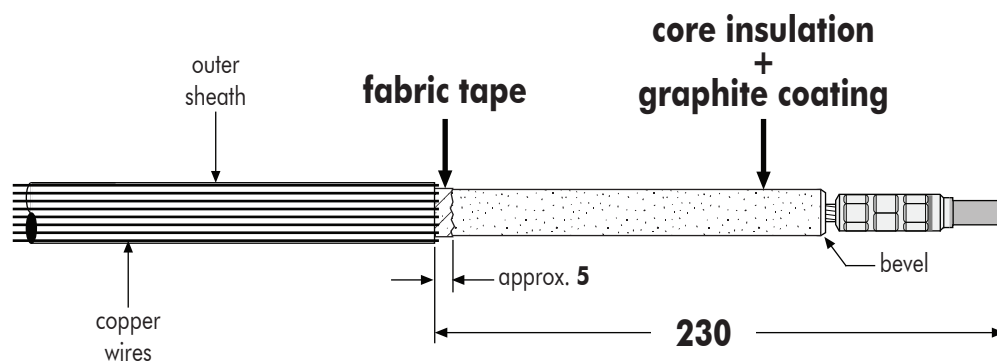

- 1** Remove the outer sheath to a point **230** mm from the end of the crimped contact.
- 2** Remove the fabric tape to a point approx. **5** mm from the outer sheath.
Do not remove the graphite varnish at this stage.
- 3** Slightly bevel the edge of the core insulation (2 mm max.). **Do not pencil.**

4 Outdoor applications :

Apply one layer of water sealing mastic (type MWS) on the outer sheath, flush with the end (**25** mm minimum width). Bend back screen wires along the outer sheath and compress the screen wires into the sealing mastic.

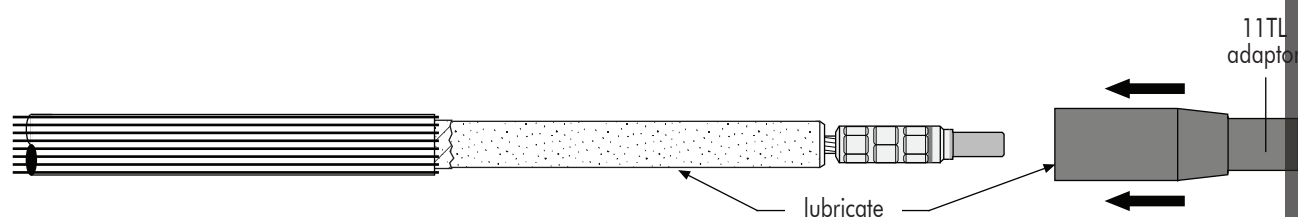
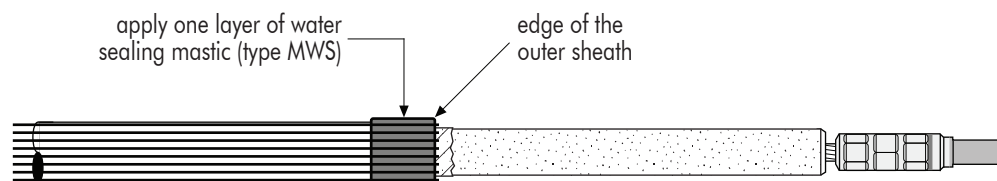

- 5** Lubricate* core insulation and inside of the adaptor.

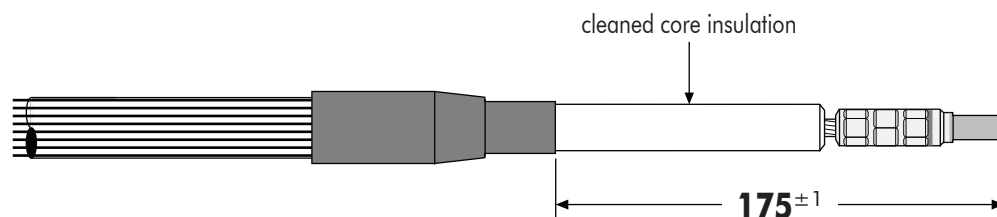

- 6** Slide the adaptor up to a point **175^{±1}** mm from the end of the crimped contact.
Thoroughly remove the graphite coating using an appropriate solvent.
Always wipe towards the screen wires.



FOR INFORMATION ONLY Please always use the instructions supplied in the kit



A B C

Applies to all cable types

CONNECTOR INSTALLATION AND CABLE SCREEN EARTHING

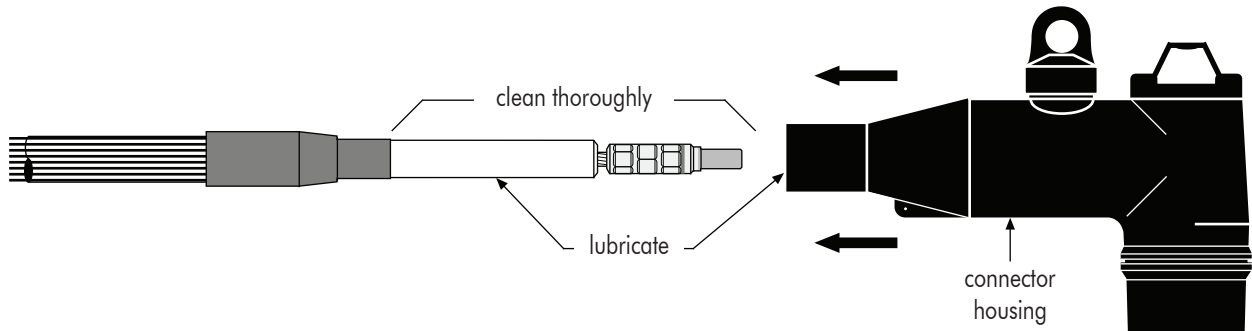

- 1** Remove any traces of conductive residue from the core insulation above the adaptor end or extruded semi-conductive screen. Always wipe towards the screen wires.
- 2** Lubricate* the core insulation and inside surface of the elbow connector.
- 3** Check if the angle of the connector housing is correct relative to the palm of the crimp contact and gently slide the housing on the cable until it cannot advance any further.

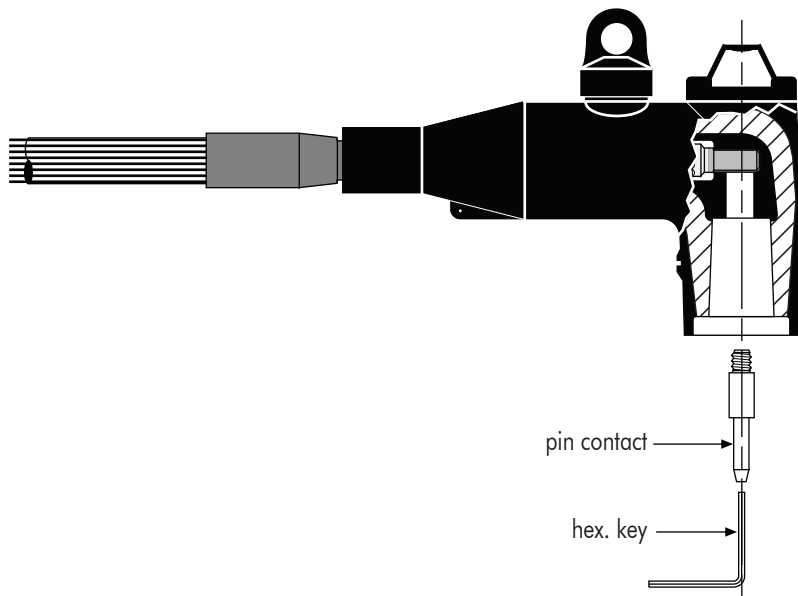

- 4** Insert the threaded end of the pin contact into the mating part by hand. **Take care not to cross thread.**
- 5** Tighten with hex. key until the key has taken a set.

Installation with 11TL adaptor

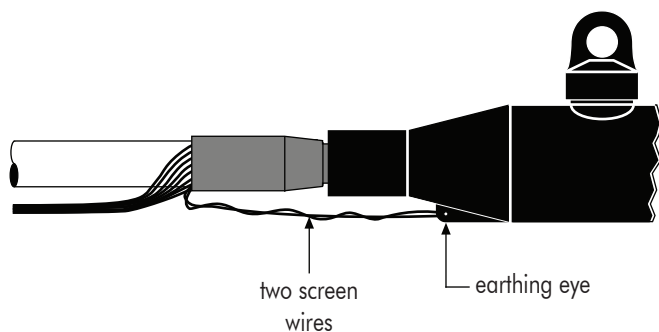

Installation without 11TL adaptor

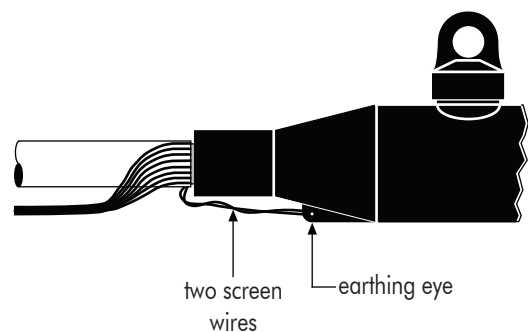

- 6** Connect two copper screen wires to the earthing eye of the elbow connector.

* USE ONLY THE SILICONE LUBRICANT SUPPLIED

FOR INFORMATION ONLY Please always use the instructions supplied in the kit

CONNECTOR INSTALLATION ON BUSHING

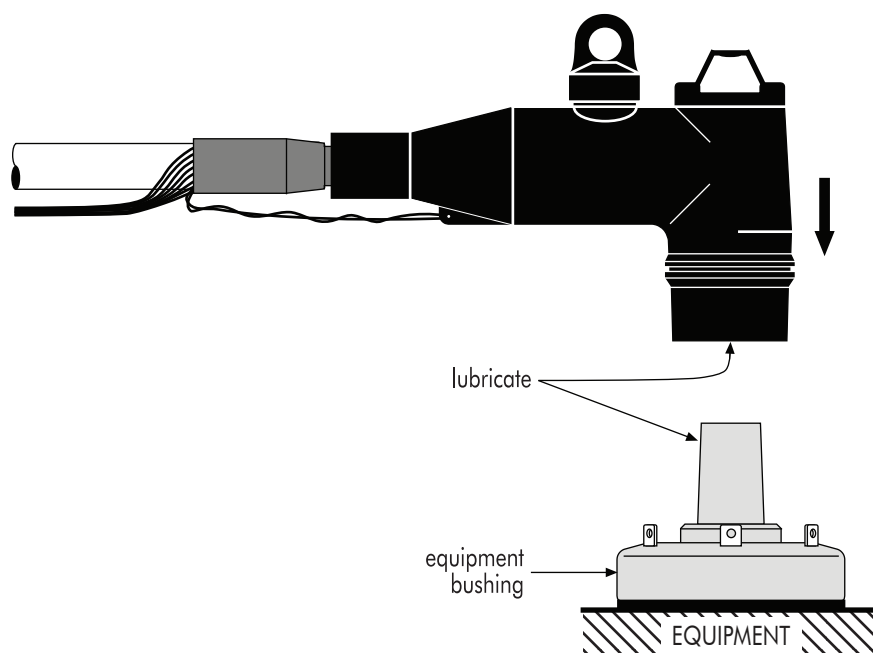

- 1 Clean and lubricate* lightly both bushing interface and connector interface.
- 2 Push the elbow connector on the bushing.

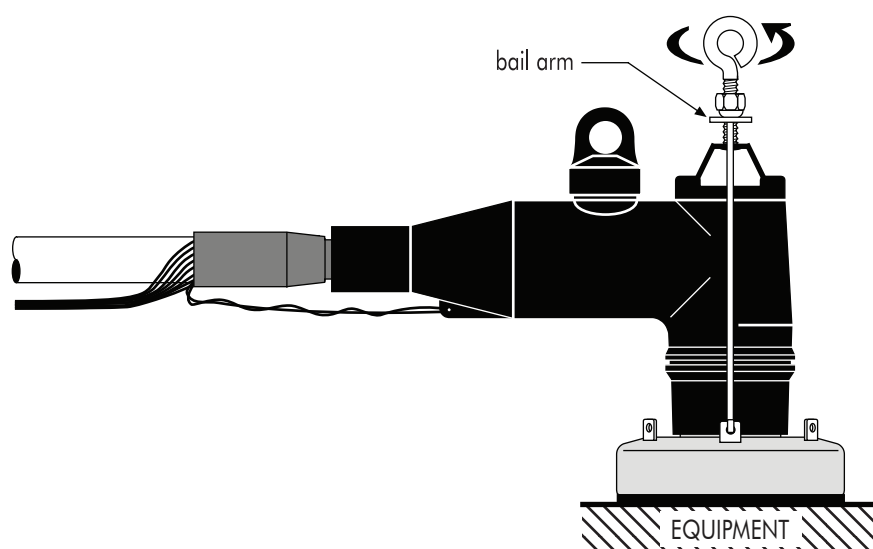

- 3 Insert bail arm into the bushing tabs.
- 4 Position bail arm and tighten eye bolt.

Do not apply excessive force on the elbow connector.

Adjust the nut on the eye bolt until it allows the eye bolt to seat securely on the locator. The nut should act as a stop to prevent the eye bolt from applying excessive force on the elbow connector.

Once the nut is in final position, it will not have to be readjusted when removing and replacing the elbow connector.



FOR INFORMATION ONLY Please always use the instructions supplied in the kit



EARTHING AND CABLE CLAMPING

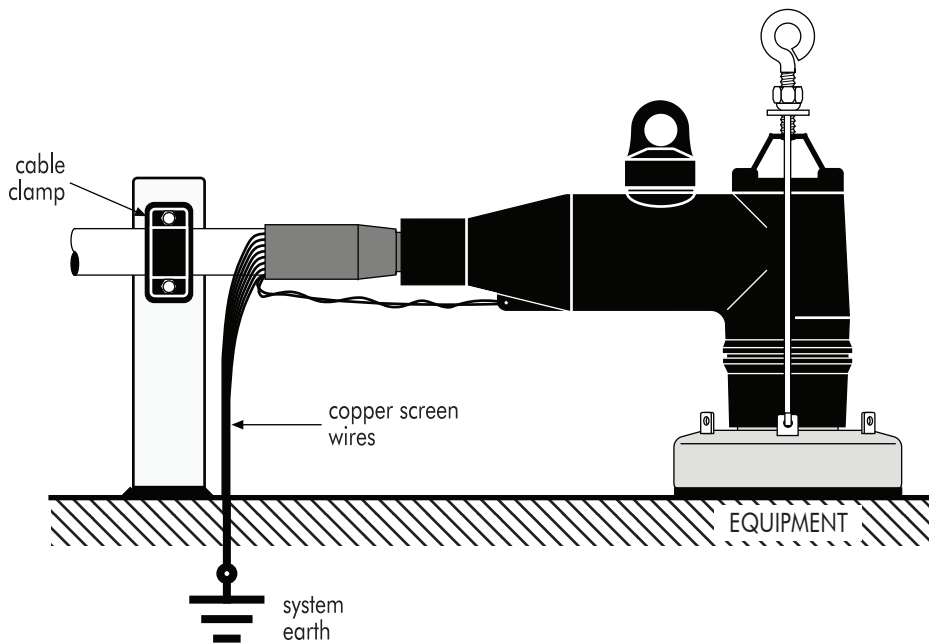

- 1 Bend back the screen wires along the outer sheath to form a pig tail.
- 2 Connect the screen wires to the system earth.

NOTE :

A connector/bushing mated combination should not be allowed to carry the full weight of the cable. Therefore it is necessary to clamp the cable as close as possible to the connector.

IMPORTANT NOTES :

- Never disconnect the straight connector from energised equipment nor energise a disconnected straight connector without previously installing on its corresponding Stand-off plug (K)151SOP or dead-end plug (K)150DP.
- Do not allow hydrocarbon oils or solvents to contaminate the E.P.D.M. rubber. In the event of contamination, wipe the surface clean with a dry cloth.

