

400PB-10SA

INTERFACE C SURGE ARRESTER

APPLICATION

Surge arrester designed to protect medium voltage components, including transformers, equipment, cable and accessories from high voltage surges resulting from lightning or switching.

DESIGN

Surge arrester comprising:

1. Conductive EPDM insert.
2. Conductive EPDM jacket.
3. Insulating EPDM layer moulded between the insert and the jacket.
4. Contact rod.
5. Earthing lead.
6. Earth connection.
7. Steel cap.
8. Metal oxide valve elements.
9. Type C - 630 A interface as described by CENELEC EN 50180 and 50181.

SPECIFICATIONS AND STANDARDS

The 400PB-10SA surge arresters meet the test requirements of IEC 60099-4.

TECHNICAL CHARACTERISTICS

- This surge arrester is a metal oxide varistor surge arrester in an elbow configuration.
- Each arrester is tested for AC withstand, partial discharge and critical voltage prior to leaving the factory.

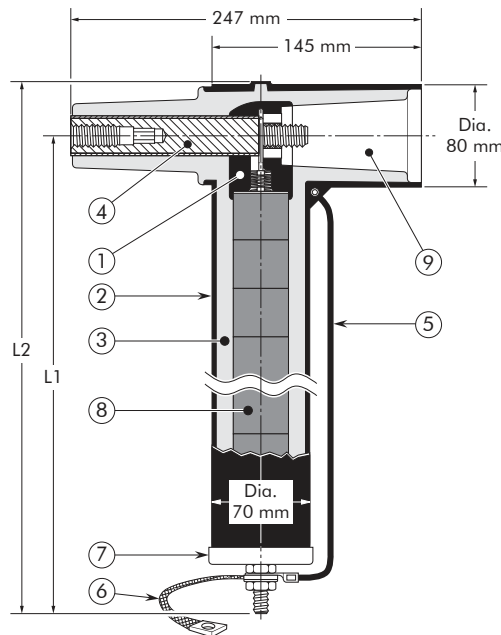

- 6/10 (12) kV
- 6.35/11 (12) kV
- 8.7/15 (17.5) kV
- 12/20 (24) kV
- 12.7/22 (24) kV
- 18/30 (36) kV
- 19/33 (36) kV
- 20.8/36 (42) kV

Up to 42 kV

EUROMOLD®

Surge arrester type	Nominal discharge current In (kA)	Rated voltage Ur (kV)	Max. continuous operating voltage Uc (kV)	Dimensions (mm)	
				L1	L2
400PB-10SA-15L	10	15	12.0	270	310
400PB-10SA-18L	10	18	14.4	270	310
400PB-10SA-22L	10	22	17.6	370	410
400PB-10SA-24L	10	24	19.2	370	410
400PB-10SA-30L	10	30	24.0	370	410
400PB-10SA-6N	10	6	4.8	270	310
400PB-10SA-9N	10	9	7.2	270	310
400PB-10SA-12N	10	12	9.6	270	310
400PB-10SA-15N	10	15	12.0	270	310
400PB-10SA-18N	10	18	14.4	270	310
400PB-10SA-22N	10	22	17.6	270	310
400PB-10SA-24N	10	24	19.2	370	410
400PB-10SA-30N	10	30	24.0	370	410
400PB-10SA-33N	10	33	26.4	370	410
400PB-10SA-36N	10	36	28.8	370	410
400PB-10SA-45N	10	45	36.0	470	510
400PB-10SA-51N	10	51	40.8	470	510

05/2017

TYPICAL APPLICATIONS AND DIMENSIONS

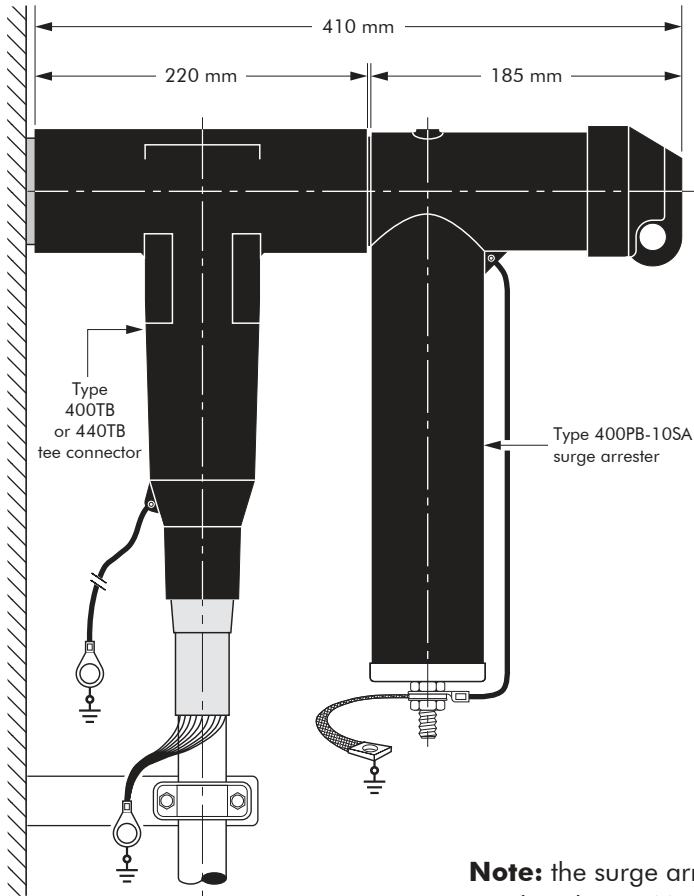

Note: the surge arrester body needs to be positioned vertically after installation.

ORDERING INSTRUCTIONS

To order the surge arrester, specify the surge arrester type, as described on previous page.

EXAMPLE:

For a maximum continuous operating voltage (r.m.s.) of 24 kV and a nominal discharge current of 10 kA. Order a 400PB-10SA-30N surge arrester.

TECHNICAL DATA

Surge arrester type	Steep current residual voltage @ 10 kA [1/20 μs] (kV)	Lightning current residual voltage [8/20 μs] (kV)			Switching impulse residual voltage [36/90 μs] (kV)		High current impulse withstand (kA)
		@ 5 kA	@ 10 kA	@ 20 kA	@ 125 A	@ 500 A	
400PB-10SA-15L	47.1	38.9	42.3	47.4	29.8	31.8	100
400PB-10SA-18L	56.5	46.7	50.8	56.9	35.8	38.2	100
400PB-10SA-22L	69.2	57.1	62.2	69.7	43.8	46.7	100
400PB-10SA-24L	75.2	62.1	67.6	75.8	47.7	50.8	100
400PB-10SA-30L	94.0	77.6	84.5	94.7	59.6	63.5	100
400PB-10SA-6N	20.4	16.8	18.3	20.5	12.9	13.7	100
400PB-10SA-9N	28.5	23.5	25.6	28.7	18.0	19.2	100
400PB-10SA-12N	38.0	31.4	34.2	38.3	24.1	25.7	100
400PB-10SA-15N	48.1	39.7	43.2	48.4	30.5	32.5	100
400PB-10SA-18N	58.1	48.0	52.2	58.5	36.8	39.2	100
400PB-10SA-22N	70.1	57.9	63.0	70.6	44.4	47.3	100
400PB-10SA-24N	77.0	63.6	69.2	77.6	48.8	52.0	100
400PB-10SA-30N	97.0	80.1	87.2	97.7	61.5	65.5	100
400PB-10SA-33N	103.4	85.4	93.0	104.2	65.6	69.9	100
400PB-10SA-36N	115.9	95.7	104.2	116.8	73.5	78.3	100
400PB-10SA-45N	144.1	119.0	129.5	145.1	91.3	97.3	100
400PB-10SA-51N	166.0	137.1	149.2	167.2	105.2	112.1	100



THORNE &
DERRICK
INTERNATIONAL

Thorne & Derrick¹³
+44 (0) 191 410 4292
www.powerandcables.com