



Shrink Polymer Systems

Cable Installation Materials – 24 volts to 36 kV

Installation Instruction Heatshrink Termination For 3 Core Pilc Belted/Screened Cables 11-36kV

- PLEASE READ INSTRUCTIONS THOROUGHLY BEFORE PROCEEDING
- INSTALLATION SHOULD BE CARRIED OUT BY A TRAINED COMPETENT JOINTER

INDOOR

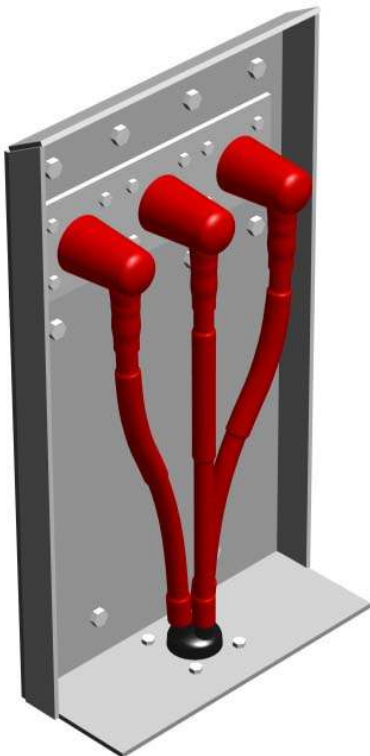

OUTDOOR



ISSUE DATE: 28.06.17

- **General Fitting Instructions**
- **It is highly recommended that suitable tools are utilised for the correct preparation on Paper Cables**
- **Use a propane gas torch with a soft flame**
- **Avoid a pencil like blue flame which is caused by unregulated supply**
- **Keep the flame on the move to ensure even shrinkage of all the materials and also helps to reduce scorching**
- **Ensure that all components are kept clean and grease free during installation**
- **Allow to cool before applying any mechanical strain**

Remove Outer Cable Sheath:

VOLTAGE	INDOOR L	OUTDOOR L	X
7.2kV	600mm	700mm	LENGTH OF LUG BARREL + 10%
12kV	650mm	700mm	
17.5kV	650mm	700mm	
24kV	700mm	800mm	
36kV	800mm	900mm	

Table 1

Alternative tail lengths available upon request.

Note:- If Terminations are being applied to Armoured Cable, User may wish to use the 'Bolt On' Heatshrink type cylinder Gland kit. See Instructions supplied with Gland.

Glands Available

SPS 318	16-70mm ² Pilc Cable	SPS 452	35-185mm ² Picas Cable
SPS 319	95-150mm ² Pilc Cable	SPS 453	240-400mm ² Picas Cable
SPS 320	185-300mm ² Pilc Cable		

Improved Clearance/Cross Core Kit

A kit is available which converts Paper Belted Cable into a Screened Cable which enables greater clearances between Cores and allows a Core Cross if required.

SPS 946 70-400mm²



**THORNE &
DERRICK
INTERNATIONAL**

Thorne & Derrick
+44 (0) 191 410 4292
www.powerandcables.com

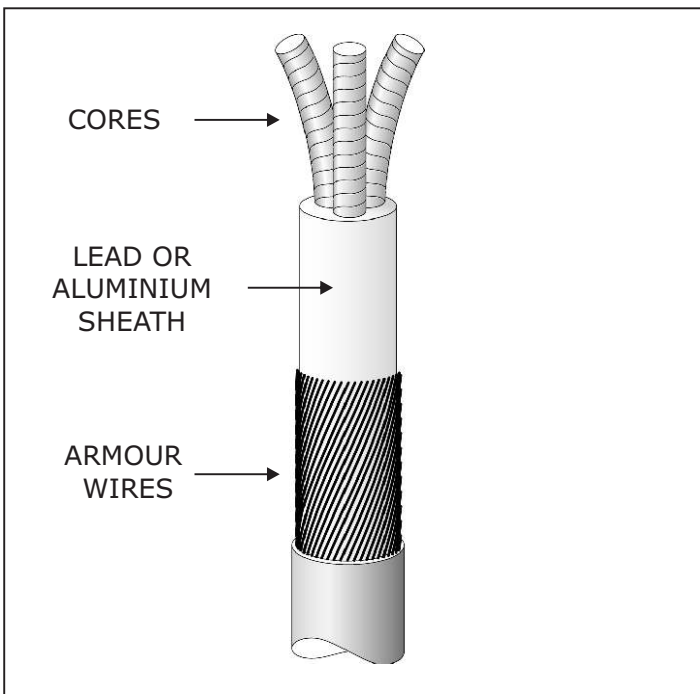

1. Installation

Prepare the Cable to the dimensions shown in Fig 1 (For dimension L see Table 1).

Expose the armour wires to 50mm for plumbed connections. De-grease and clean the Lead or Corrugated Aluminium sheath and armour wires.

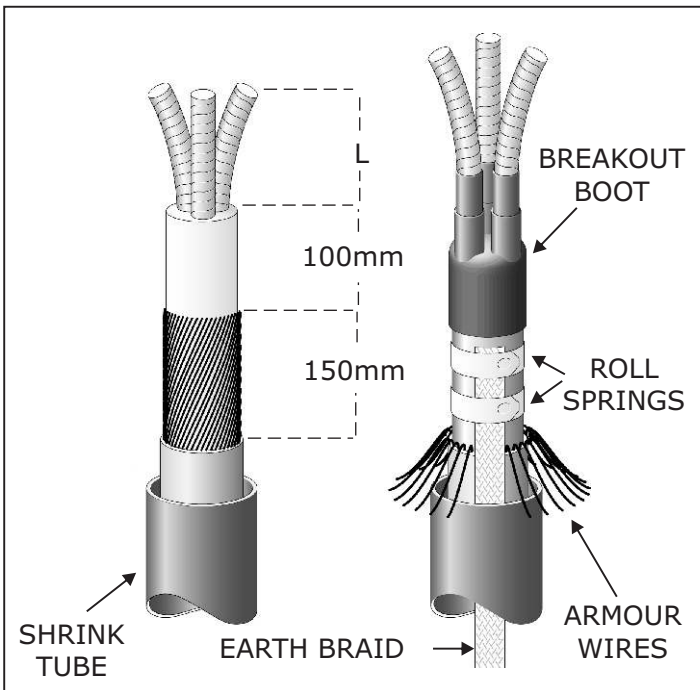

Mechanical Earthing Option

If using the Heatshrink 'Bolt On' Gland with solderless earthing, prepare Cable to dimensions shown. Note:- User may wish to adjust these dimensions so that the Breakout Boot fits down within the Gland Body.

See separate instruction sheets for Pilc and Picas Earthing using 'Bolt On' Gland with Roll Spring (Lead) and Clamp System (Picas).

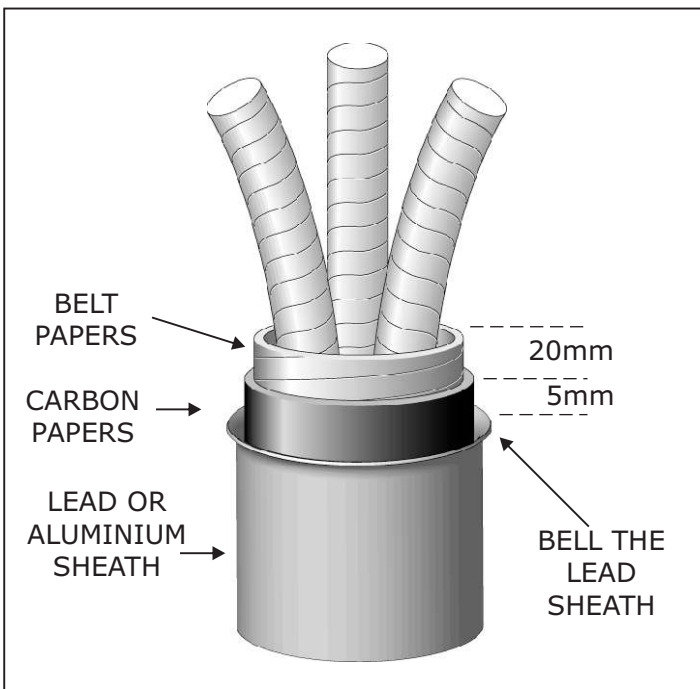

2. Belted Cable Preparation

Expose the Lead or Aluminium Sheath to a dimension of 250mm from the outer Cable Sheath.

Unwind the Black Carbon Paper and remove to a binder positioned 5mm from the Metal Sheath cut.

Using a further binder, remove the Belt Papers to 25mm from the Metal Sheath cut.

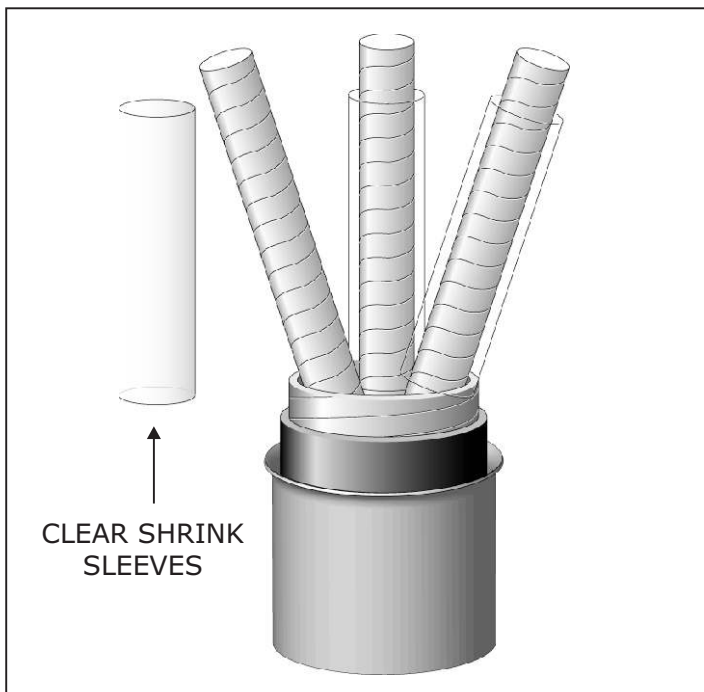

Fitting the Clear Shrink Sleeves

With a clean dry cloth, carefully remove any Grease from the Cores.

Position the Clear Shrink Sleeves over each Core approx 50mm up from the Cable Crutch. With a suitable heat source, shrink the end's of the Sleeves for about 50mm, before fully shrinking, rotate the Sleeves and push down into the Crutch.

Important: The Sleeves must be fitted as low as possible in order to protect the papers when setting the cores. Also ensure there are no air voids and the Sleeves are wrinkle free. Also note that excessive heat may dry out and damage the Paper Insulation.

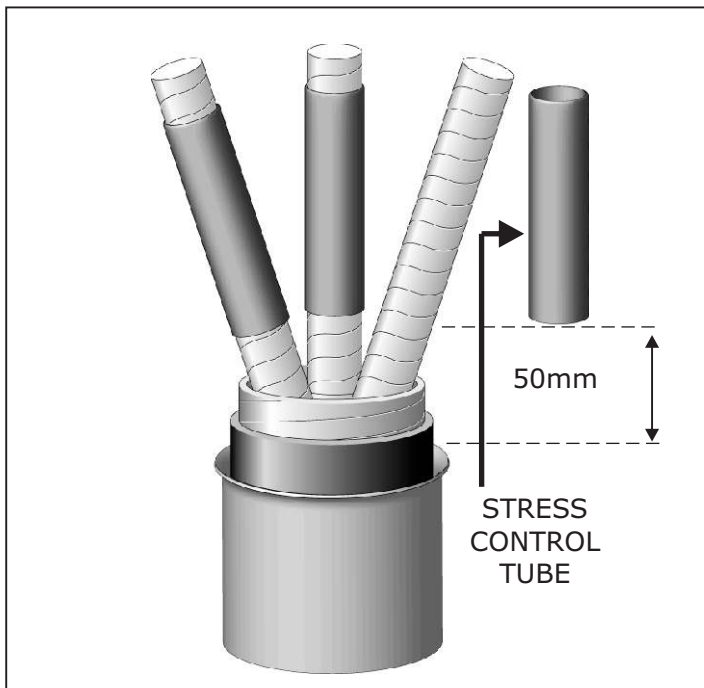

Fitting the Stress Control Tubes

Position the Stress Control Tubes onto the Cores at a distance of 50mm up from the Metal Sheath Cut.

Shrink the Tubes one at a time, starting from the bottom working upwards. Ensure that the Tubes are evenly shrunk and aligned.

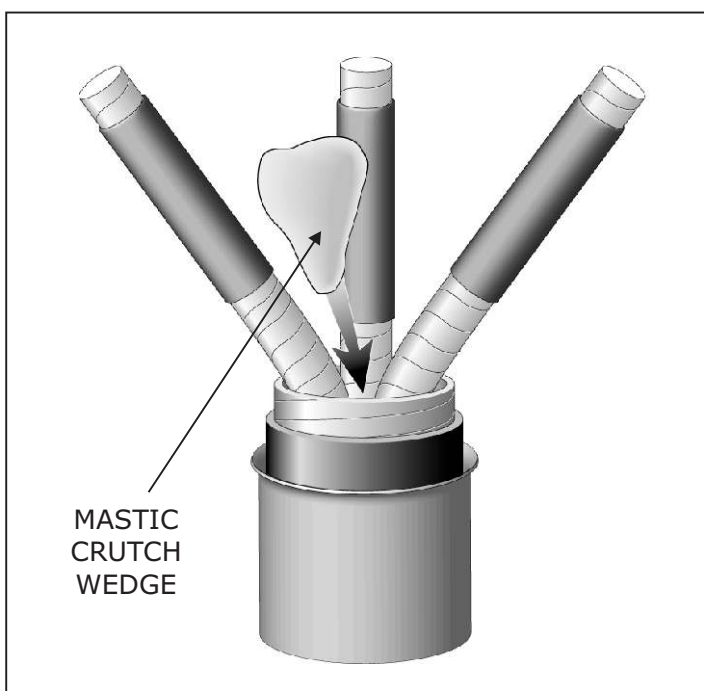

Cable Crutch Preparation

Remove the Grey Mastic Crutch Wedge from its container and insert well down into the Cable Crutch so that any Air gaps are eliminated.

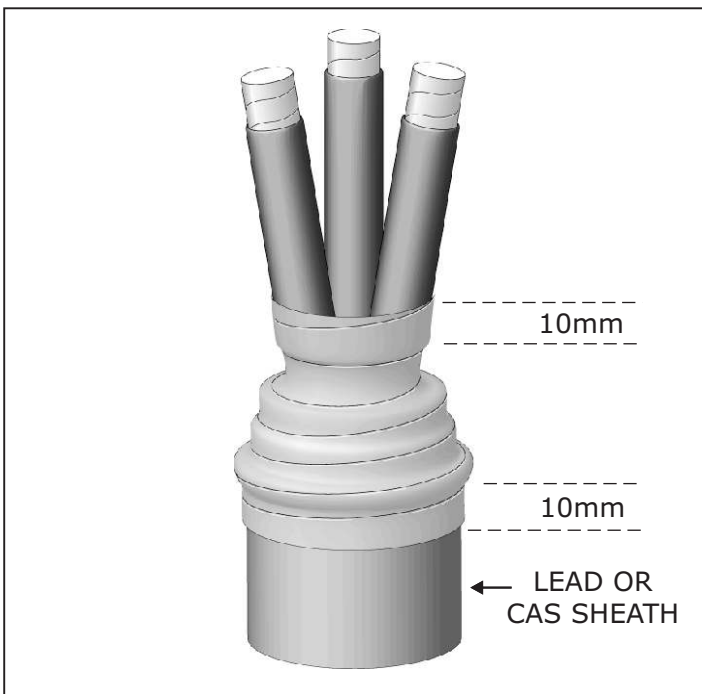

With tension, wrap the Grey Mastic Tape around the Crutch area and overlap the Stress Control Tubes and Lead or Aluminium Sheath by approx 10mm.

Note:- Ensure that the space between the Bell of the Lead Sheath and the entire area between the Cores is fully covered by the Mastic tape to eliminate Air Voids.

With a suitable solvent, clean the Metal Sheath before proceeding.

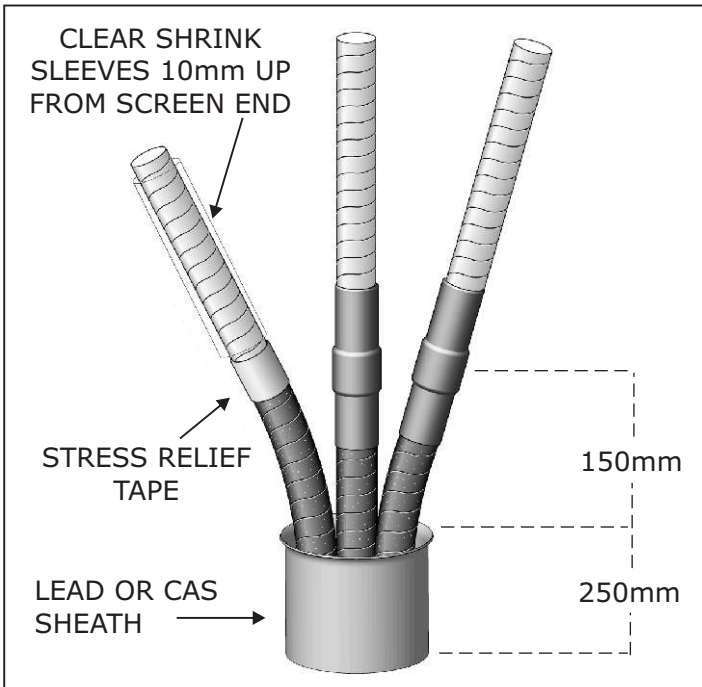

3. Screened Cable Preparation

Leave the Metal Sheath exposed by 250mm from the outer Cable Sheath. Remove any fillers.

After positioning a suitable Binder 150mm up from the Metal Sheath, remove the Screen Papers neatly at this point and discard the Binder.

With a clean dry cloth, remove any Grease from the Cores. Position the Clear Shrink Sleeves at a distance of 10mm above the Screen ends and shrink into position starting from the bottom upwards. Ensure Sleeves are free from Air Voids and are Wrinkle free.

Apply Stress Tape

Remove the release paper and whilst stretching, wrap the Yellow Stress Relief Tape around the end of each Core Screen.

Overlap the Tape onto the Screened Papers by 20mm and the Clear Shrink Sleeves by 10mm. Leave a thin edge on the last turn.

Note: it may not be necessary to use all of the tape supplied.

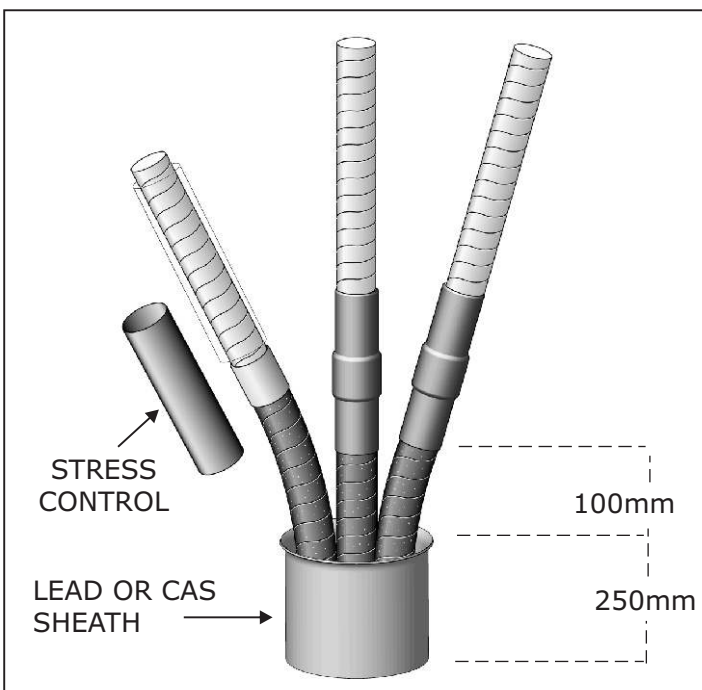

Fitting the Stress Control Tubes

Position the Stress Control Tubes at a distance of 100mm above the Metal Sheath cut. Shrink evenly from the bottom upwards so that the Tubes overlap onto both the Screen and paper Insulation.

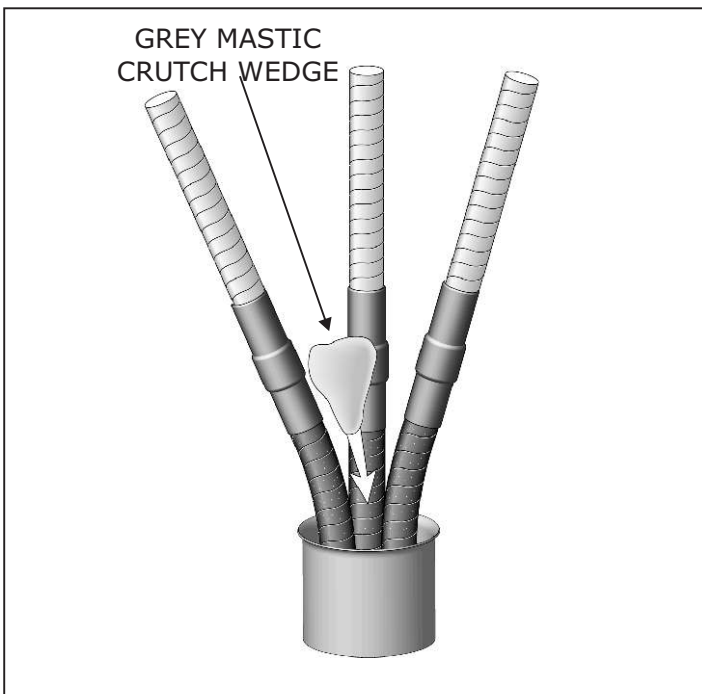

Cable Crutch Preparation

Remove the Grey Mastic Crutch Wedge from its packaging and insert it well down into the Cable Crutch so that any Air gaps are eliminated.

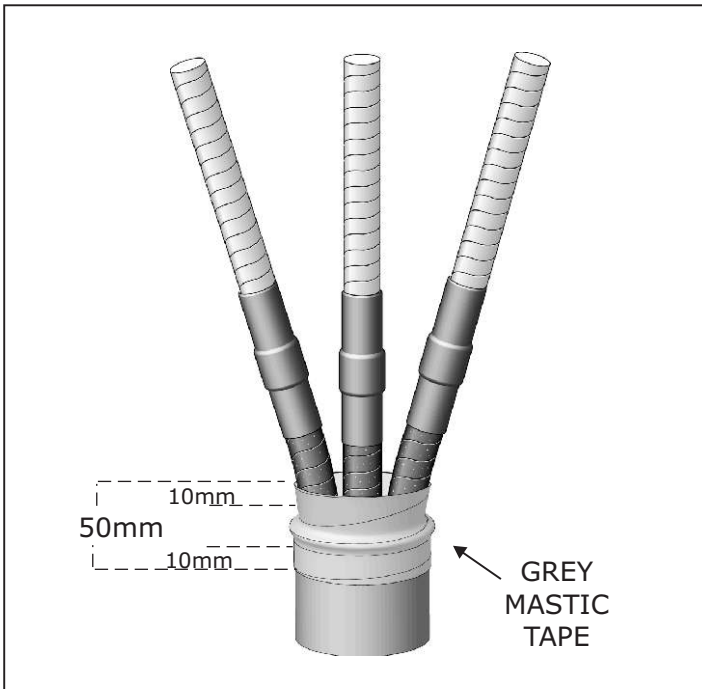

Clean the Metal Sheath. With tension, wrap the Grey Mastic Tape around the Cable Crutch area and extend onto the Metalised Screen Papers and Metal Sheath by a minimum of 10mm

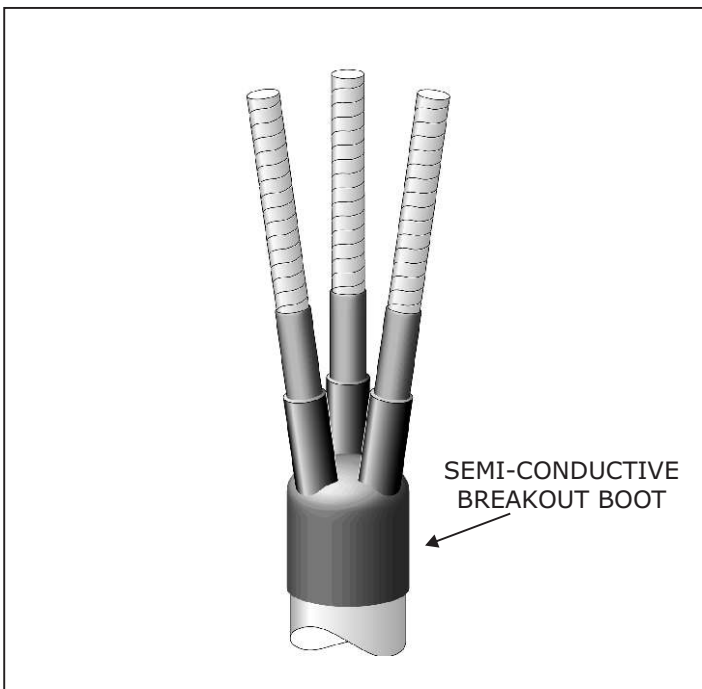

4. General Cable Preparation

Installing the Breakout Boot

Slide the 3 Leg Semi-Conductive Breakout Boot down the Cores and press firmly down into the Crutch.

On Belted Cable, the Legs of the Boot should be in contact with the Stress Control Tubes and the Skirt should cover the Grey Mastic Tape and make contact with the Lead or Aluminium Sheath.

Shrink the Boot from the centre to one end at a time. The Boot may need to be held in place during installation.

Note:- On Screened Cable the Boot need not be in contact with the Stress Control Tubes. See Supplement Instruction for further advice.

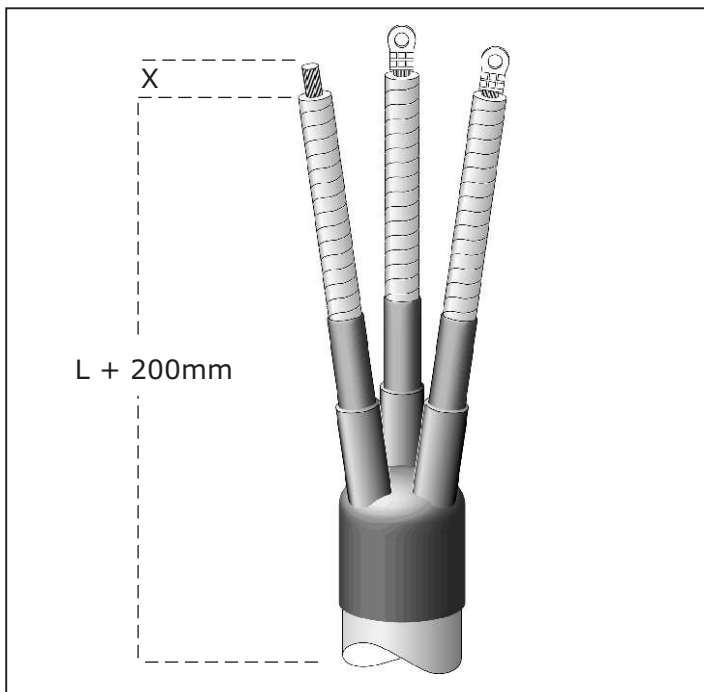

5. Installing Cable Lugs

Allowing for dimension X (Lug Barrel + 5mm), cut the Cores to suit the fixing point on the equipment being used.

Measure a distance of X (See Table 1) back from the end of each Core and remove Insulation.

With a suitable tool, install Cable Lugs ensuring that any sharp points are removed.

Note:- Where Mechanical Connectors are to be used, user should check that the Core Tubes are able to slide over prior to fitting.

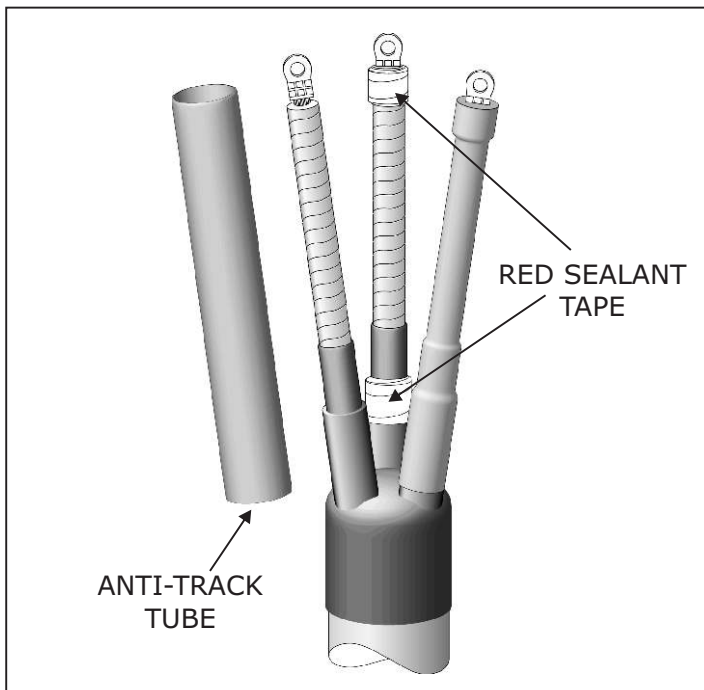

6. Installing Anti-Track Tube

Preheat each Cable Lug and wrap two layers of Red Sealant Tape over the Lug Barrel extending onto the Insulation by approx 10mm. Add more tape if diameter of lug barrel needs building up.

Also apply a turn of Red Sealant around the tops of the Breakout Boot fingers.

Position the Anti-Track Core Tubes so that they cover the Fingers of the Breakout Boot and the Barrels of the Lugs.

Shrink the Tubes starting from the bottom towards the top. Keep the flame on the move to ensure an even wall thickness and that the Tubes are wrinkle free. Allow to cool to hand hot and trim at the Lug end with a sharp knife if necessary.

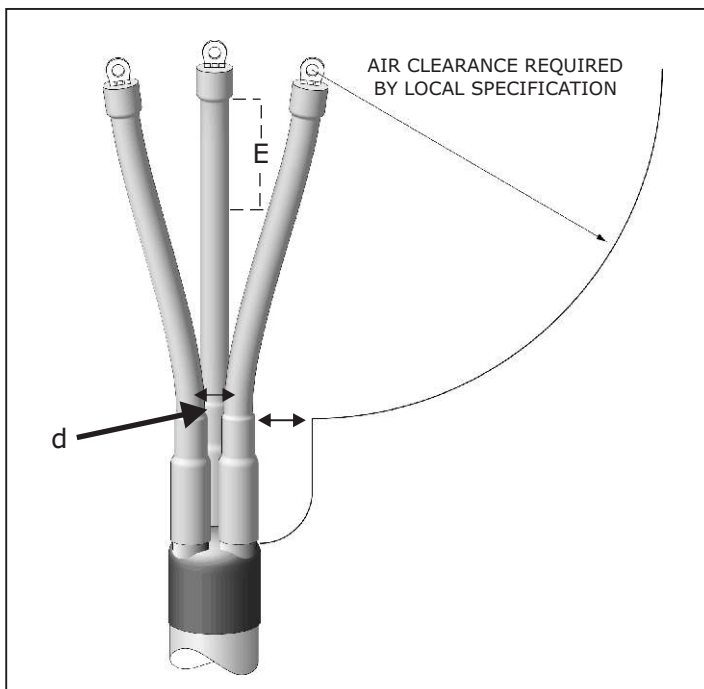

Indoor Termination Requirements

DISTANCE (d) PHASE/PHASE & PHASE/GROUND	TOP OF STRESS TUBE TO LUG BARREL	
VOLTAGE	d (mm)	E
7.2kV	15mm	30mm
12kV	20mm	50mm
17.5kV	20mm	75mm
24kV	25mm	95mm
36kV	40mm	250mm

Table 2

Note:- Bushing protection boots will be required for the majority of installations.

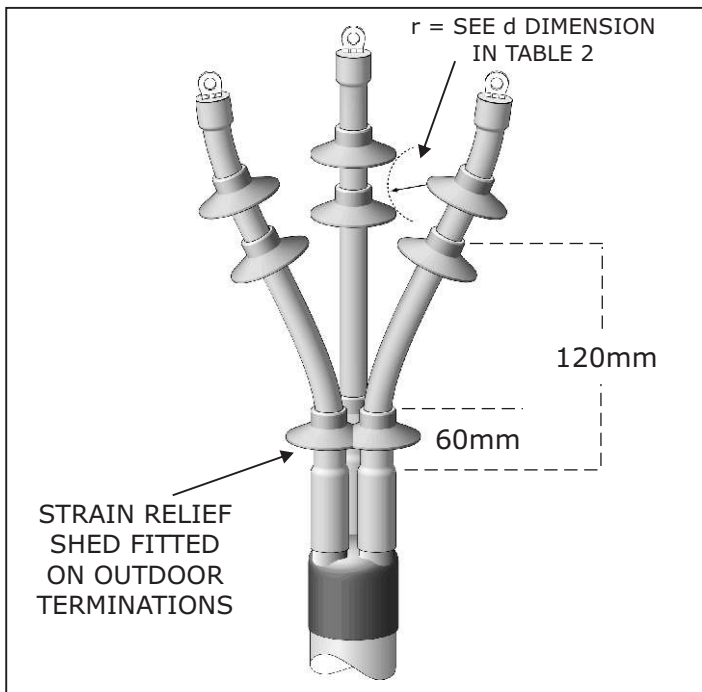

7. Installation Of Rain Sheds

A Strain Relief Shed is required for Outdoor Terminations. This should be fitted first by positioning it as low down as possible but above the end of the Breakout Fingers (Approx 60mm).

Continue to install the appropriate number of Rain Sheds in accordance with the details shown in Table 3.

VOLTAGE	NUMBER OF SHEDS PER PHASE	
	INDOOR	OUTDOOR
7.2kV	-	1
12kV	-	1
17.5kV	-	1
24kV	1	2
36kV	1	3

Table 3

All subsequent sheds should be fitted at a distance of 80mm from edge to edge.

Note:- It is advisable not to position rain sheds at the top of stress control tubes, re-position if necessary.

If a termination is to be mounted for connection above the equipment i.e in the reverse position, sheds should be installed through 180° as shown.

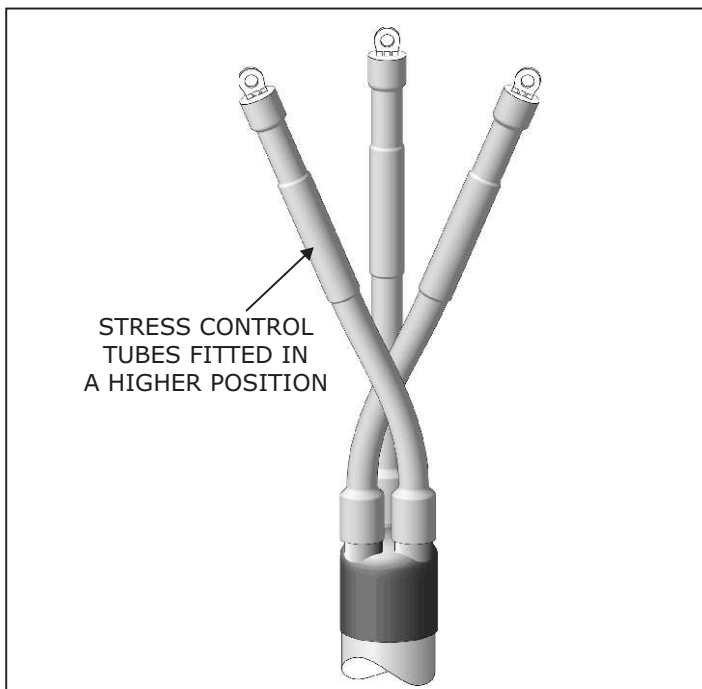
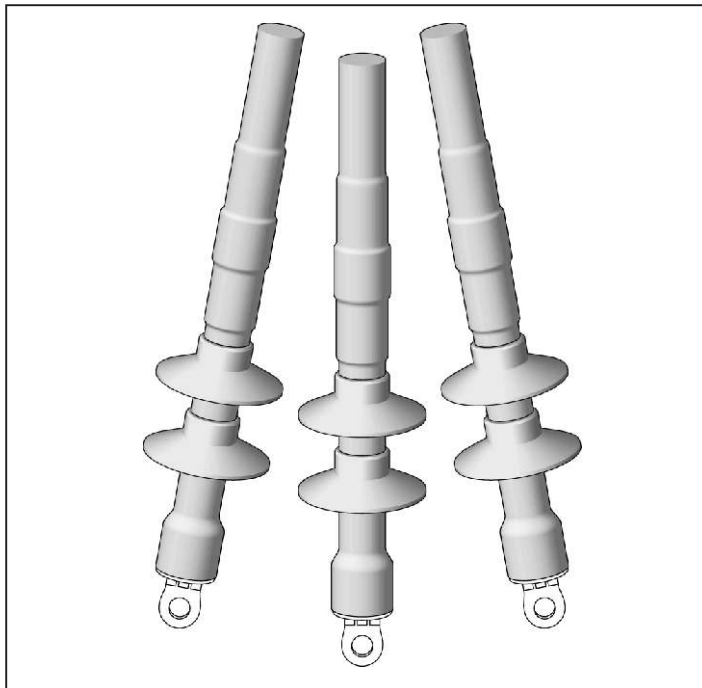

7. Core Crossing

Screened Cable

If the Cores on a Paper Screened Cable have to be crossed, ensure that the cross takes place within the screened area below the Stress Control Tubes.

Belted Cable

Core crossing on Belted construction is not recommended unless the minimum clearances are achieved (See Table 2).

Note:- Core Crossing/Improved Clearance kits utilising Heatshrink Conductive Tubings can be supplied if requested.