



Shrink Polymer Systems

Cable Installation Materials – 24 volts to 36 kV

Installation Instruction Heat Shrink Termination For Single Core Polymeric Cables 7.2kV to 36kV

* PLEASE READ INSTRUCTIONS THOROUGHLY BEFORE PROCEEDING *

INDOOR



OUTDOOR



Use free software on your smart phone to scan the QR code below to watch an installation video on single core xlpe medium voltage terminations



ISSUE DATE: 14.12.15



**THORNE &
DERRICK**
INTERNATIONAL

Thorne & Derrick
+44 (0) 191 410 4292
www.powerandcables.com

- **General Fitting Instructions**
 - **It is highly recommended that a tool suitable for the removal of the semi-conductive screen is used to provide a reliable discharge free termination screen point**
 - **Use a propane gas torch with a soft flame**
 - **Avoid a pencil like blue flame which is caused by unregulated supply**
 - **Keep the flame on the move to ensure even shrinkage of all the materials and also helps to reduce scorching**
 - **Ensure that all components are kept clean and grease free during installation**
 - **Allow to cool before applying any mechanical strain**

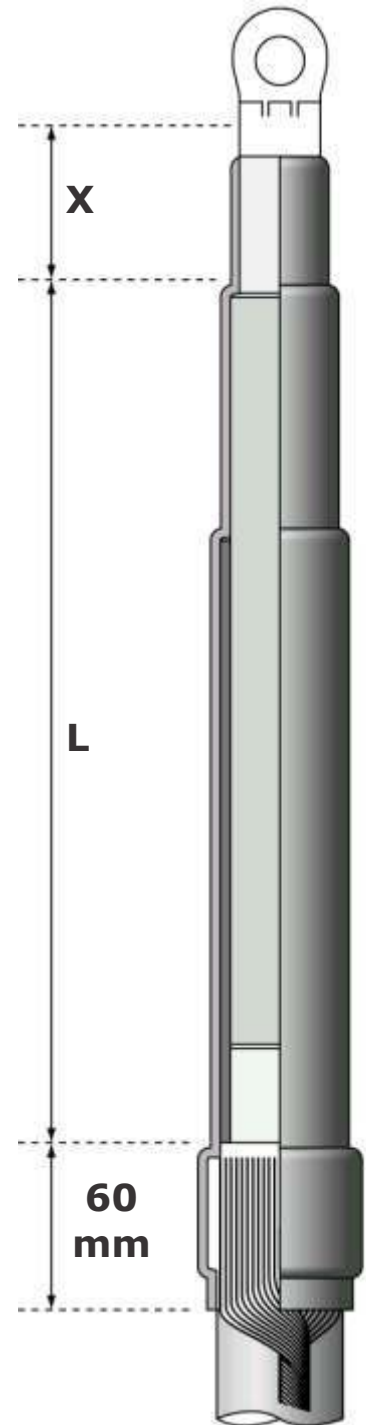

Fig1

Remove Outer Cable Sheath:

VOLTAGE	INDOOR L	OUTDOOR L	X
7.2kV	150mm	200mm	LENGTH OF LUG BARREL + 10%
12kV	190mm	270mm	
17.5kV	250mm	300mm	
24kV	310mm	460mm	
36kV	510mm	600mm	

Table 1

Single Core Armoured Cables

If the cable is armoured, bonding of the armours must be completed

using the appropriate armour earthing kit.

A) For indoor terminations (cable end box) - Order bolt on aluminium earth gland Ref: SPS 560*

B) For outdoor terminations (pole top) - Please advise conductor and voltage rating.

* SPS 560 size range = 50-630mm² 7.2-36kV

Gland kits for triplex cables are also available

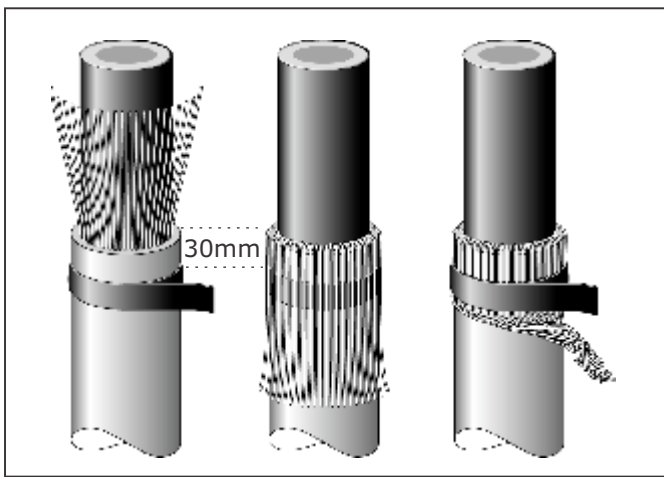

Fig 2

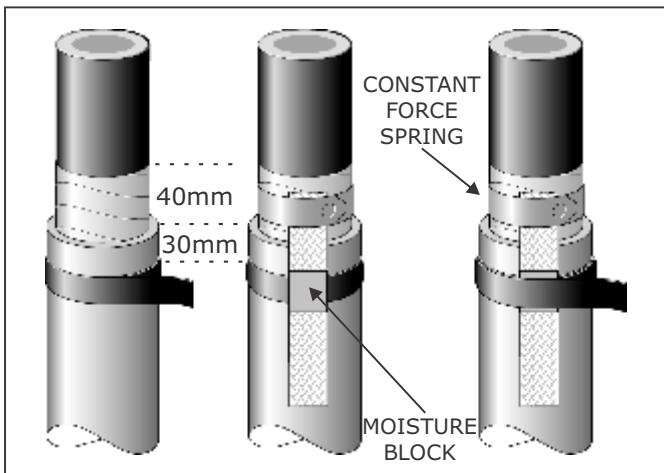

Fig 3

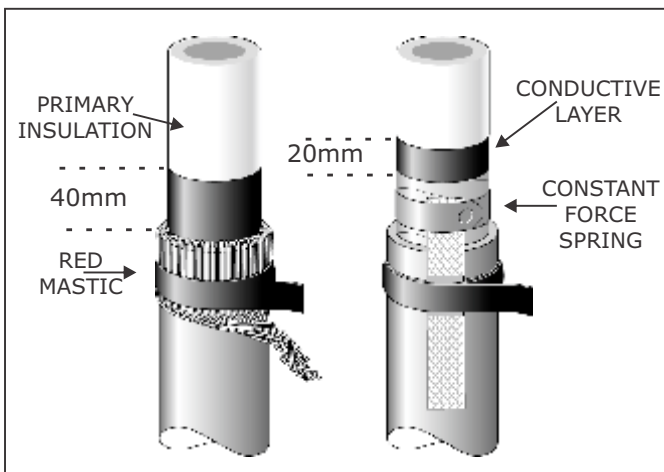

Fig 4

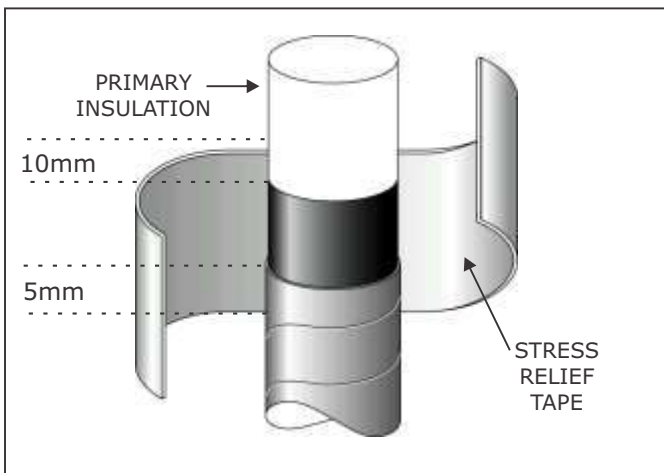

Fig 5

1. Installation

Remove the outer cable sheath to the dimensions $L + X$ given in Table 1.

Remove any fillers before cleaning and de-greasing the cable sheath below.

2. Screen Treatment

Copper Wire Screen

Apply one turn of the red mastic sealant tape at a point 30mm below the sheath cut (Fig 2).

Bend back the copper wires and press them into the tape. Apply one more turn of red mastic tape over this point. The wires should be twisted together and bonded to a suitable earth point.

Copper Tape Screen

Apply one turn of the red mastic tape at a point 30mm below the sheath cut (Fig 3).

Remove the copper tape screens to a point 40mm above the cable sheath cut as shown opposite in Fig 3.

Position a copper earth braid onto the copper screen and secure with a constant force roll spring. Ensure the moisture block in the braid is bedded into the red mastic and apply one more turn of tape over this point. Secure the end of the braid to a suitable earth point.

Note:- A full range of solderless earth bonding kits are available for all voltages and conductor sizes.

3. Conductive Layer Treatment

Extruded Conductive Layer

Carefully remove the conductive screen layer using an approved tool. Ensure all traces have been removed. User may wish to polish the cores with 240 grade al oxide paper.

Stretch and apply the yellow stress relief tape around the screen end extending onto the insulation by 10mm and onto the conductive screen by 20mm. If copper tape screen is present, extend tape by 5mm as shown in Fig 5. **Note:** it may not be necessary to apply all of the tape.

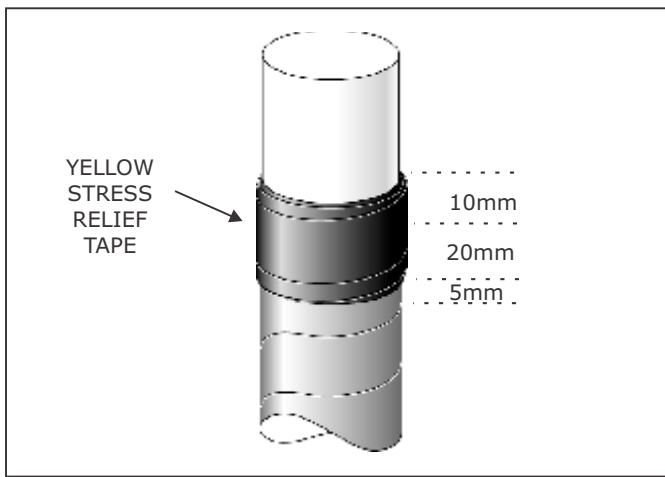

Fig 6

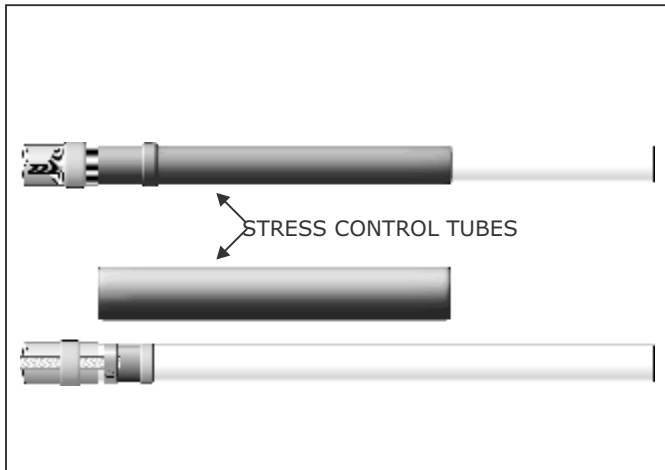

Fig 7

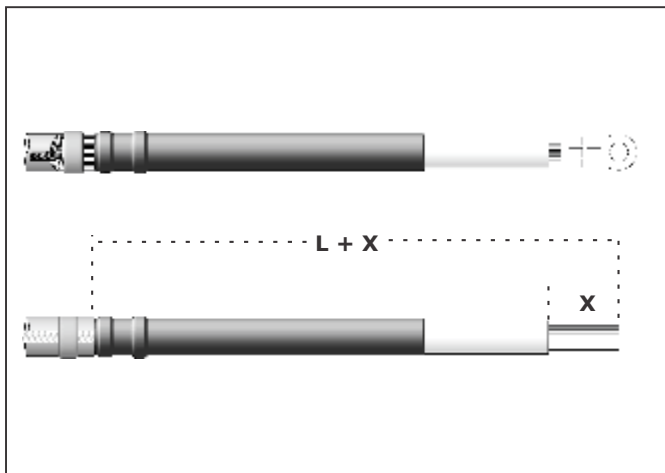

Fig 8

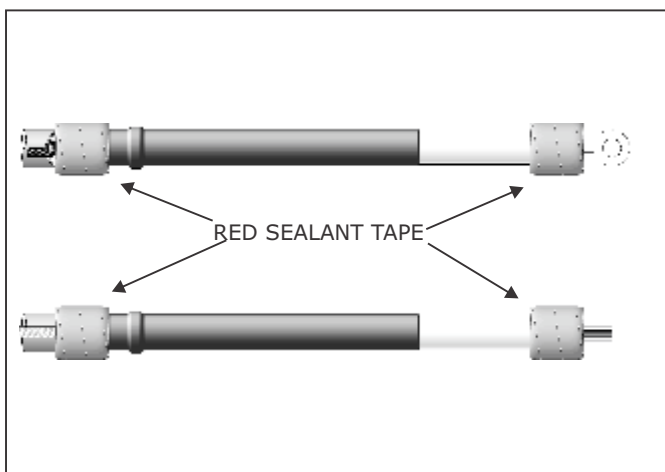

Fig 9

Soluble Conductive Layer

Cover the conductive screen with non adhesive tape for 40mm on wire screened cables and 20mm on copper tape screened cables (see Fig 4).

Remove the layer after this point with a suitable solvent until totally clean. Remember to remove the tape when finished.

4. Apply Stress Relief Tape

Stretch and apply the yellow stress relief tape around the screen end extending onto the insulation by 10mm and onto the conductive screen by 20mm. If copper tape screen is present, extend tape by 5mm as shown in Fig 6. **Note:** it may not be necessary to apply all of the tape.

5. Stress Control Tubes

Position the stress control tubes so that they cover the earth connection point and the conductive screen end. However do not extend past this point onto the outer cable sheath.

Shrink the tubes one at a time starting from the bottom. Ensure the tubes are wrinkle free and have an even wall thickness.

6. Installing Cable Lugs

The cable should be cut to dimension $L+X$ as given in Table 1. Remove the insulation at X and install the lug using the appropriate method.

Preheat each lug and wrap two layers of red sealant tape over the lug barrel and extend onto the insulation by approx 10mm. Ensure the tape is applied as shown. **Important:-** use more tape to build up the diameter to ensure tube recovers upon it and creates a moisture seal.

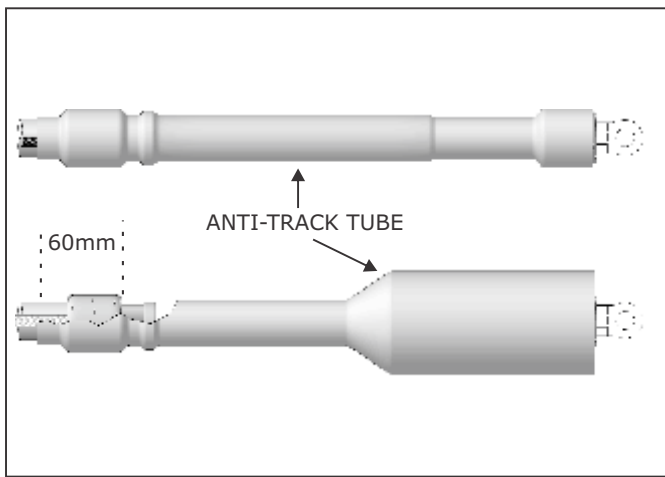

Fig 10

VOLTAGE	NUMBER OF SHEDS PER PHASE	
	INDOOR	OUTDOOR
7.2kV	-	1
12kV	-	2
17.5kV	-	2
24kV	-	3
36kV	1	4

Table 2

7. Installing Anti-Track Tube

Position the anti-track tubes so that they overlap the earth connection point and outer cable sheath by 60mm as shown in Fig 10.

Shrink the tubes starting from the bottom towards the top. Keep the flame on the move to ensure an even wall thickness. User may trim the tubes at the lug end with a sharp knife if necessary.

8. Indoor Terminations

Anti-track rain sheds are not required on indoor terminations rated between 7.2 and 24kV. One shed per phase is required on 36kV types (see Table 2).

Clearance Dimensions

Minimum clearances should be observed for phase to phase and phase to ground from top of stress tubes (see Table 3).

VOLTAGE (kV)	7.2	12	17.5	24	36
DISTANCE (mm)	15	20	25	40	50

Table 3

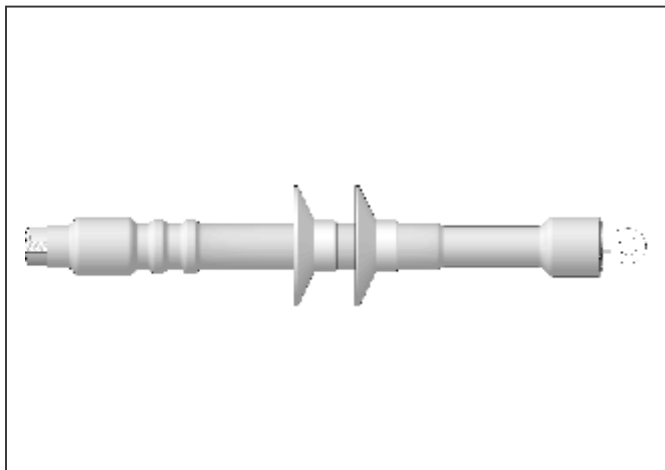

Fig 11

9. Outdoor Terminations

Anti-track sheds should be fitted starting from the bottom up as per the dimensions given in Fig 12.

The number of sheds required depends on the system voltage (see Table 2).

Positioning of Sheds

The first shed should be fitted at a distance of 200mm from the lower edge of the anti-track tube to the edge of the shed. All subsequent sheds should be fitted at a distance of 80mm from edge to edge.

Note:- It is advisable not to position sheds at the top of the stress control tubes. Re-position if necessary.

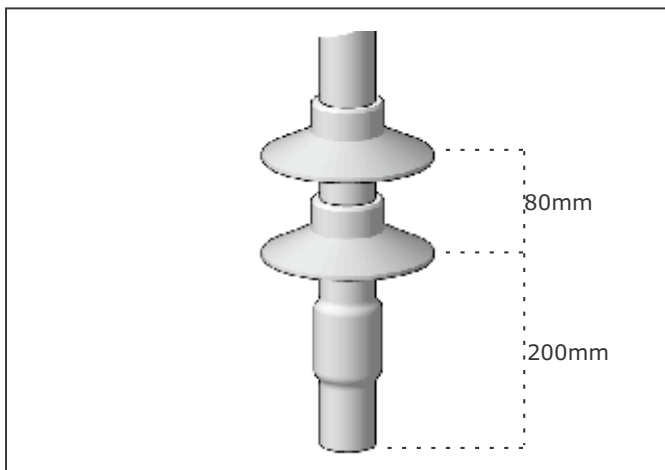

Fig 12

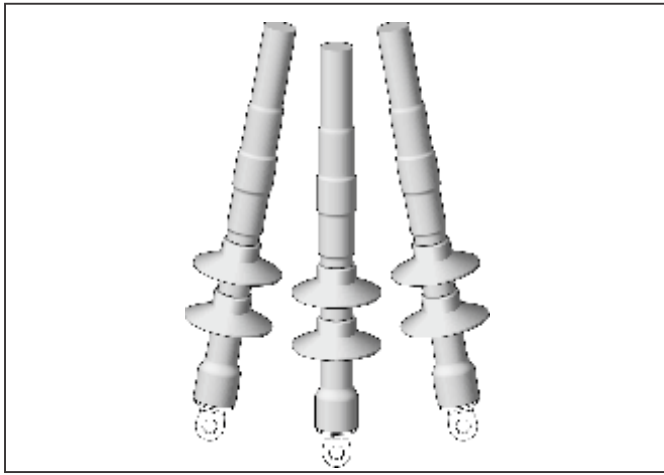

Fig 13

Reverse Connection

If a termination is to be mounted for connection above the equipment i.e in the reverse position, sheds should be installed through 180 degrees as shown in Fig 13.

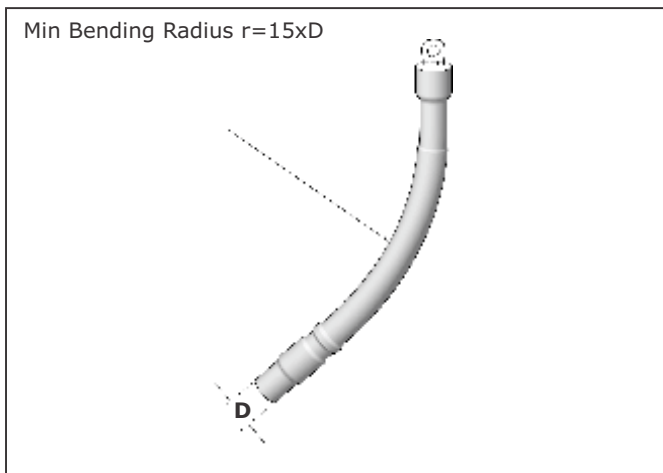

Fig 14

10. Cable Bending Radius

If required the cable can be heated to approximately 70°C to enable a bend to be introduced. See Fig 14 showing the bending radius.

Important: user/circuit designer should determine whether or not special earthing requirements are needed to reduce the possible effects of circulating currents in armoured cables. The decision to single point earth/solid point earth or install cross bonding kits needs to be considered once length of run, loading and positioning of cables is known.



THORNE &
DERRICK
INTERNATIONAL

Thorne & Derrick
+44 (0) 191 410 4292
www.powerandcables.com