

CAUTION : Read instructions thoroughly and completely prior to beginning installation.









Installation instructions for separable tee connector - type C interface



**(K),(M)440TB/G**  
Up to 36 kV

Only to be used on copper tape screened cable with extruded semi-conductive screen and stranded circular conductors of copper or aluminium.

**Required components for the connector installation :**

 3 x Tee connector housing P440BT/G	 3 x Cable reducer 611CA-W	 3 x Clamping screw - 400TCS	 3 x Conductor contact - TBC-X or TMBC-X + Installation instructions
 3 x Basic insulating plug + cap - 400BIPA	 3 x Field control mastic MFC	 Roll adhesive tape	 Silicone grease + wipers Gloves
3 x Earthing kit : - earth braid - tinned copper wire - watersealing mastic, type MWS, used for outdoor applications		 Installation instructions + crimp chart	

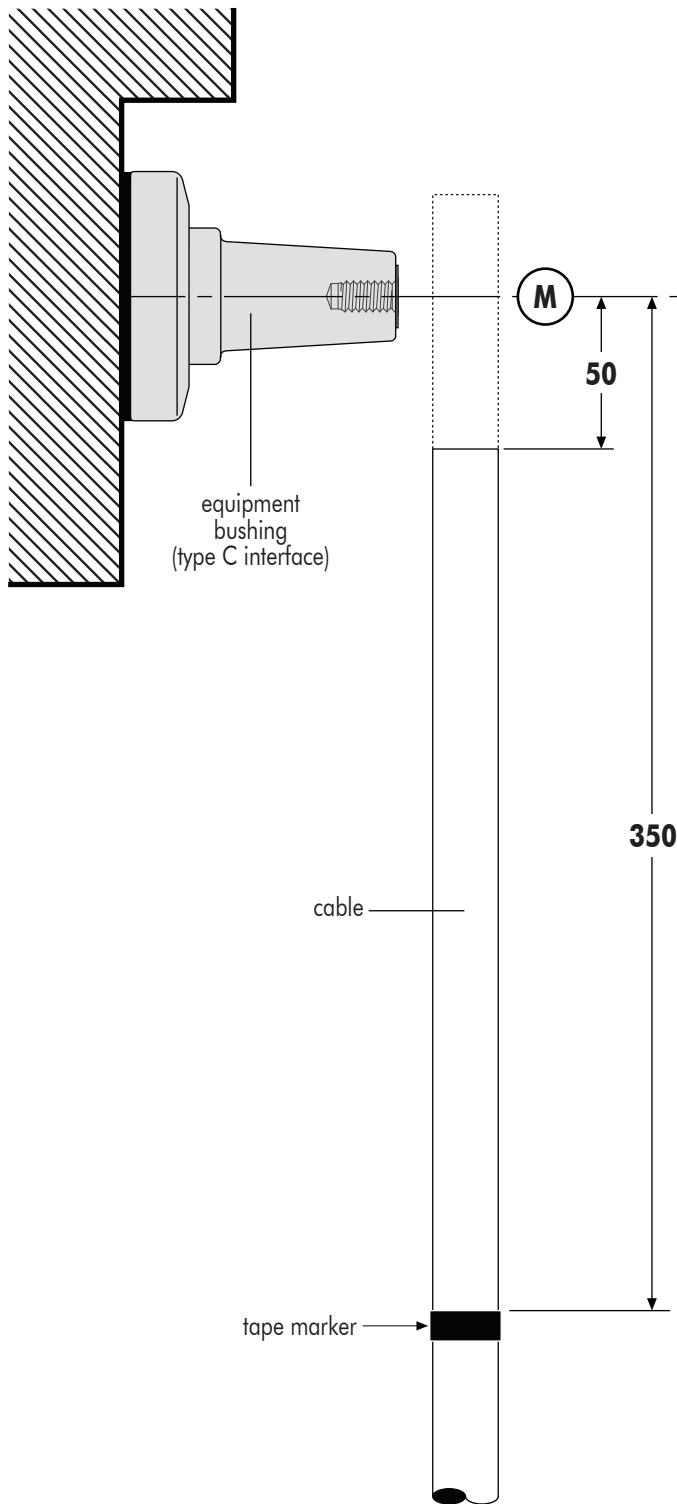

- 1 Train the cable into the approximate finished position next to the equipment bushing.
- 2 Apply a tape marker on the outer sheath **350** mm from the centre line «M» of the bushing.
- 3 Cut the cable to length a distance of **50** mm from the centre line of the bushing.

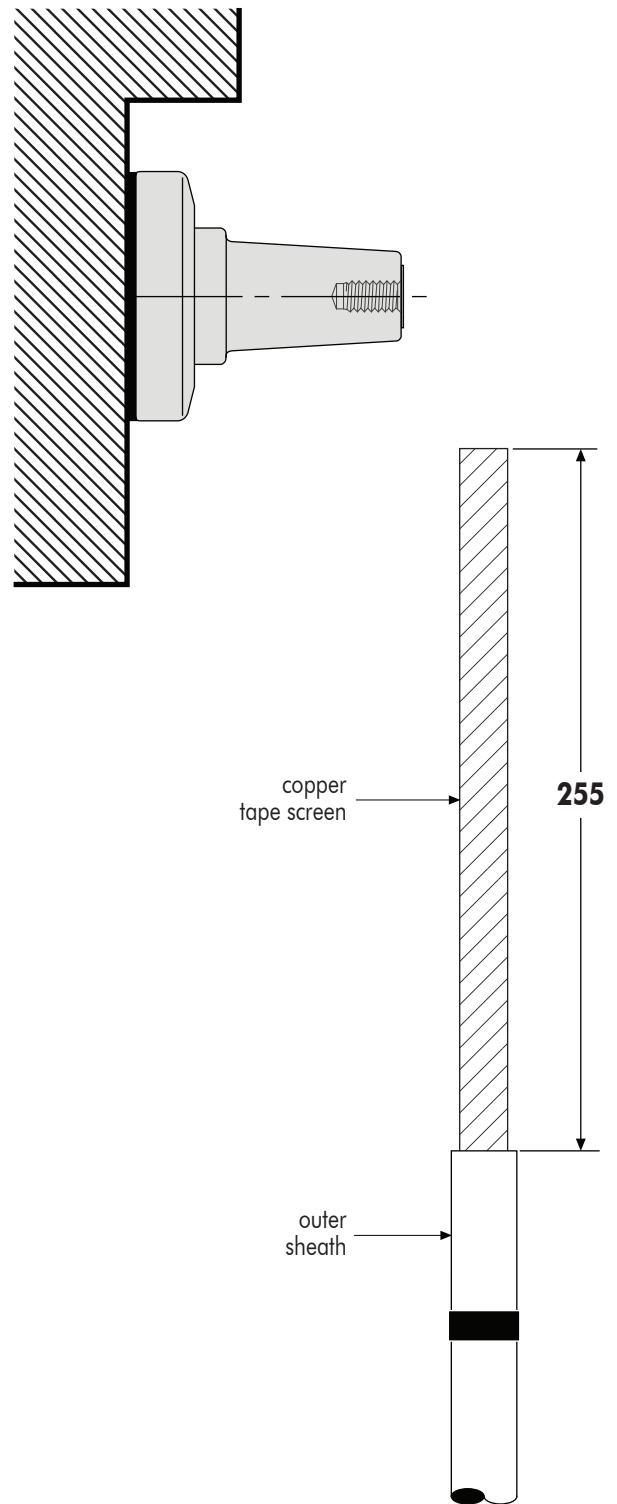

- 4 Remove the outer sheath for a distance of **255** mm. **Do not cut or nick the copper screen.**

## CABLE PREPARATION

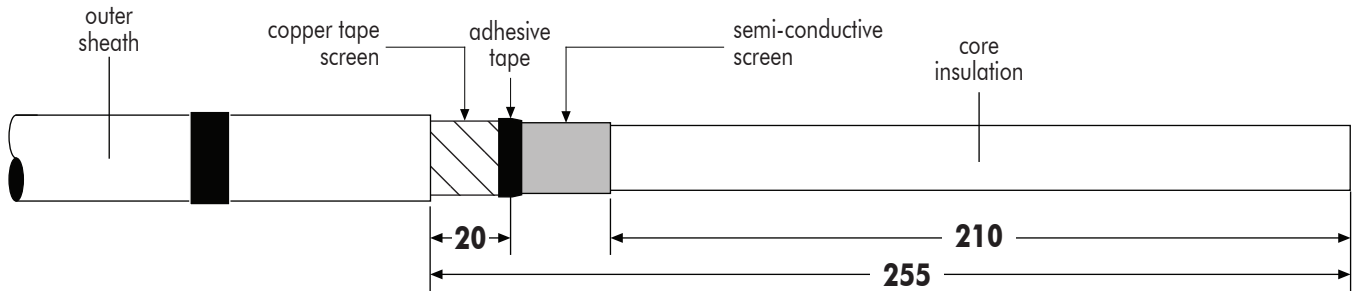

- 1 Check distance of **255** mm.
- 2 Remove the copper tape screen to a point **20** mm from the outer sheath and secure with a wrap of vinyl tape.
- 3 Remove the extruded conductive screen to a point **210** mm from the cable end.

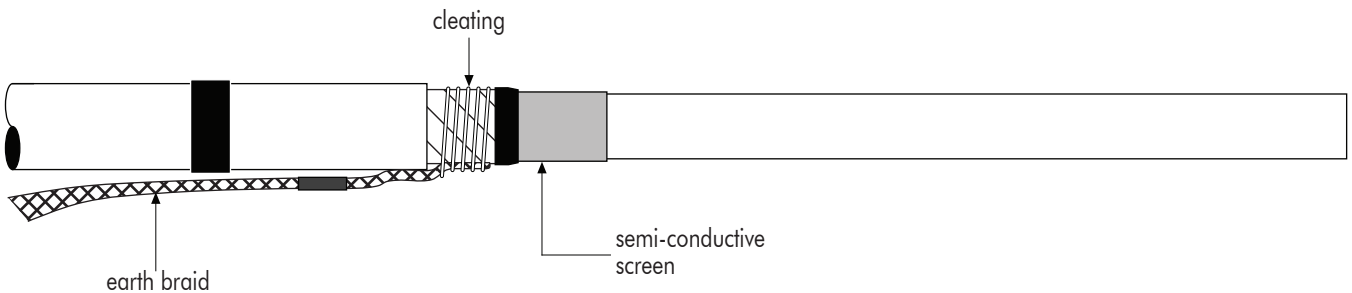

- 4 Using the tinned copper wire, cleat the braid to the copper tape screen.
- 5 **Remove any traces of conductive residue from the core insulation.**  
Always wipe towards the outer sheath.

## OUTDOOR APPLICATIONS

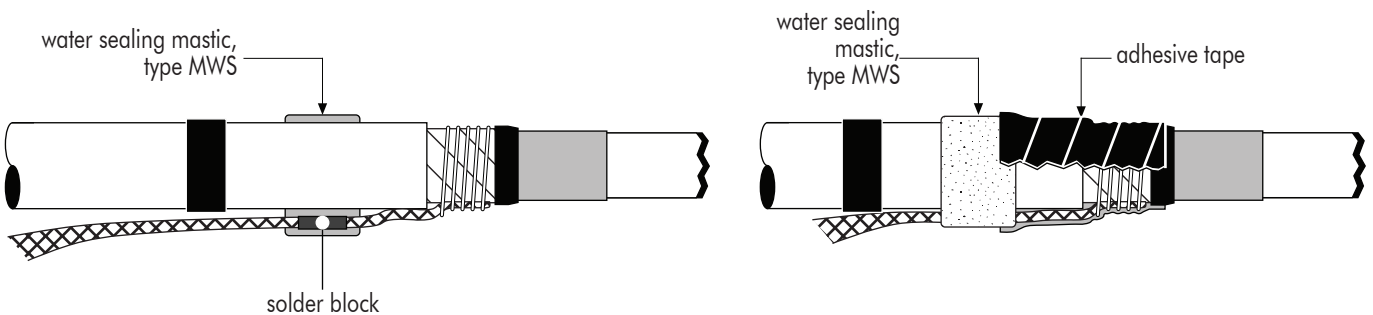

- 1 Apply one turn of water sealing mastic, type MWS, on the outer sheath, slightly stretched, underneath the solder block on the braid. Fold back the braid and without cutting the mastic, apply a second turn of the mastic around outer sheath and braid.
- 2 In order to facilitate the installation of the cable reducer, apply one layer of adhesive tape. Start taping on the cleating of the braid and continue, up to a point **5** mm on the mastic.
- 3 **Check cleanliness of the core insulation.**

## REMOVAL OF THE CORE INSULATION

### A. Compression type contacts (Type TBC-X)

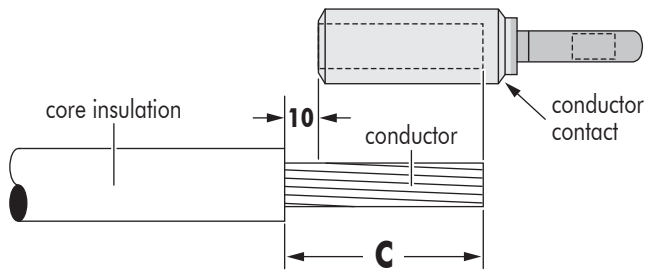

### B. Mechanical type contacts (Type TMBC-X)

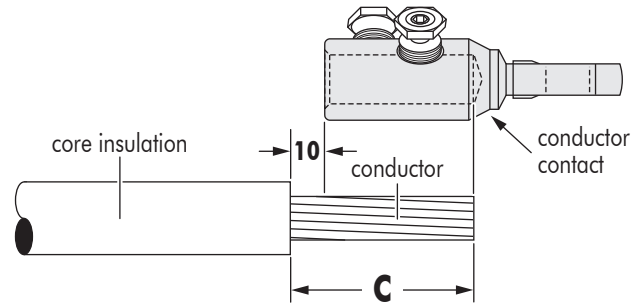

- 1 A. For compression type contacts :** remove the core insulation from the conductor for a distance « **C** » mm (**C** = depth of contact bore + **10** mm).
- 1 B. For mechanical type contacts :** remove the core insulation from the conductor for a distance « **C** » mm (**C** = depth of contact bore + **10** mm).

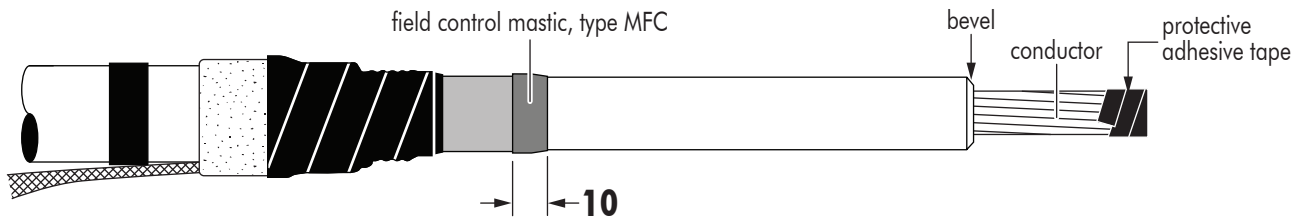

- 2** Slightly bevel the edge of the core insulation (max 2 mm). **Do not sharpen in cone-shape.**
- 3 Thoroughly clean core insulation.** Always wipe towards the screen wires.
- 4** As a protection, wrap a few turns of adhesive tape around the conductor end.
- 5** Remove the field control mastic strip, type MFC, from the coated paper. Apply the mastic on the cutback edge of the semi-conductive screen, covering approximately **5** mm of the extruded semi-conductive screen and **5** mm of the core insulation. Push the mastic in place while stretching it progressively until both ends overlap and tear-off the excess mastic. Using the coated side of the paper, squeeze the mastic tightly in place on the step of the semi-conductive screen.

## INSTALLATION OF THE CABLE REDUCER

### Indoor applications

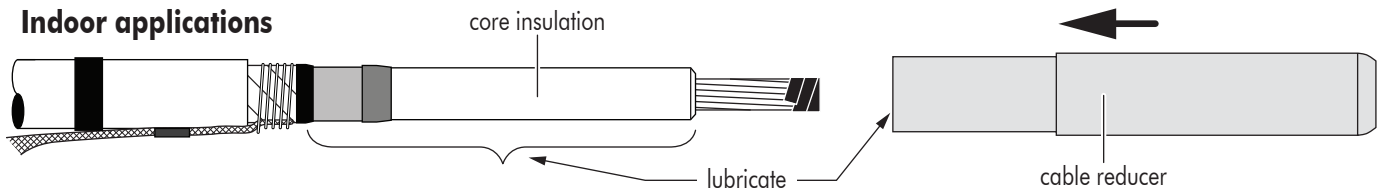

### Outdoor applications

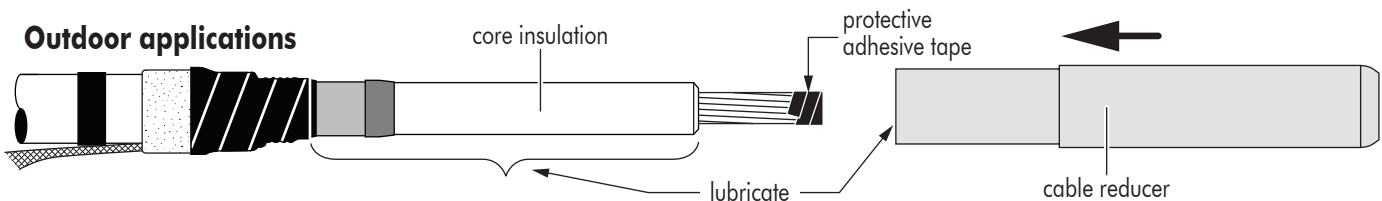

- 1** Lubricate\* the indicated area : core insulation, mastic, semi-conductive screen and inner surface of the reducer.
- 2** Slide the reducer down the cable.
- 3** Remove the protective adhesive tape from the conductor.

\* USE ONLY THE SILICONE LUBRICANT SUPPLIED

## CRIMPING/TIGHTENING OF THE CONTACT

# A

### Compression type contacts (Type TBC-X)

Please refer to the crimp chart supplied with the contact.

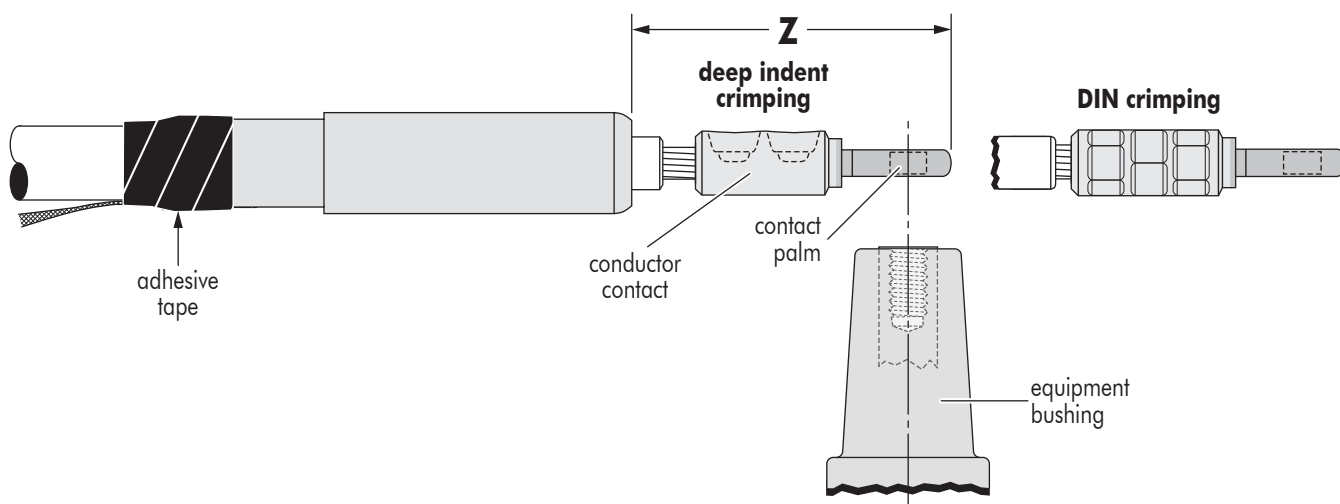

- 1 For aluminium conductors : before installing the conductor contact, wire brush the conductor.
- 2 Fit the contact on to the conductor.
- 3 Position the crimp contact taking care that the contact hole aligns with the bushing hole. **The contact must align with the bushing in order to avoid any undue pressure on the bushing or the connector.**
- 4 Prior to crimping distance « Z » must be between **155** and **165** mm.
- 5 Crimp the contact. Please refer to the crimp chart for crimp sequence.
- 6 After crimping distance « Z » must be between **160** and **170** mm.  
If necessary, adjust the position of the cable reducer until distance « Z » is within the tolerance range.  
Using adhesive tape, secure the cable reducer.
- 7 **Remove any burrs left after crimping and wipe-off excess inhibitor.**

## B

## Mechanical type contacts (Type TMBC-X)

## Before tightening

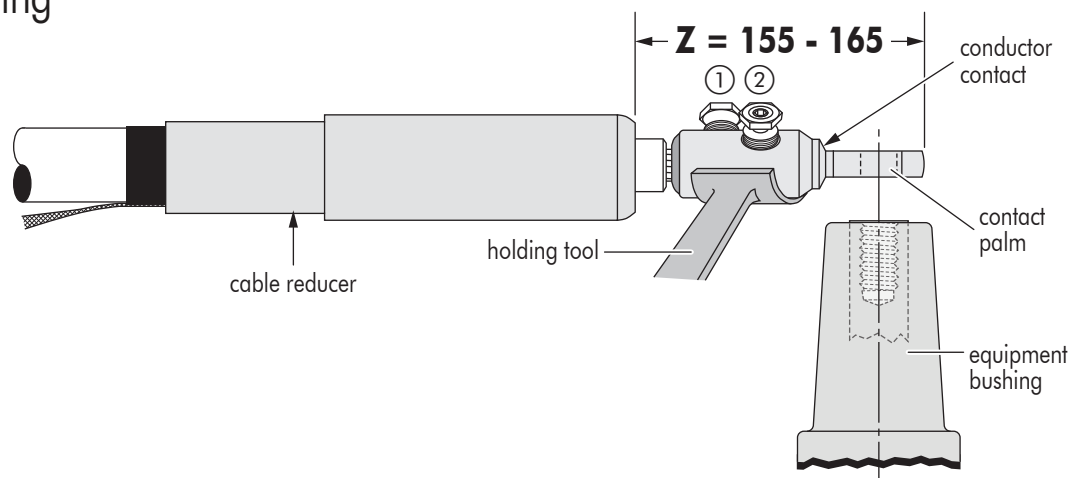

- 1 For aluminium conductors : before installing the conductor contact, wire brush the conductor.
- 2 Insert, if necessary, the centre ring into the contact barrel according to the table in the contact installation instruction.
- 3 Position the contact so that the contact hole aligns with the bushing hole. **The contact must align with the bushing in order to avoid any undue pressure on the bushing or the connector.**
- 4 Before tightening, distance «  $Z$  » must be between **155** and **165** mm.
- 5 Tighten the contact. Please refer to the installation instruction included with the contact.

## After tightening

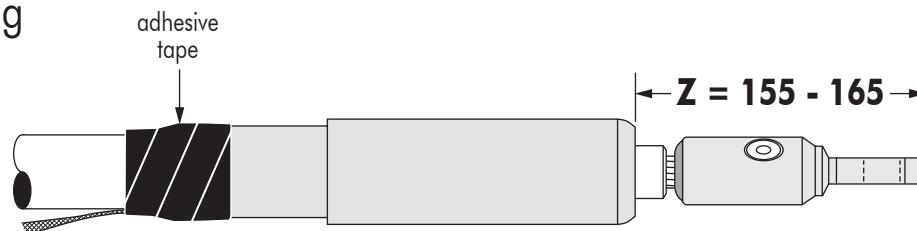

- 6 After tightening, distance «  $Z$  » must be between **155** and **165** mm.  
If necessary, adjust the position of the cable reducer until distance «  $Z$  » is within the tolerance range.  
Using adhesive tape, secure the cable reducer.

## CONNECTOR INSTALLATION ON CABLE

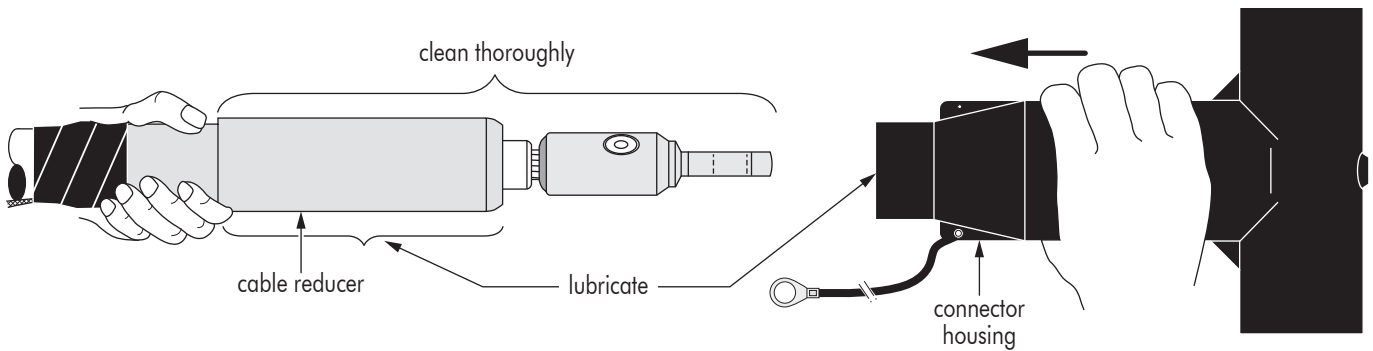

- 1** Clean cable reducer, core insulation and contact.
- 2** Lightly lubricate\* the inside surface of the connector housing and outer surface of the cable reducer.
- 3** Check if the angle of the tee connector housing is correct relative to the palm of the crimp contact.  
Whilst preventing the cable reducer from further movement down the cable, gently slide the housing on the cable until it cannot advance any further.
- 4** The cable reducer must stay in place during installation.

## CONNECTOR INSTALLATION ON BUSHING

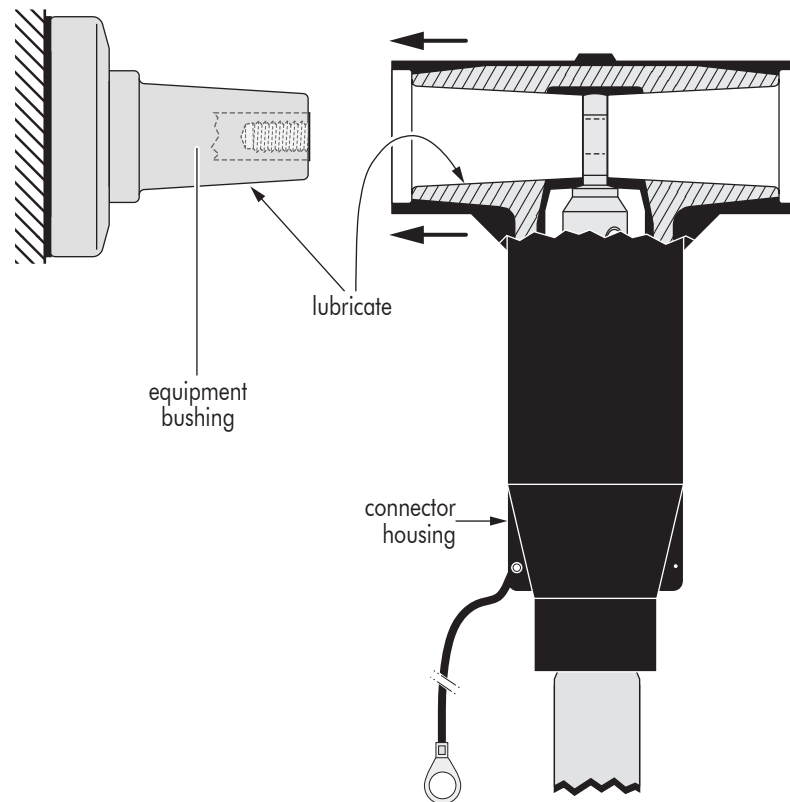

- 1** Clean and lightly lubricate\* both connector and bushing interface.
- 2** Push the connector on to the bushing.

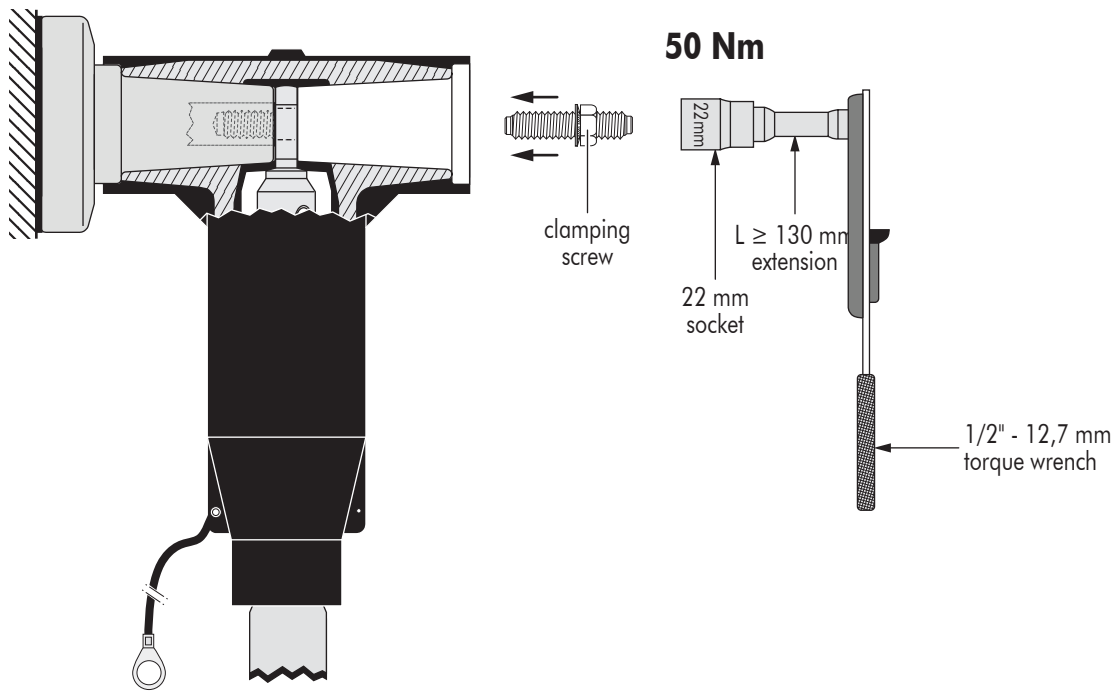

- 3** Insert clamping screw into the threaded hole of the bushing.
- 4** Use torque wrench with a socket wrench 22 and tighten exerting **50 Nm** (5 kgm or 36,9 foot-pounds) of torque **In order to achieve the correct applied torque ensure that there is no lubricant on the threaded parts.**

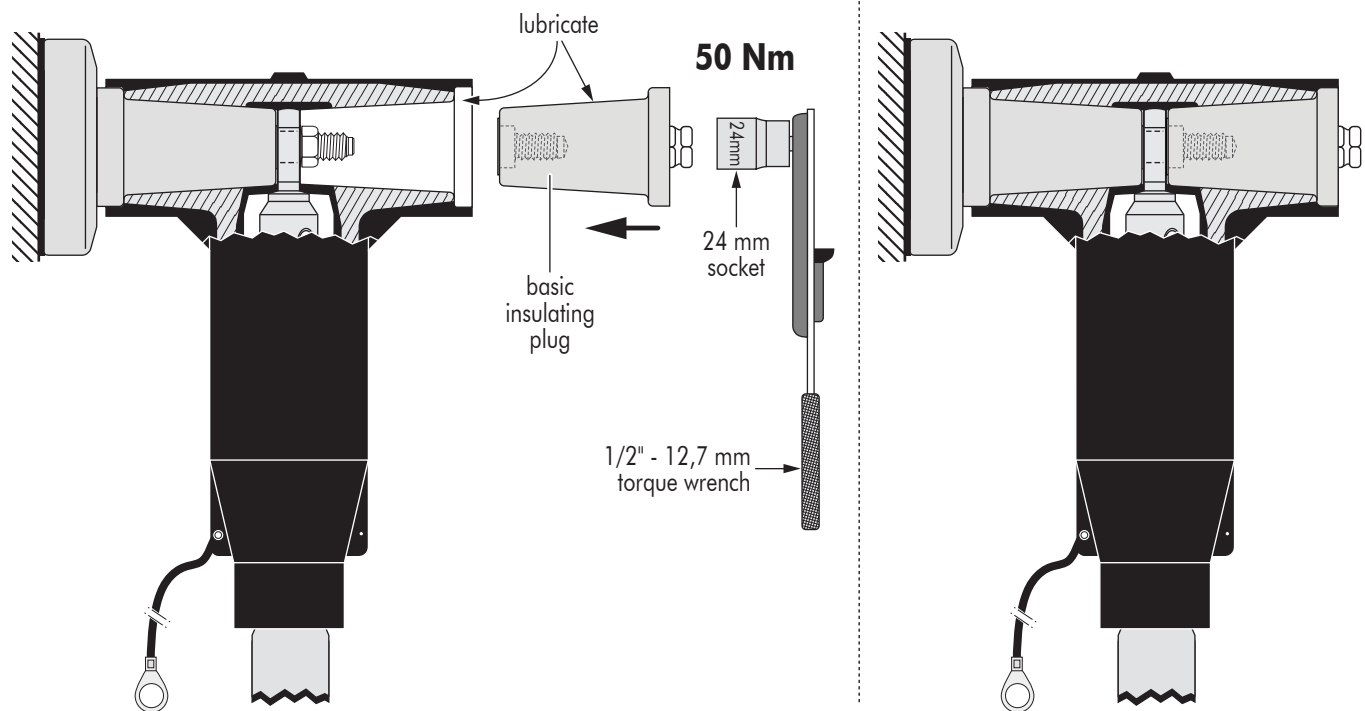

- 5** Clean and lubricate\* the insulating plug for the opposite side of the connector.
- 6** Insert the plug in the connector and tighten assembly : use torque wrench with socket of 24 and tighten exerting **50 Nm** (5 kgm or 36,9 foot-pounds) of torque. **In order to achieve the correct applied torque ensure that there is no lubricant on the threaded parts.**

\* USE ONLY THE SILICONE LUBRICANT SUPPLIED



## INSTALLATION OF THE CAP

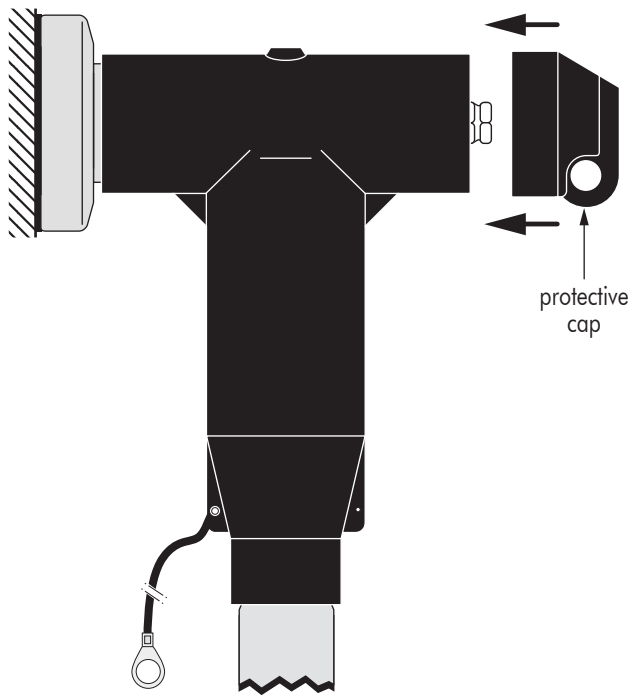

## CONNECTOR EARTHING AND CABLE CLAMPING

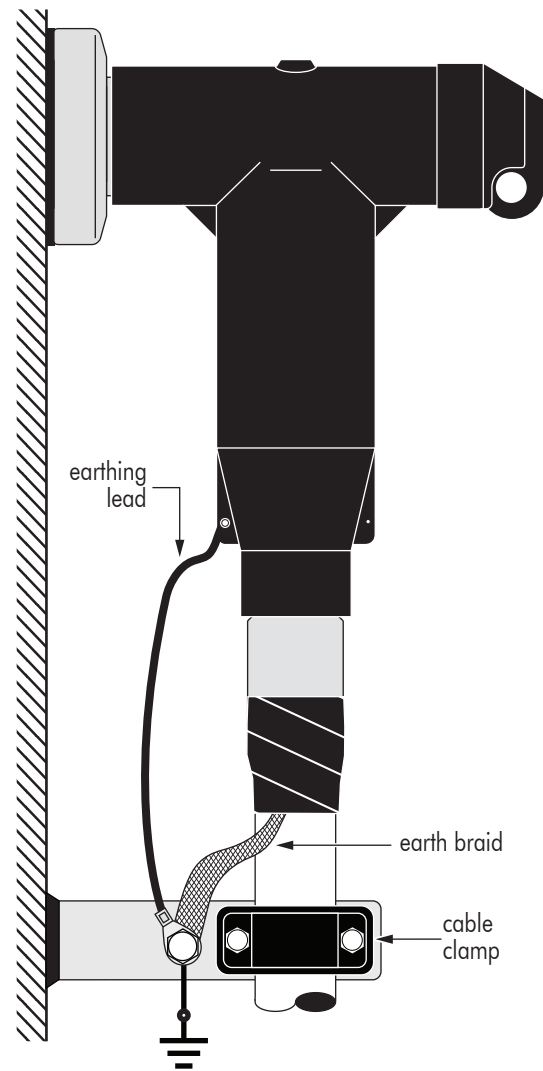

- 8** Clean the inner surface of the protective cap (do not lubricate) and place on the connector. Push down hard until cap "snaps" into place.

Connect the earthing leads and earth braids to the system earth.

### NOTE :

**A connector/bushing mated combination should not be allowed to carry the full weight of the cable. Therefore it is necessary to clamp the cable as close as possible to the connector.**

### IMPORTANT NOTES :

- Never disconnect the connector from energised equipment nor energise a disconnected connector without previously installing on its appropriate corresponding mating part.
- Do not allow hydrocarbon oils or solvents to contaminate the E.P.D.M. rubber. In the event of contamination, wipe the surface clean with a dry cloth.

# Nexans

**Nexans Power Accessories France**  
 BP 17 — 08350 Donchery - France  
 Tél. : +33 (0)3 24 27 78 50 - Fax : +33 (0)3 24 27 78 51  
 nexans.npa.france@nexans.com