

**CAUTION:**

**Read instructions thoroughly and completely prior to beginning installation.**

## Installation instructions

# PEXEM-SR

## Heat-shrinkable indoor and outdoor terminations

**For screened 3-core polymeric insulated cables with and without armour  
7.2 kV - 36 kV**

1. Read the instructions carefully before starting.
2. Use a propane torch for shrinking components.
3. Use a soft yellow flame.
4. Clean and degrease all parts in contact with tapes and adhesives.
5. ENSURE THAT IF ANY CORES ARE CROSSED OR ROLLED THEY ARE DONE SO ON THE AREAS OF THE CORES THAT HAVE SEMI CONDUCTIVE SCREENS. IF THIS IS NOT POSSIBLE DUE TO DIMENSIONS OF EQUIPMENT ENSURE CLEARANCES AS STATED ON PAGE 11 ARE ADHERED TO.

**This product should be installed only by competent personnel trained in good safety practices involving high voltage electrical equipment. These instructions are not intended as a substitute for adequate training or experience in such safety practices. Personnel should be proficient and knowledgeable about preparing and installing medium voltage terminations. These instructions do not attempt to provide for every possible contingency.**

**Failure to follow these instructions could result in damage to the product and serious or fatal injury.**

**IMPORTANT : Cable and associated apparatus must be de-energised, locked out, and tagged prior to product installation.**

Although the installation instructions are describing the correct method for installation of this product, Nexans Power Accessories Ltd has no control over the field conditions that could influence the installation. It is the responsibility of the user to determine the suitability of the installation method for the actual field conditions.

Please refer to Nexans Power Accessories Ltd Standard Terms and Conditions for product liability. In no case can Nexans Power Accessories Ltd be liable for any damages arising from the use or misuse of the products.



## A. Cable with copper tape screen

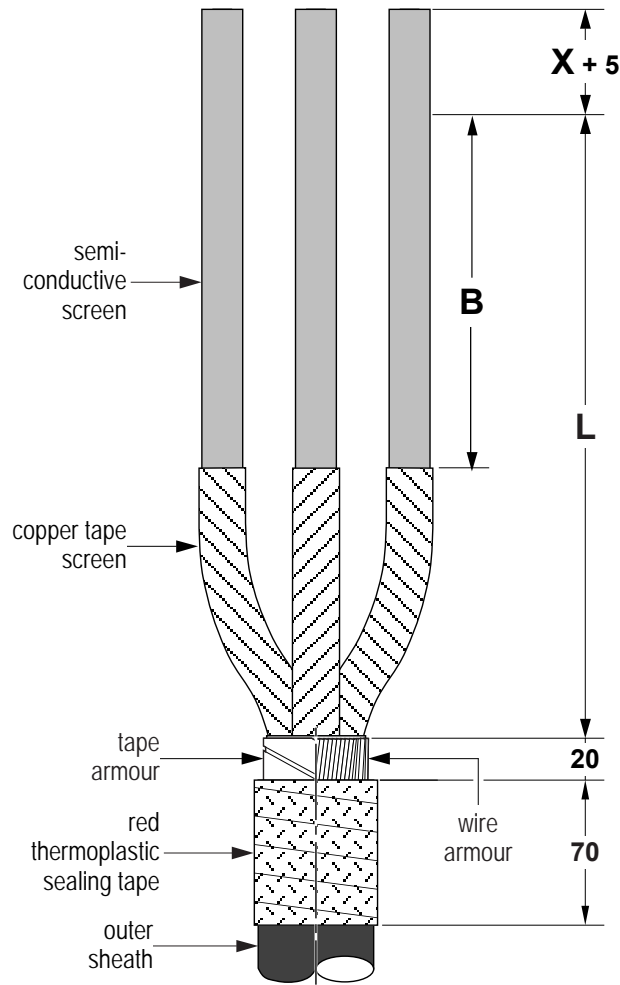

Highest voltage for cable (phase/phase) (kV)	<b>L</b> * indoor straight connection (mm)	<b>L</b> * indoor crossed connection (mm)	<b>L</b> * outdoor (mm)	<b>B</b> (mm)
7.2	250	450	450	210
12	300	450	450	210
17.5	350	500	500	295
24	450	500	500	295
36	600	700	700	440

\*L = min. length required. The actual length will be determined by the overall geometry of the equipment and type of gland used.

Termination of armour will be dictated by the equipment parameters and the type of gland used ( if any ).

1. Remove the outer cable sheath according to the dimension  $L + X$  ( $L$  = see table,  $X$  = depth of the cable lug barrel + 5 mm).
  - 1.1 Remove bedding tape and filler. Clean the cable sheath over a distance of 70 mm and apply one layer of red thermoplastic sealing tape (with 50% overlap).
2. Remove each metal tape screen at dimension  $B$  (See table). Use wire binder or other equivalent method.

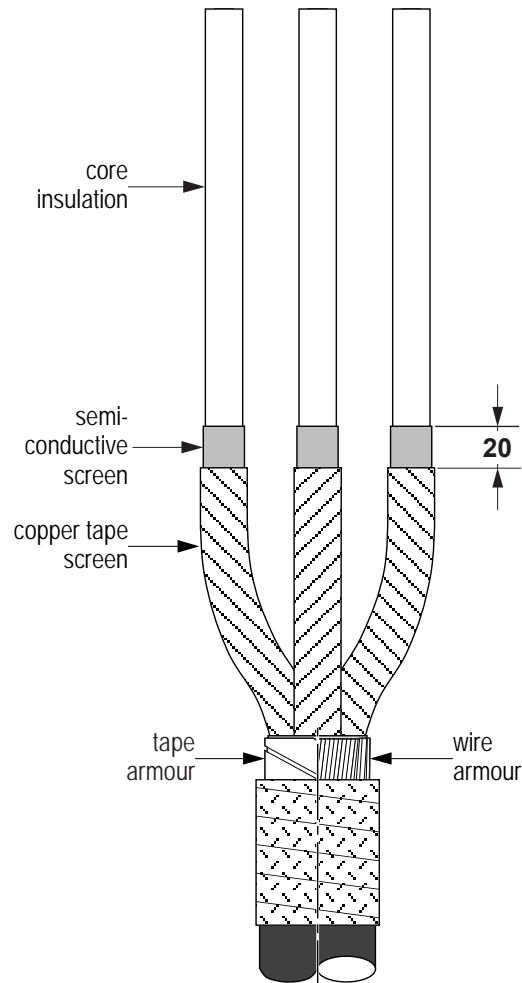

### 3. Removal of the outer semi-conductive screen

#### 3.1 Easy strip semi-conductive screen :

- Remove the semi-conductive screen with a suitable tool to a point 20 mm above the copper tape screen without damaging the core insulation.
- Clean the insulation but avoid contact with the semi-conductive screen.

#### 3.2.Bonded semi-conductive screen :

- Remove the semi-conductive screen with a suitable shaving tool to a point 20 mm above the copper tape screen without damaging the core insulation. The transition from the semi-conductive screen to the insulation has to run out conical.
- Scrape off possible remainders of the conductive screen carefully.
- Clean the insulation but avoid contact with the semi-conductive screen.

#### 3.3.Graphite semi-conductive screen :

- Protect the graphite layer with adhesive vinyl tape (adhesive outside) over a distance of 20 mm above the copper tape screen and wash off the remaining layer with solvent. Remove the vinyl tape.

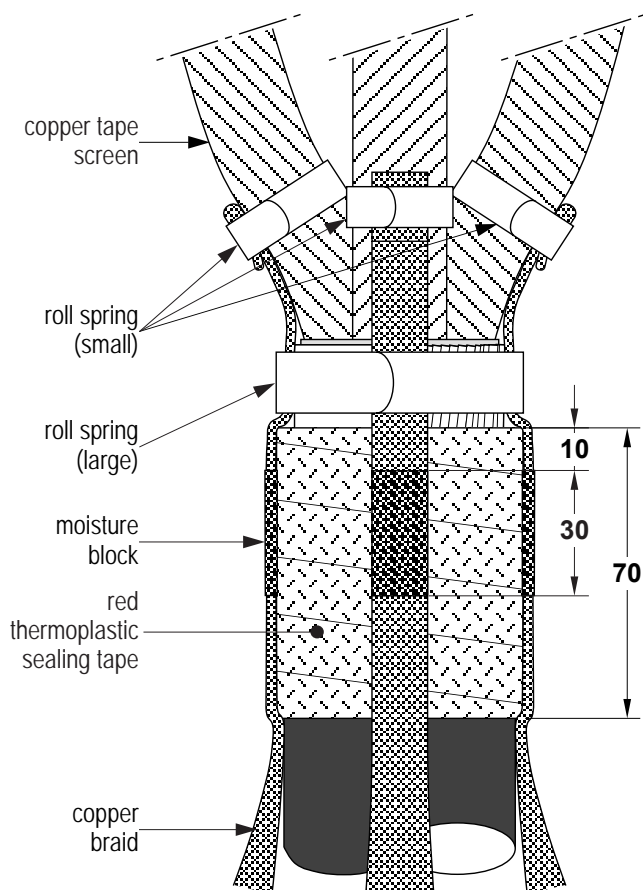

4. Connect earth braid to the copper tape screen of each core, either by soldering or other equivalent method. For cables with armour, also connect the earth braid to the armour by soldering or other equivalent method.

5. Remove conductive tapes and elements, if any, for longitudinal water tightness.

6. Remove the wire binders from the metal tape screens if used.

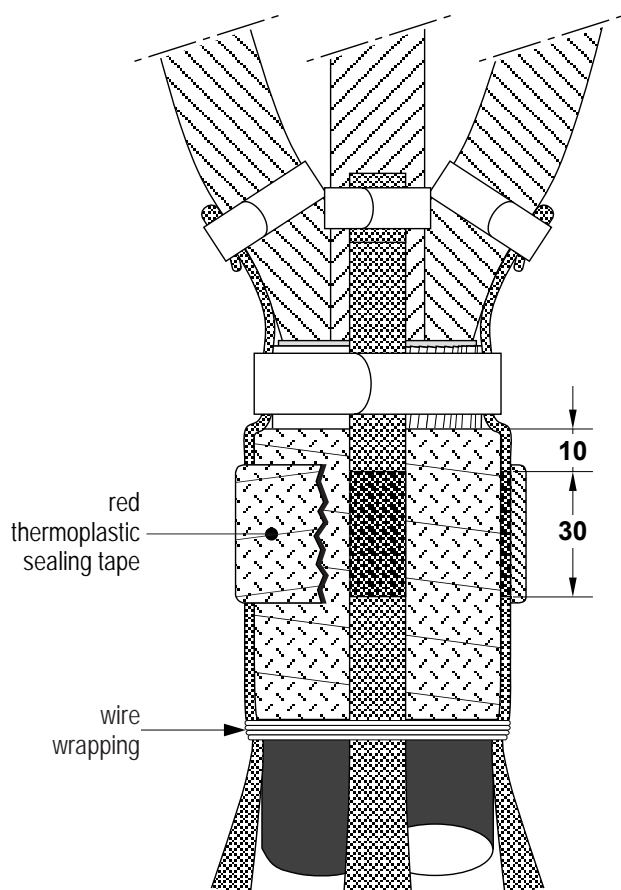

7. Fix the braid with a wire wrapping at 70 mm below the outer sheath. Cut the earth braids at the required length and crimp the cable lugs.

8. Apply a layer of red thermoplastic sealing tape (with 50% overlap) at 10 mm below the cable sheath edge, over the braids.

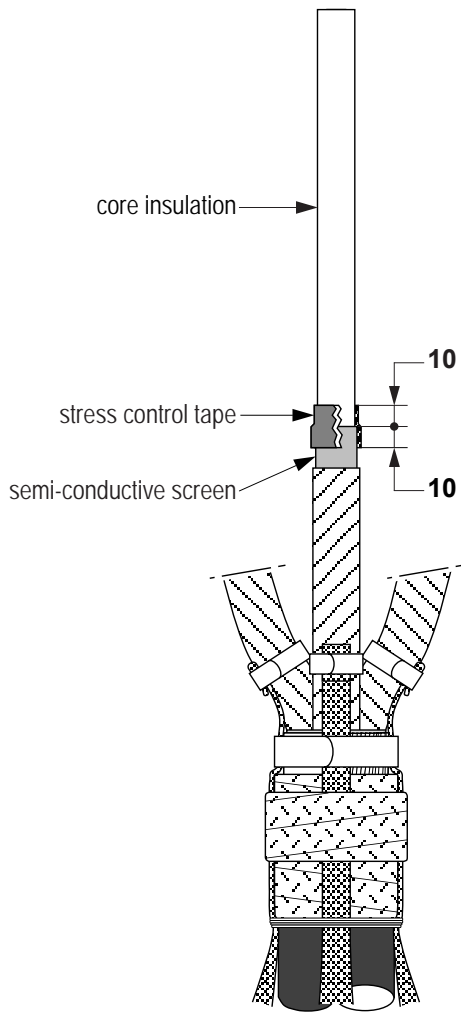

9. Wrap, while stretching, two layers of stress control tape on the cutback edge of the semi-conductive screen (not on graphite semi-conductive layer) 10 mm above and 10 mm below the transition point.

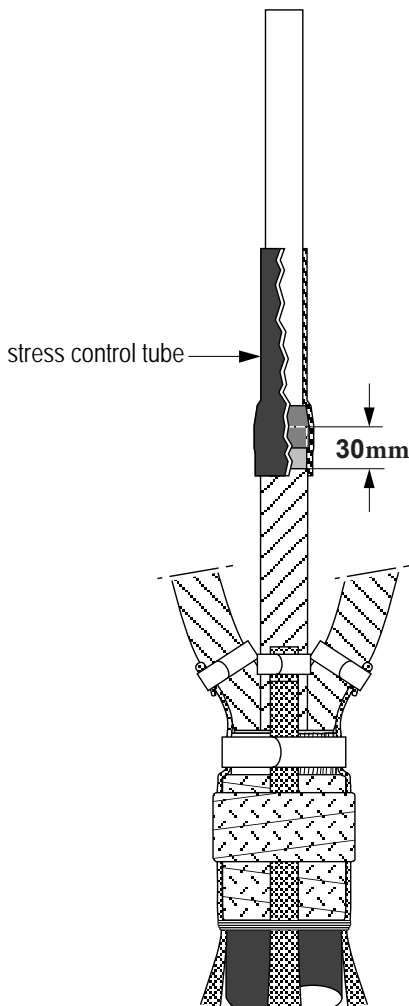

10. Place the stress control tubes (black) over the cores and position them according to drawing. Shrink down the tubings starting at the bottom and working upwards.

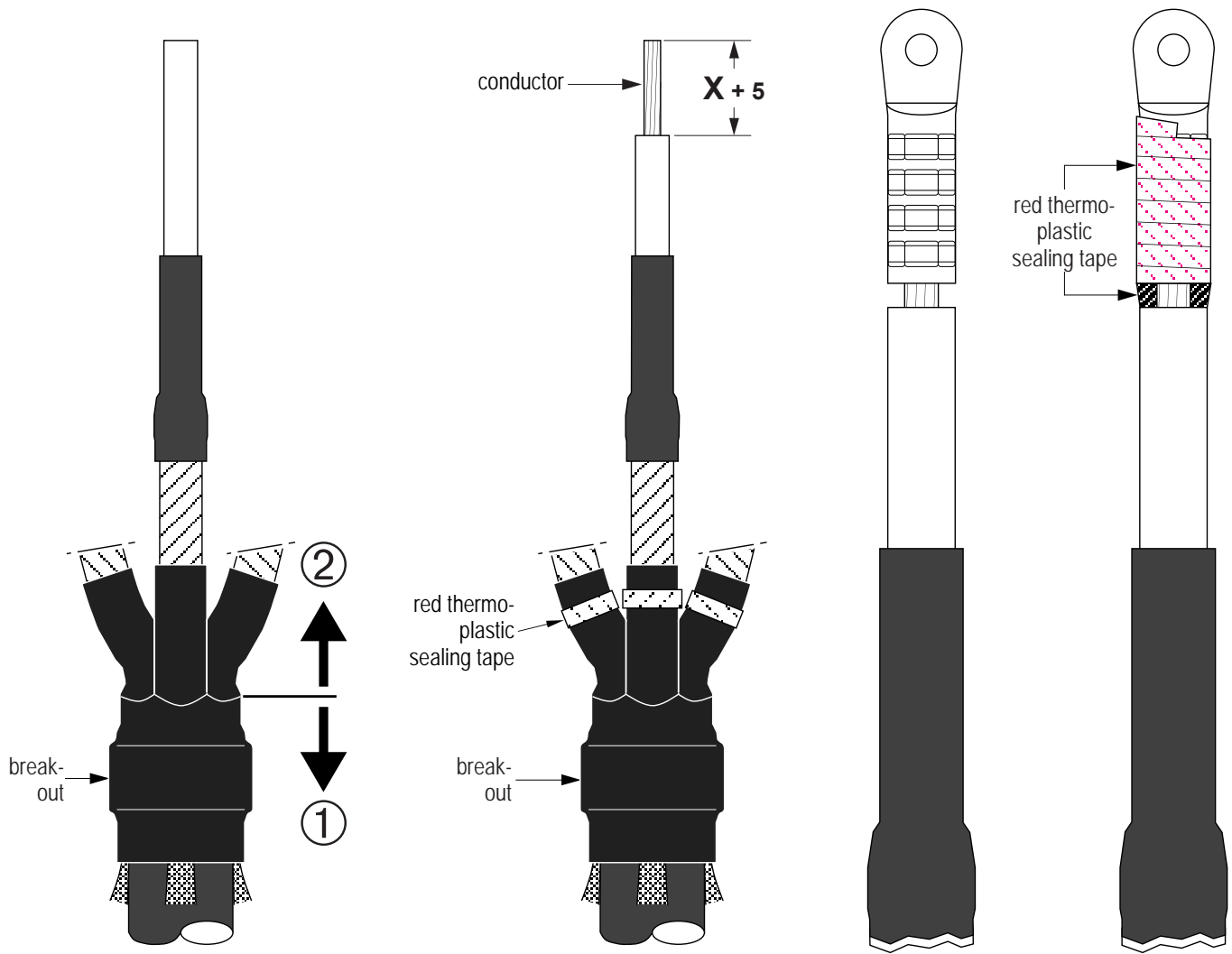

11. Pass the adhesive-coated breakout over the cores and pull it as far down into the crutch as possible. Shrink the breakout into place starting at the centre. Work first towards the lower end, then shrink the turrets onto the cores.

12. Apply one layer of red thermoplastic sealing tape on each turret.

13. Cut back the core insulation according to the dimension X ( $X = \text{cable lug barrel depth} + 5 \text{ mm}$ ).

14. Install and crimp the cable lugs and remove any sharp edges.  
Clean the lug barrels and the insulation.

15. Apply two layers of red thermoplastic sealing tape (50% overlap) on the cable lug barrels and fill the gap between core insulation and the cable lug barrel.

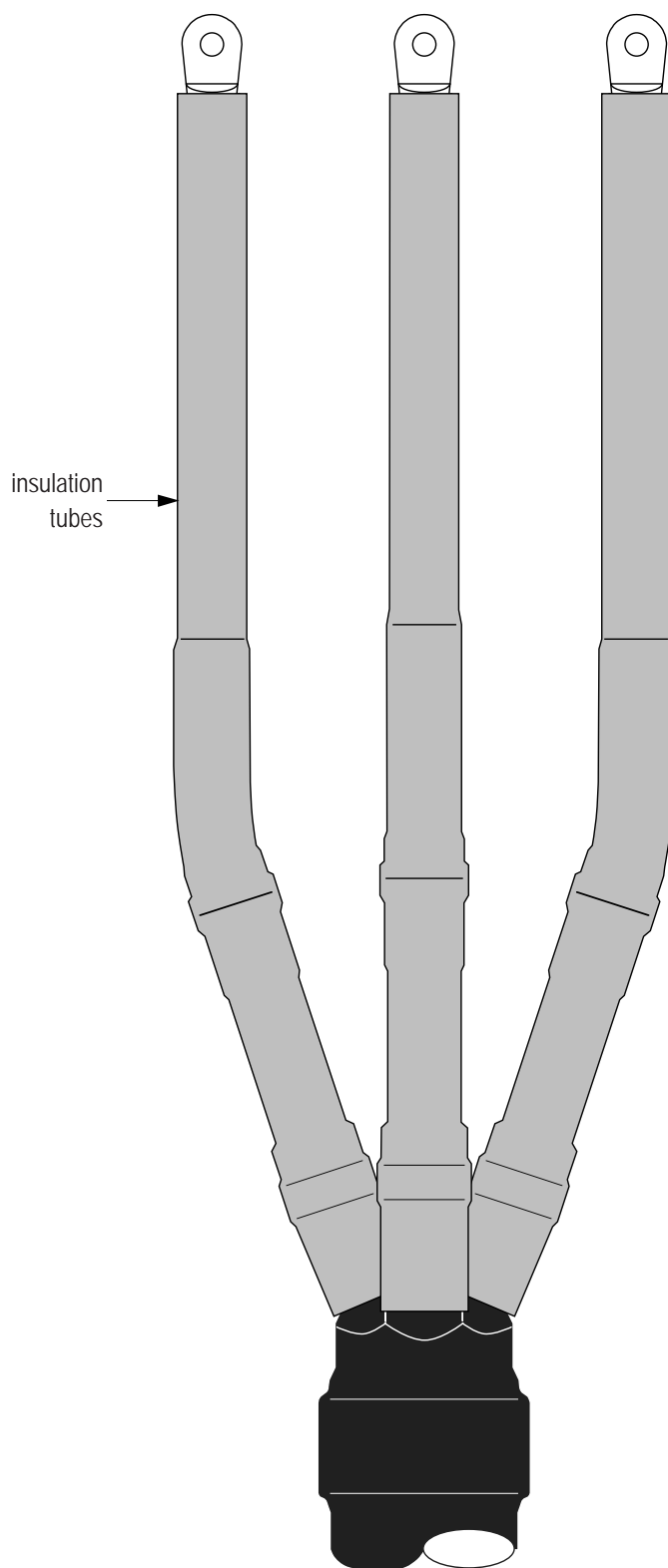

16. Place the insulation tubes over the cores. Push the tubings over the breakout turrets as far as possible and shrink down starting at the crutch.  
Cut any excess tube on the cable lug barrel.

17. For indoor terminations above 12 kV and outdoor types, install the sheds and shrink them in place according the dimensions given on the drawing on page 10. Make sure that the core to core clearance between sheds is maintained with the cores in their final position.

**For cable with copper tape screen : continue the installation on page 10.**

---

## B. Cable with wire screen

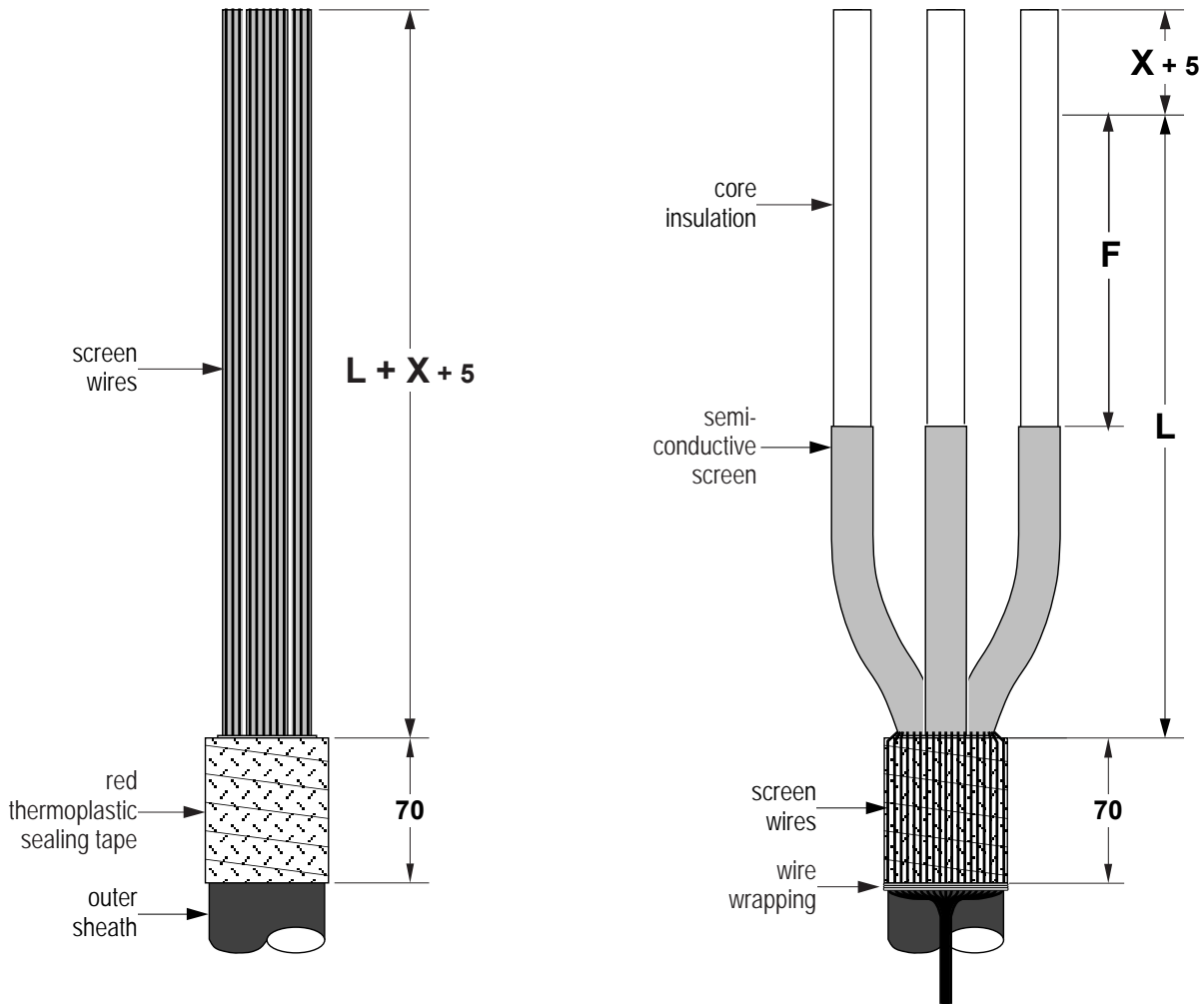

Highest voltage for cable (phase/phase) (kV)	<b>L</b> * indoor straight connection (mm)	<b>L</b> * indoor crossed connection (mm)	<b>L</b> * outdoor (mm)	<b>F</b> (mm)
7.2	250	450	450	190
12	300	450	450	190
17.5	350	500	500	275
24	450	500	500	275
36	600	700	700	420

\*L = min. length required. The actual length will be determined by the overall geometry of the equipment and type of gland used.

1. Remove the outer cable sheath according to the dimension  $L + X$  ( $L$  = see table,  $X$  = depth of cable lug barrel + 5 mm). Remove bedding tape and copper tape over wire screen. Clean the outer cable sheath over a distance of 70 mm and apply a layer of red thermoplastic sealing tape (with 50% overlap).
2. Bend back the copper wires over the sheath in a parallel way so that each wire rests upon the red thermoplastic sealing tape. Fix the wires with a wire wrapping (2 to 3 windings) at about 70 mm below the cutback edge of the sheath. Twist the copper wires together, cut them at the right length, and install the cable lug. For cables with armour, also connect the wire screen to the armour by soldering or an other equivalent method.
3. Remove conductive tapes and elements, if any, for longitudinal water tightness.



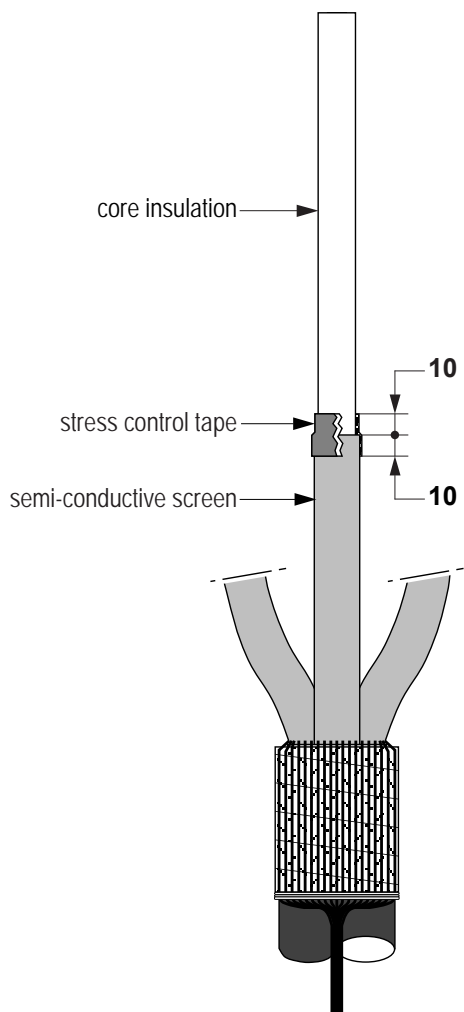

4. Wrap, while stretching, one layer of stress control tape on the cutback edge of the semi-conductive screen (not on graphite semi-conductive layer) 10 mm above and 10 mm below the transition point.

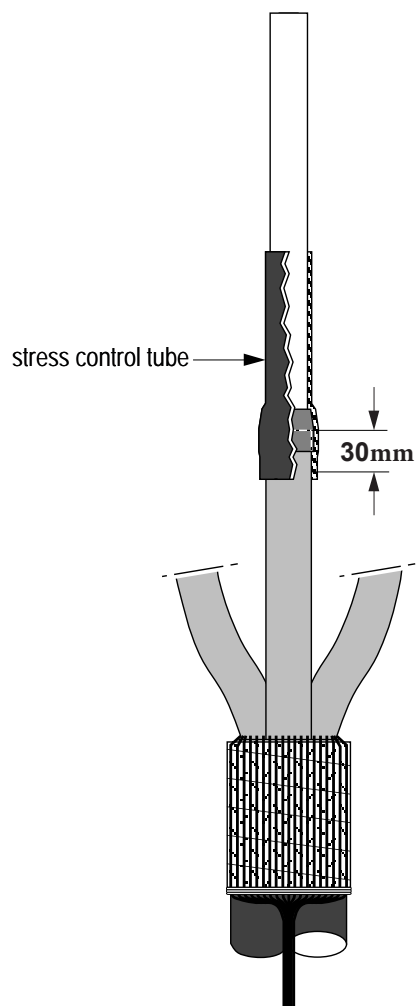

5. Place the stress control tubes (black) over the cores and position them according to drawing.  
Shrink down the tubings starting at the bottom and working upwards.

**Continue the installation starting at step 11 on page 6.**

**INDOOR**

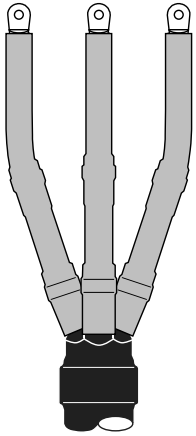

**7.2 & 12 kV**

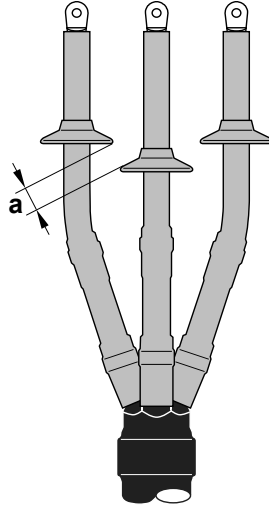

**17.5/24 kV**

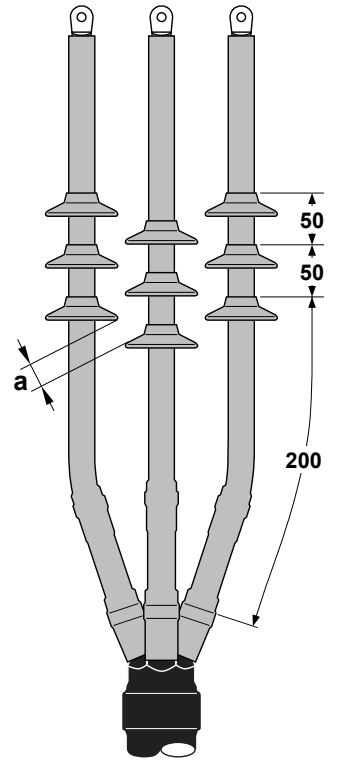

**36 kV**

Minimum clearance between sheds :					
Voltage (kV)	7.2	12	17.5	24	36
<b>a</b> (mm)	10	10	15	20	25

**OUTDOOR**

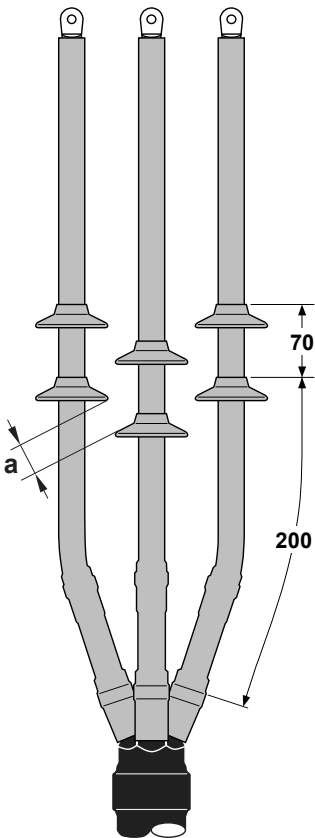

**7.2 kV**

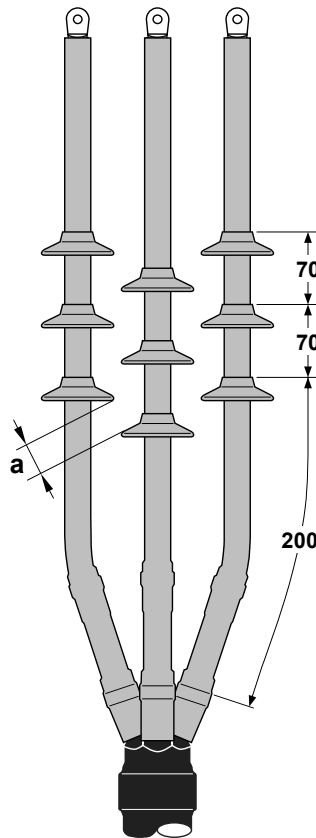

**12 kV**

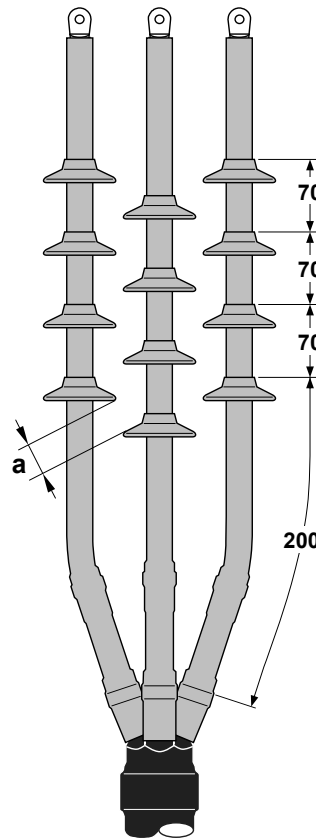

**17.5/24 kV**

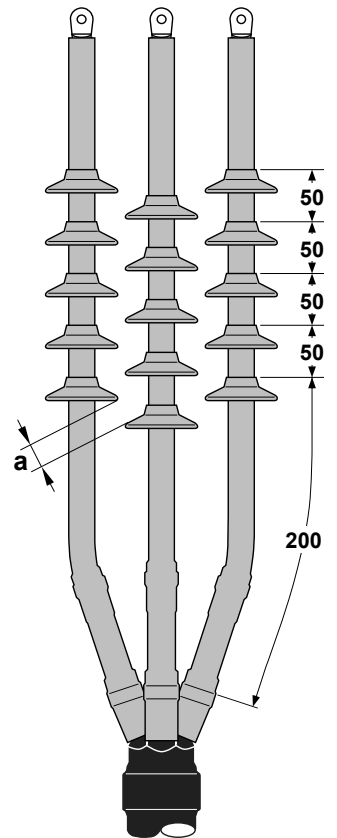

**36 kV**

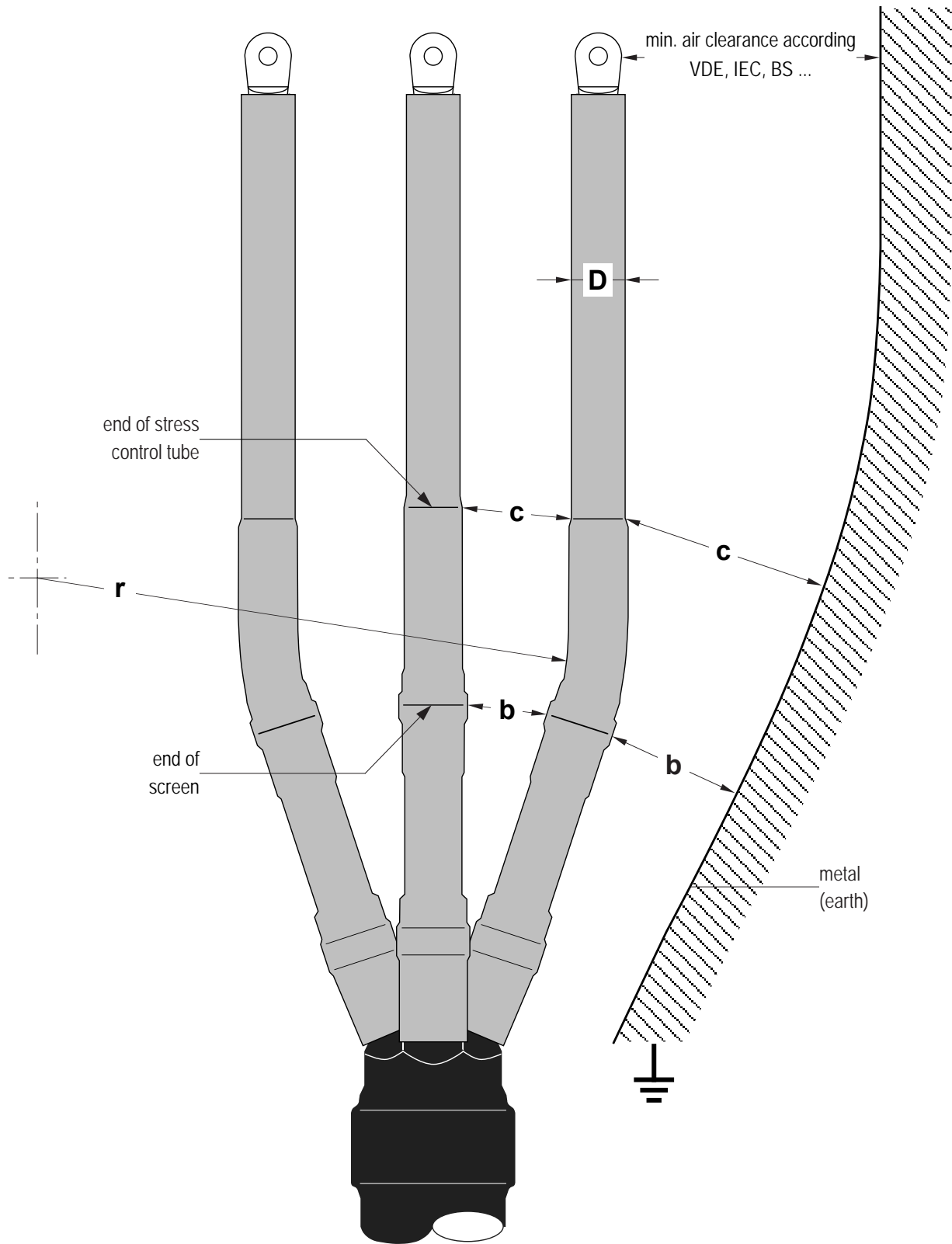

Minimum bending radius $r = 10 \times D$ ; before bending, heat cores up to approx. 70°C.					
Minimum clearance phase/phase and phase/earth :					
<b>Voltage (kV)</b>	<b>7.2</b>	<b>12</b>	<b>17.5</b>	<b>24</b>	<b>36</b>
<b>b (mm)</b>	10	15	20	25	35
<b>c (mm)</b>	15	20	30	40	50