



Cembre



ISO 9001
Certified Quality
Management System



ISO 14001
Certified Environmental
Management System



OHSAS 18001
Certified Occupational
Health & Safety
Management System

ENGLISH

HYDRAULIC PRESSHEAD







RHU600



**OPERATION AND MAINTENANCE
MANUAL**

WARNING

 DANGER	 CAUTION	 WARNING TG.0934
 <p style="margin: 0;">ELECTROCUTION HAZARD</p> <p style="margin: 0;">The user should be properly trained in the correct procedures required for work on or around electrical lines.</p>	<p>Operating and safety procedures may vary in accordance with the guidelines of each utility. For your own safety, ensure that you fully comply with all "safe operation" practices required by your respective power utility.</p>	<p>BEFORE USING THIS TOOL, READ THE SAFETY WARNINGS and recommended practices described in the manual. Failure by the operator to read and fully understand the warnings will leave this person unqualified to use and operate the tool. Failure to observe all warnings and instructions may result in property damage, severe personal or third party injury or death.</p>

CAUTION
TG.0947

Before operating make sure the latch is secure. Latch improperly secured may cause tool damage and personal injury.



1	<i>Before using the tool, carefully read the instructions in this manual.</i>
2	<i>When operating the tool, keep hands away from the danger zone.</i>
3	<i>Operate only with dies and product inserted.</i>
4	
	<p><i>Use this tool for its intended purpose only.</i></p> <p><i>Inspect tool before use, replace any worn or damaged parts.</i></p> <p><i>Inspect pump hydraulic hoses and couplings before each use.</i></p> <p><i>Clear work area.</i></p> <p><i>Always maintain a firm grip on the tool during operation.</i></p>

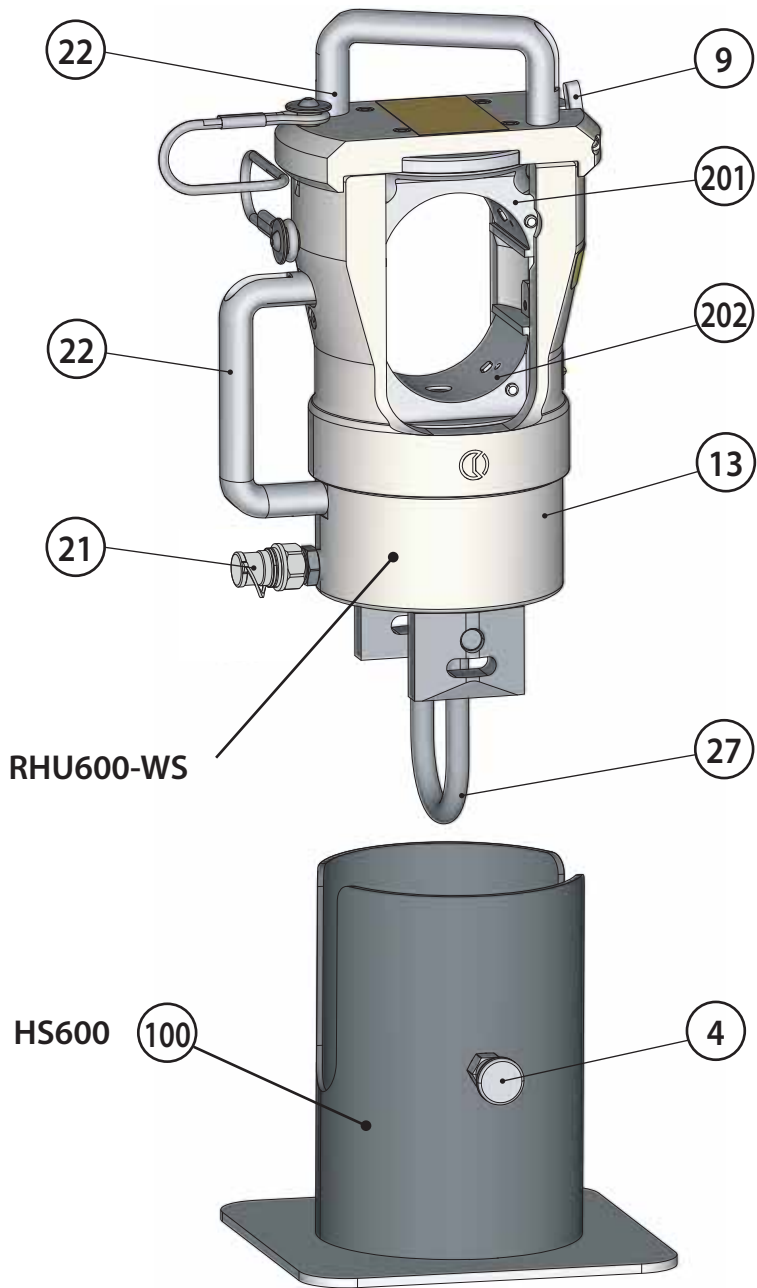

RHU600-WS

HS600

FIG. 1

HYDRAULIC PRESSHEAD RHU600

1. GENERAL CHARACTERISTICS

- **Application range:** suitable for installing compression connectors on conductors up to1022 mm² (2156 MCM) Al and Cu
- **Crimping force:**.....600 kN (67 sh ton)
- **Max. operating pressure:**.....700 bar (10,000 psi)
- **Oil necessary (displacement):**.....320 cm³ (18.9 cu. in)
- **Ram stroke:**.....34 mm (1.33 in.)
- **Weight RHU600 (head with support):**.....22,4 kg (49.3 lbs)
- **Weight RHU600-WS (head without support):**.....19 kg (41.8 lbs)
- **Weight SH600 (support):**.....3,4 kg (7.5 lbs)
- **Dimensions mm (inch):**

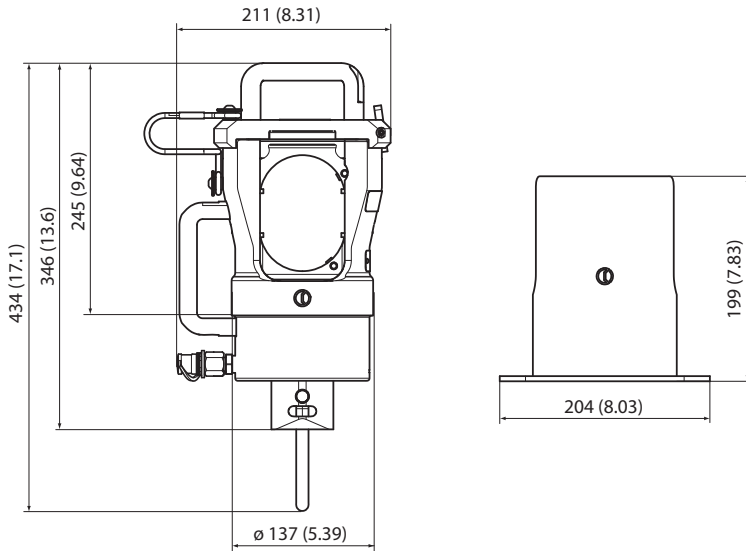

- **Description:** (Ref. to Fig. 1)
 - 4 - HEAD RELEASE KNOB
 - 9 - DIE HOLDER LATCH
 - 13 - U-FORK
 - 21 - MALE QUICK COUPLER
 - 22 - HANDLE
 - 27 - HANGER (for suspended use)
 - 100 - HEAD SUPPORT (for use on a stable, level surface)
 - 201 - TOP DIE HOLDER
 - 202 - RAM

2. INSTRUCTIONS FOR USE

For use on a level and stable surface, e.g the ground, the head should be mounted and locked with the knob (4) on the **HS600** support base provided.

Alternatively, the head may be suspended for use, via the integral hanger (27), **ensuring the suspension method is secure and safe.**

2.1) Setting

- Connect the presshead to the pump hose; the head is equipped with a "self-lock" quick male coupler and can be connected to a **Cembre** hydraulic pump developing **700 bar (10,000 psi)** pressure.

2.2) Die insertion (Ref. to Fig. 3)

Make sure that the top die holder and the latch are correctly located.



BEFORE OPERATING MAKE SURE THE LATCH IS SECURE. LATCH IMPROPERLY SECURED CAN CAUSE TOOL DAMAGE AND PERSONAL INJURY.

- Select the appropriate die set for the connector.
- Insert the die (90) in the upper seat of the top die holder (201) until it is locked by die/head pin (6). To ease the die insertion, keep die/head release pin (4) depressed.
- Insert the die (91) into the seat on the ram (202) until it is locked by die/ram retaining pin (6); To ease this operation, keep die/ram release pin (4) depressed.



NEVER PRESSURIZE THE HEAD WITHOUT THE DIE IN PLACE AS SERIOUS DAMAGE AND/OR PERSONAL INJURY MAY RESULT.

2.3) Die positioning

- Insert the conductor into the connector (see § 2.6).
- Locate the connector between the dies at the desired crimp position.
- Operate the pump until the dies touch the connector.
Make sure that dies are exactly positioned on desired crimp point, otherwise re-open dies following instructions as per § 2.5 and position the connector again.

2.4) Crimping

- Operate the pump to advance the ram until the die faces touch.
It is recommended to continue pumping until the maximum pressure valve is activated and a "click" is heard.
- Re-open dies (see § 2.5) and repeat steps above as necessary.

2.5) Die opening

- Fully discharge the oil pressure from the pump to retract the ram (202) and release the crimped connector.



CHECK THAT THE RAM IS COMPLETELY RETRACTED BEFORE DISCONNECTING THE HOSE FROM THE HEAD.

2.6) Head opening (Ref. to Fig. 4)

When required, the upper part of the head can be disconnected to permit an easy introduction of the connector or, if necessary, the connector removal after crimping; operate as follows:

- Hold the handle (22), press the latch (9) and turn the top of the head through 90 degrees.
- Introduce the connector then replace the top of the head.

Before proceeding with the crimping operations, please **verify that the head is correctly reassembled and latch (9) is correctly located.**

3. MAINTENANCE

The head is robust and requires very little daily maintenance.

Inspect for wear and damage. Worn or damaged parts may malfunction during head operation.

The parts must be replaced if signs of wear or damage are evident.

Compliance with the following points should help to maintain the optimum performance of the tool.

3.1) Accurate cleaning

Dust, sand and dirt are a danger for any hydraulic device.

Avoid putting the head on muddy or dusty ground as dirt particles may score the ram and create oil leaks.

Every day, after use, the head must be wiped with a clean cloth, taking care to remove any residue, especially around moving parts.

3.2) Replacement of the automatic coupler

To replace the automatic coupler proceed as follows:

- Remove the old coupler.
- Carefully clean the thread to remove the old sealant.
- Apply Teflon tape to the thread.
- Fit the new automatic coupler and tighten to **30 Nm (22 lbf ft).**

3.3) Storage (Ref. to Fig. 2)

When not in use, the head should be stored and transported in the specific steel case to prevent damage.

Steel case: **VAL600**, size 480x235x260 mm (18.9x9.2x10.2 in.) weight 8,6 kg (18.9 lbs) suitable for storing the head complete with support.



FIG. 2
VAL600 METAL CASE

4. RETURN TO **Cembre** FOR OVERHAUL

In the case of a breakdown, contact our **Area Agent** who will advise you on the problem and give you the necessary instructions on how to dispatch the tool to our **nearest service Centre**; if possible, include a copy of the Test Certificate supplied by **Cembre** with the tool or, if no other references are available, indicate the approximate purchase date and the tool serial number.

SPARE PARTS LIST

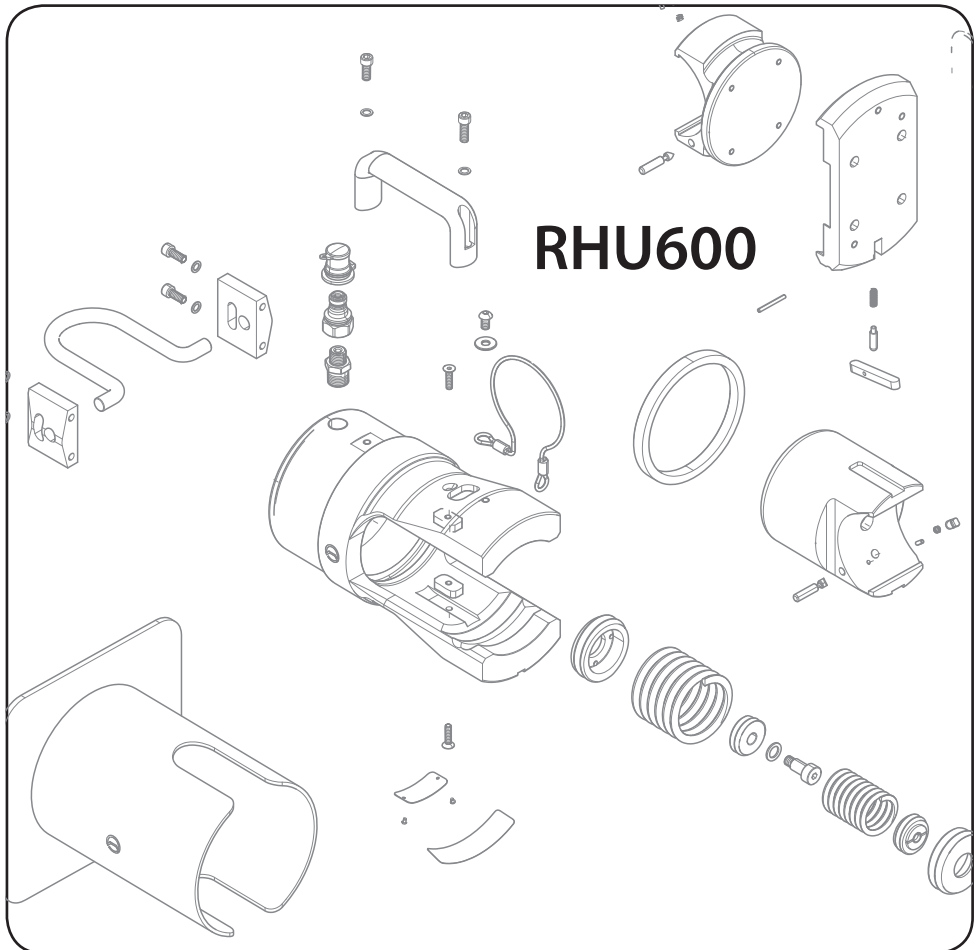
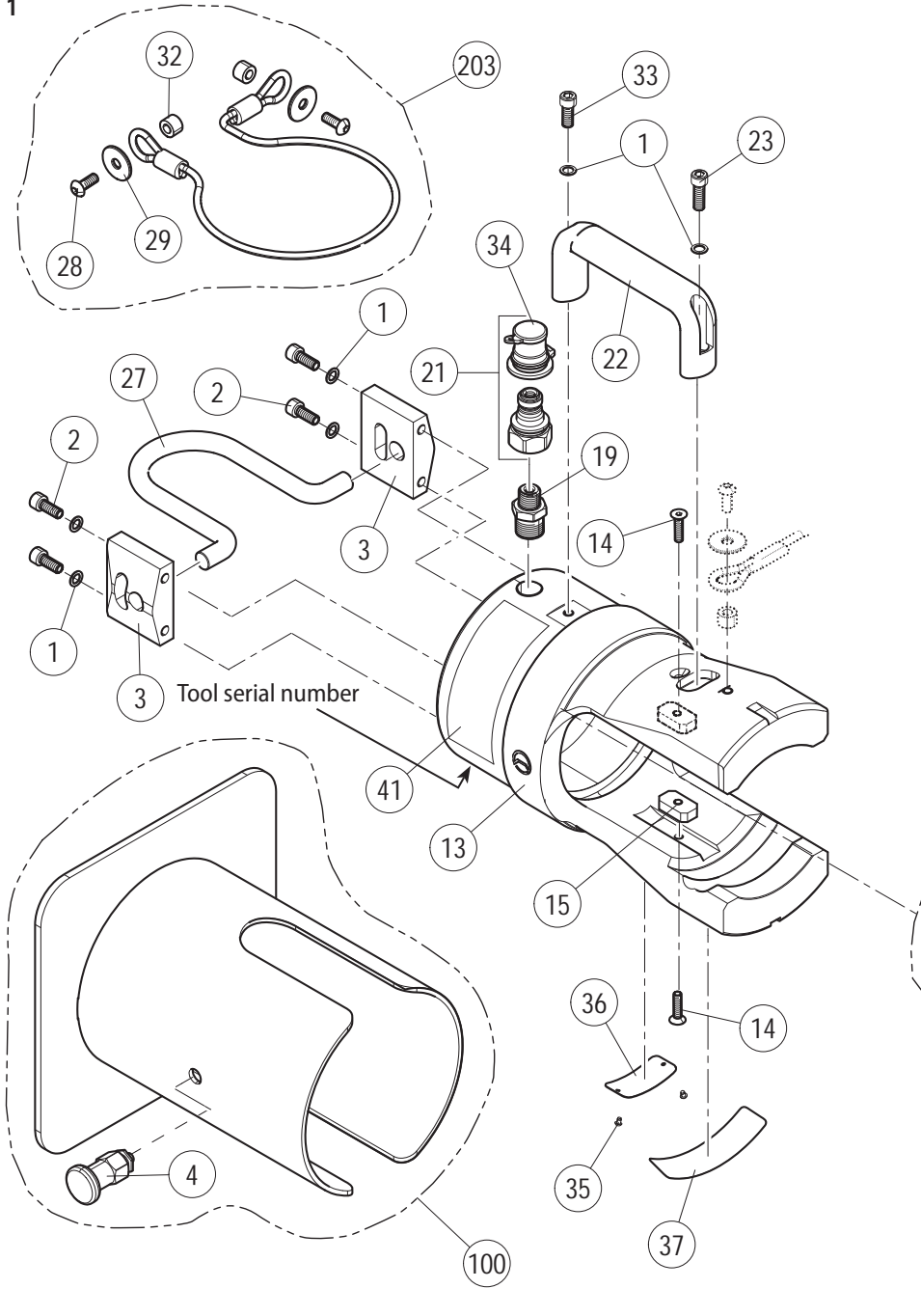

TABLE 1



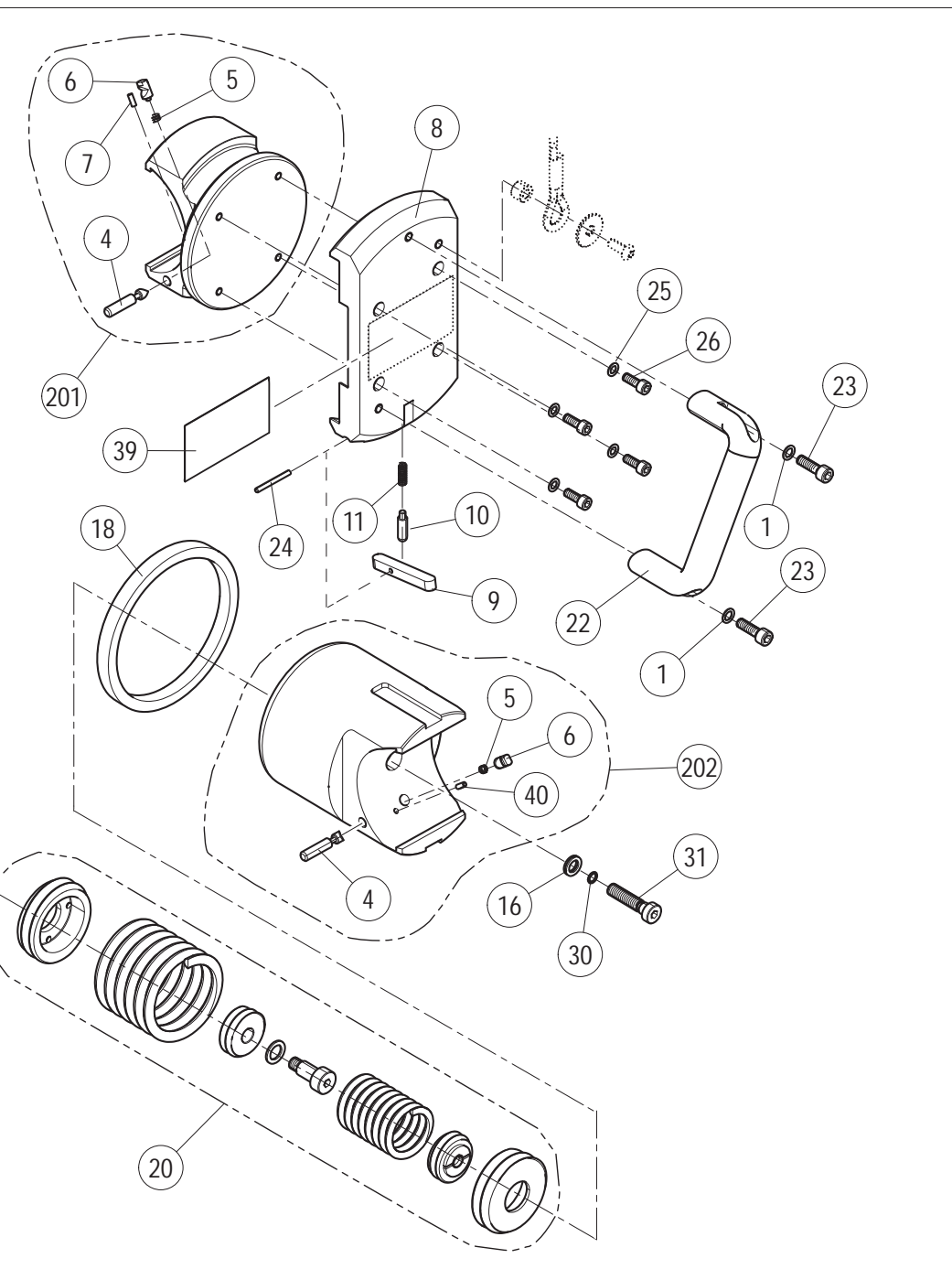

TABLE 1

Code N°	Item	DESCRIPTION	Qty
6640112	1	D.6 SCHNORR WASHER	8
6900325	2	M6x16 SCREW	4
6780166	3	HANGER BLOCK	2
6780119	8	DIE HOLDER SUPPORT	1
6640185	9	LATCH	1
6600019	10	PIN	1
6520529	11	SPRING	1
6280167	13	FORK	1
6900281	14	SCREW M5x20	2
6100044	15	KEY	2
6640194	16	NORD-LOCK WASHER	1
6362090	18	SEAL	1 K
6525072	19	NIPPLE	1
6520441	20	COMPLETE SPRING	1
6060120	21	Q14-MS QUICK COUPLER	1
6490074	22	HANDLE	2
6900299	23	M6x20 SCREW	3
6760166	24	D.3X30 PIN	1
6640096	25	D.5 SCHNORR WASHER	4
6900253	26	M5x14 SCREW	4
6580642	27	HANGER	1
6362089	30	SEAL	1 K
6900559	31	SCREW	1
6900325	33	M6x16 SCREW	1
6800186	34	PROTECTION CAP	
6650118	35	ø2,5x3,5 RIVET	2
6232567	36	TG.0778 TOOL NAMEPLATE	1
6232006	37	TG.0356 WARNING LABEL	1
6232692	39	TG.0935 WARNING LABEL	1
6232691	41	TG.0945 WARNING LABEL	1
2640260	100	COMPLETE HEAD SUPPORT (HS600)	1
6620350	100 4	RELEASE KNOB	1
6506657	201	COMPLETE DIE HOLDER	1
6620443	201 4	PIN	1
6522006	201 5	SPRING	1
6620339	201 6	PIN	1
6760040	201 7	D.3x8 SPLIT PIN	1
6620541	202	COMPLETE RAM	1
6620443	202 4	PIN	1
6522006	202 5	SPRING	1
6620339	202 6	PIN	1
6760415	202 40	POSITIONING PIN	1
6170082	203	COMPLETE CABLE	1
6900291	203 28	M6x16 SCREW	2
6640114	203 29	Ø6,5xØ24x2 WASHER	2
6080098	203 32	BUSH	2

The guarantee is void if parts used are not Cembre original spares.

The items marked "K" are those **Cembre** recommend replacing if the tool is disassembled. When ordering spare parts always specify the following:

- code number of item - name of item - type of tool - serial number of tool

FIG. 3

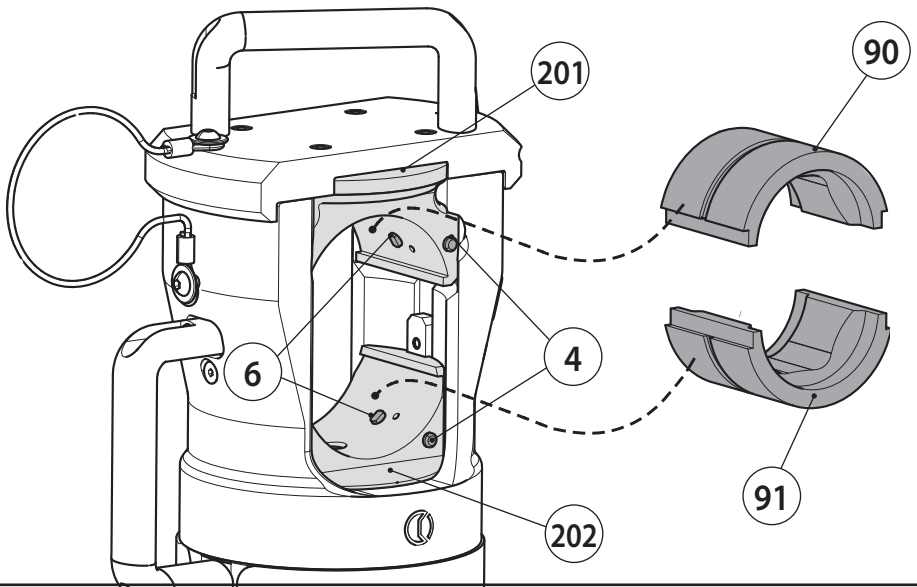
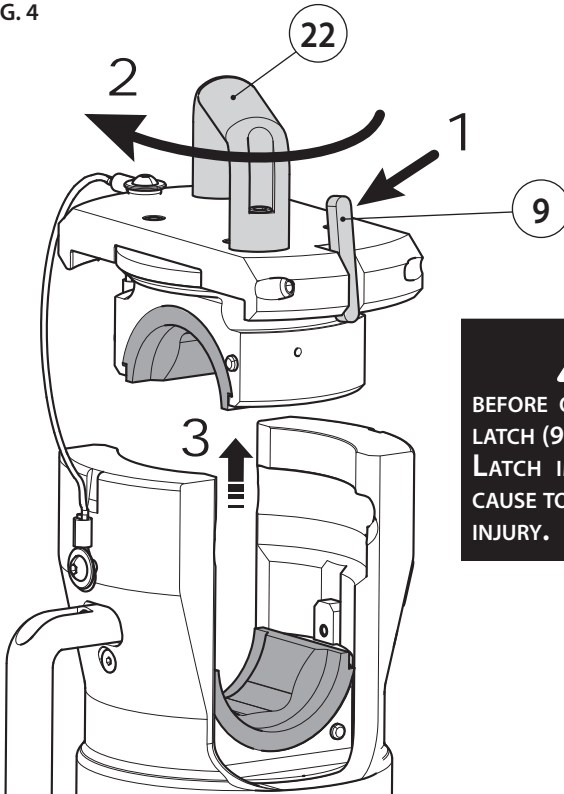

FIG. 4



⚠ CAUTION
BEFORE OPERATING MAKE SURE THE LATCH (9) IS SECURE.
LATCH IMPROPERLY SECURED CAN CAUSE TOOL DAMAGE AND PERSONAL INJURY.



Cembre S.p.A.
Via Serenissima, 9
25135 Brescia (Italia)
Telefono: 030 36921
Telefax: 030 3365766
E-mail: sales@cembre.com
www.cembre.com

Cembre Ltd.
Dunton Park
Kingsbury Road, Curdworth - Sutton Coldfield
West Midlands B76 9EB (UK)
Tel.: 01675 470440 - Fax: 01675 470220
E-mail: sales@cembre.co.uk
www.cembre.co.uk

Cembre S.a.r.l.
22 Avenue Ferdinand de Lesseps
91420 Morangis (France)
Tél.: 01 60 49 11 90 - Fax: 01 60 49 29 10
CS 92014 - 91423 Morangis Cédex
E-mail: info@cembre.fr
www.cembre.fr

Cembre España S.L.U.
Calle Verano 6 y 8
28850 Torrejón de Ardoz - Madrid (España)
Telefono: 91 4852580
Telefax: 91 4852581
E-mail: comercial@cembre.es
www.cembre.es

Cembre GmbH
Heidemannstraße 166
80939 München (Deutschland)
Telefon: 089 3580676
Telefax: 089 35806777
E-mail: sales@cembre.de
www.cembre.de

Cembre Inc.
Raritan Center Business Park
181 Fieldcrest Avenue
Edison, New Jersey 08837 (USA)
Tel.: (732) 225-7415 - Fax: (732) 225-7414
E-mail: sales.US@cembreinc.com
www.cembreinc.com