



**100%
MADE IN
GERMANY**



Cable Clamps for single and multi-core cables

Maximum short circuit resistance for all voltage ranges
and the most extreme conditions



Management
System
ISO 9001:2015

www.tuv.com
ID 0910083059

www.id-technik.com

id-Technik®
The original since 1977

id-Technik is the original developer

For more than forty years, id-Technik has been developing cable fastening systems designed to provide reliable support, restrain cable movement and withstand short-circuit forces. In the 1970s, many power cable systems started to use XLPE insulated cables instead of lead-sheathed paper-insulated cables. Three-conductor designs had been common with the traditional cables, while the newer cable systems tended to use single conductor cables. It soon became evident that cable-clamping schemes that had been adequate for the older types of cable were now being exposed to stronger electromechanical forces during short circuit events. Additional mechanical restraint was required to prevent movement of single conductor cable systems. Early support system modifications typically reduced the spacing distance between clamping points to provide more reliable restraint; however, this was costly to implement. With an expected lifetime of forty, or more, years, the development of a reliable, cost-effective means of supporting and restraining those cables became increasingly important. This challenge prompted Klaus Dörrstein, the founder

of id-Technik GmbH, to focus on developing cable clamping system designs that would meet the requirements of modern cable systems. This led to the development of cable clamping systems suitable for a wide range of cable types, system designs, installation conditions and short-circuit forces. From the initial observation of the potential for improvement in cable support and restraint systems, the work has expanded into the development of an internationally recognised system for cable support and short-circuit restraint.

id-Technik was the first manufacturer to develop short-circuit-proof cable clamps made of high-quality polyamide and these are now used around the world. With IEC 61914 type tests and ISO 9001 certifications, cable system designers can rely on the proven quality of id-Technik now and into the future.

We guarantee the highest level of safety and proven performance for our products and systems.

Dr. Janine Dörrstein

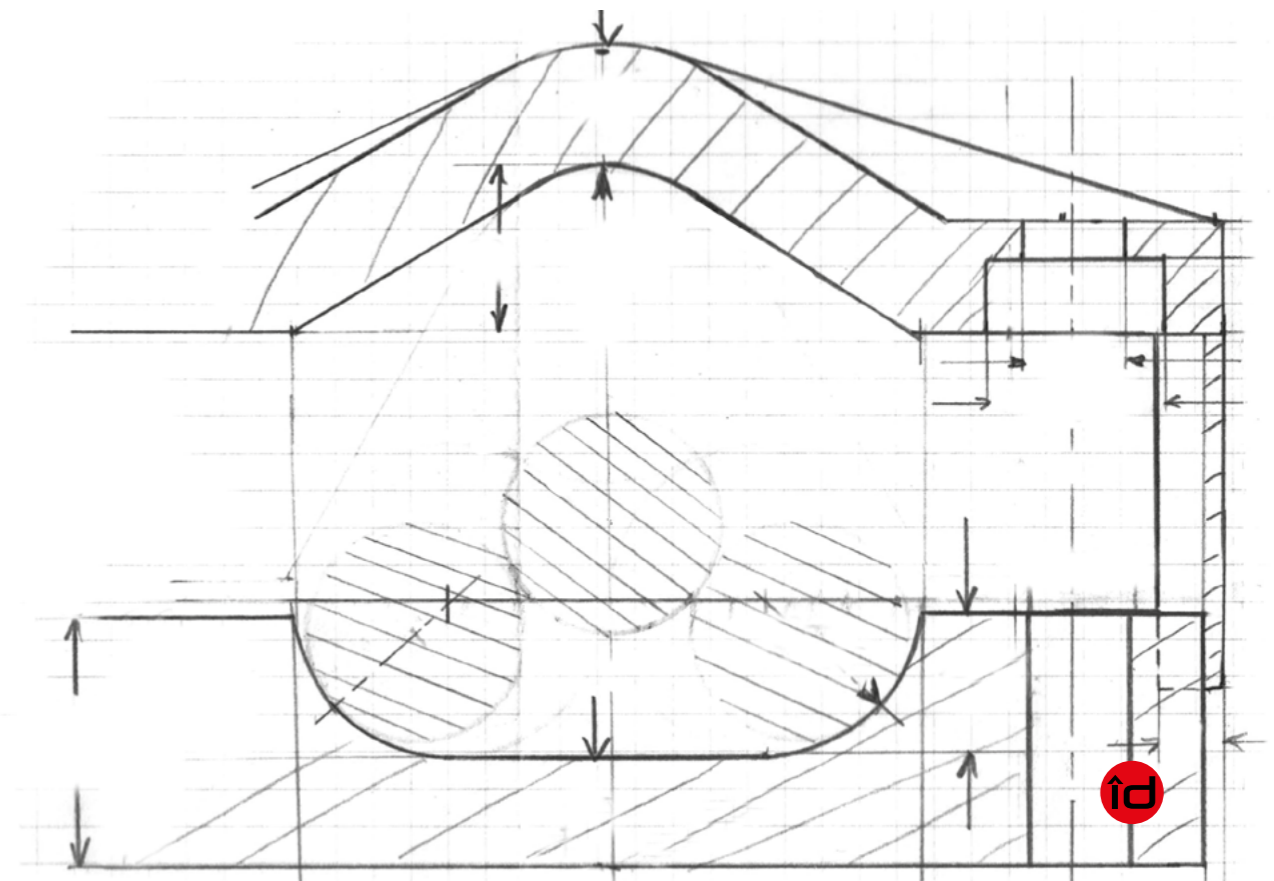



Company Profile	Page 6
Product Profile	Page 10
Planning	Page 14
Application Profile	Page 16
Service	Page 22
Customer-specific Items	Page 22
Cable Clamp Properties	Page 24

Cable Clamps for single fastening of single- and multi-core cables
(Also suitable for bundled fastening of multiple cables)

K Series	Dynamic resistance to short circuits: Outer cable diameter:	12.500 N 19 - 90 mm*	Page 26
K Series with factory fixed Elastic Inlays	Dynamic resistance to short circuits: Outer cable diameter:	12.500 N 19 - 84 mm*	Page 28
K-Tower Series	Dynamic resistance to short circuits: Outer cable diameter:	10.000 N 24 - 75 mm	Page 30
KT Series	Dynamic resistance to short circuits: Outer cable diameter:	25.000 N 19 - 39 mm*	Page 34
KT Series with factory fixed Elastic Inlays	Dynamic resistance to short circuits: Outer cable diameter:	25.000 N 19 - 36 mm*	Page 36
KR Series	Dynamic resistance to short circuits: Outer cable diameter:	30.000 N 70 - 250 mm*	Page 40

Cable Clamps for trefoil fastening of single- and multi-core cables

KS Series	Dynamic resistance to short circuits: Outer cable diameter:	13.000 N 22 - 46 mm*	Page 44
KS Series with factory fixed Elastic Inlays	Dynamic resistance to short circuits: Outer cable diameter:	13.000 N 22 - 43 mm*	Page 46
KP Series	Dynamic resistance to short circuits: Outer cable diameter:	25.000 N 26 - 64 mm*	Page 50
KP Series with factory fixed Elastic Inlays	Dynamic resistance to short circuits: Outer cable diameter:	25.000 N 26 - 61 mm*	Page 52
KH Series	Dynamic resistance to short circuits: Outer cable diameter:	30.000 N 59 - 165 mm*	Page 56

Cable Clamps for parallel fastening of single- and multi-core cables

RS Series	Dynamic resistance to short circuits: Outer cable diameter:	10.000 N 12 - 38 mm	Page 60
------------------	--	------------------------	---------

Mounting Examples	Page 63
Accessories for Cable Clamps	
Elastic Inlay for Fixation and Padding of Cables	Page 64
Distance Wedge for KH-Series	Page 66
Assembly Instructions Cable Clamps	Page 70
Explanatory Notes to IEC 61914	Page 81



The worldwide market leader in polyamide Cable Clamps for power cables



id-Technik Cable Clamps – for universal applications

Maximum resistance to short circuits for all voltage ranges and under the most extreme conditions

Usable anywhere id-Technik Cable Clamps guarantee the safe and reliable transmission of electricity in over 120 countries. They secure power cables under the most extreme conditions – in the heat of the desert, the cold of the poles, in aggressive chemical environments, on and offshore.

Across all product ranges, from high voltage to low voltage, each of our products is built on the same philosophy:

- Anything that is designed for the toughest applications and uncompromising short circuit resistance must be usable without ifs and buts and must prove its reliability over decades
- Certificates and continuous testing confirm this unique id-quality. Throughout our many years in the market, we are not aware that any id-Technik Cable Clamps in use have failed or become defective

Superior short circuit restraint for cables comes from our continuing design and development work

id-Technik Cable Clamps are 100% Made in Germany including product design, raw materials and fabrication. Our product range benefits from our wide-ranging expertise acquired through 40 years of cable clamping experience.

We are an owner-led technically focused company with an uncompromising goal of providing complete technical solutions for customer requirements. This traditional business philosophy ensures that there is never conflict between short-term business goals and our obligation to meet customer expectations. When it comes to technical perfection and quality, we do not compromise.

Our Cable Clamps are also used in your industry

Worldwide, our customers include major electrical companies, cable and switchgear manufacturers, installation companies, energy suppliers, utility companies and manufacturers of on and offshore wind farms. Beyond the energy industry, our products ensure reliable electrical installation in all sectors, from the transport industry, through chemical companies, to the mining, oil and gas industries, machine and automobile manufacturing and in cable, train and road tunnels.

You can therefore rest assured that our product portfolio already contains a solution that will cater to the particularities of your sector and the associated requirements. If not, we will sit down with you to develop a tailored solution that suits your needs. It is this combination of a comprehensive range of services and personal consultation that has made us into the global market leader in polyamide Cable Clamps.

Electricity always takes the shortest route – and our products do, too

We understand that the delivery of Cable Clamps can be critical for project schedules. We prioritize our delivery capabilities and pull out all the stops to ensure you receive your delivery quickly and directly – on the agreed day, at the specified location specified in 120 countries around the world.



- ✓ OVER 40 YEARS ON THE MARKET
- ✓ EXPORTS TO 120 COUNTRIES
- ✓ OVER 2000 CUSTOMERS
- ✓ 24 WORLDWIDE DISTRIBUTION LOCATIONS

- ✓ 100% MADE IN GERMANY
- ✓ 0 FAILURES IN 40+ YEARS
- ✓ APPLICATION FROM -60°C TO +120°C



**Our quality:
100% Made in Germany**



Technical advantages to benefit you

1 Universal range of application

id-Technik Cable Clamps are designed for use in all outdoor and indoor locations where power cables can be installed. The Clamps are designed to withstand the toughest environments and are resistant to UV radiation and exposure to chemicals. Ambient temperature ranges and other significant characteristics are clearly identified on each product. We welcome all opportunities to consult with end-users in order to develop cooperative solutions for specific installation challenges.

Our Clamps are being used under the most extreme conditions.

In regions with extreme climates, such as deserts, the tropics, high mountains, polar and coastal areas. In temperatures as low as -60°C. In sustained temperatures of up to 120°C. Subject to cyclical load changes. Under salt water, in atmospheres containing ozone and with radioactive radiation. Exposed to mineral oils, fuels, salts, alkaline solutions, alcohols, hydrocarbons, ketones, ether and termites.

2 Clear design, easy to use

All id-Technik Clamps are manufactured from a special, high-grade plastic (polyamide). Each Clamp consists of just two parts: an upper part and a lower part, which are secured together by fasteners that also provide the attachment to the structure. The lower part can be pre-installed for ease of installation. Thanks to the versatile range of attachment options, Clamp installation methods can be easily adapted to suit local circumstances.

With seven different product types, short circuit-proof clamping is possible for cables all voltage ranges with diameters between 19 mm and 250 mm.

3 Easy installation

No special tools are needed to install our Cable Clamps. Any competent electrical fitter will have the necessary expertise. id-Technik Cable Clamps are also easy to reuse after renovations or temporary use.

You only have to observe the tightening torque to be used on the fixing screws to protect the fragile cables.

A system you can rely on.

Each of our Cable Clamps can accommodate a wide range of cable diameters. Along with overlapping clamping ranges, this prevents assembly problems if cable diameters vary. Clamp variability also minimises your stock requirements, as you can cover all possible applications for your cable system using a few standard types.

4 Maintenance-free, even after multiple short circuits

Restraint of cable movement and the prevention of cable system component failure during short circuit events is critically important for power cable systems. They must be able to withstand repeated short circuit events without sustaining damage and be immediately available for full operation afterwards, without requiring maintenance or repair work. We achieve excellent dynamic resistance thanks to the advanced design and construction of our Cable Clamps and by using a polyamide, which has been specially developed to meet these requirements.

This means that your installation can withstand a high level of dynamic forces.

Our Clamps are specifically designed to restrain dynamic forces that develop within milliseconds and pulse at twice the fundamental frequency during short circuit current flow. The large clamping area minimises surface pressure and prevents damage to the cables, including in the event of a short circuit. Thanks to the special polyamide and the construction of the Cable Clamps, the tightening torques on the fixing screws are very low, thus avoiding any impact on the cable shape and construction.

Exhaustive testing at accredited test institutes has confirmed the dynamic resistance capabilities of our Clamps under realistic installation conditions and fault current levels.



5 More operational safety thanks to Elastic Inlays

Elastic Inlays are recommended for cables with an outer diameter of 60 mm or more. Our Elastic Inlays (EE) are designed to accommodate cable diameter changes resulting from variations in cable loading or ambient temperature. The Inlay compressibility prevents excessive pressure being applied to the cable jacket, avoiding jacket deformation or other types of jacket damage.

By increasing axial retention, they allow cables to be fixed precisely and securely for the long-term (from 120° to -60°C) and enable the absorption of weight forces, especially on cable ladders and vertical surfaces. The Elastic Inlays balance out the vibrations that occur in wind turbines, for example, without reducing the retention forces. They also permit the use of cables with a smaller outer diameter, as the Clamps' clamping area is expanded.

Elastic Inlays must be placed with the ribs parallel to the cable. To assist with installations on inclines, series K, KT, KS and KP Cable Clamps can be supplied with the Elastic Inlays fixed in our factory. This includes cutting the Elastic Inlays to size. To avoid negative impact on cable retention, Inlays should only be fixed by id-Technik. Inlays must not be fixed to the clamp using glue, silicone or paste during field installation. Any installation where inlays have been fixed using adhesives of any kind on site are not protected by our warranty.

6 Safety thanks to certified quality

id-Technik Cable Clamps are type-tested by accredited test institutes for the highest classification to the international standard IEC 61914.

Since 1998, our quality management system has regularly been certified to the current version of standard DIN EN ISO 9001.

7 Sustainability and environmental protection

The excellent material in id-Technik Clamps is non-toxic, not harmful to health, fully recyclable, self-extinguishing, low-smoke and zero halogen (LSZH). It is compliant with directive 2011/65/EU (RoHS) and regulation (EC) no. 1907/2006 (REACH regulation). Furthermore, it is non-metallic, non-magnetic and corrosion-resistant. It does not interact with the cable's electromagnetic field.

Unlike metal clamps, no additional polymer coating or similar is needed to protect the cable against mechanical damage. Our Cable Clamps do not need to be earthed.

PLANNING

Dimensioning a short circuit-resistant cable system

A cable system includes the following components:

- Cable
- Cable terminations
- Cable joints
- Cable Clamps
- Mounting hardware
- Cable racks
- Support systems

Each individual component must be capable to safely control the dynamic forces which occur during a short circuit.

The following factors should be considered when designing a cable support system:

- Peak short circuit current i_p [kA]
- Sustained short circuit current i''_k [kA]
- Operating voltage U_N [kV]
- Cable type, cable design, sectional view and maximum permitted deflection of the cable
- Maximum outer diameter of the cable [m]
- For single cable routing, the centre-to-centre distance of the cables [m]
- Distance between Cable Clamps [m]
- Length of the cable route [m]
- Dynamic short circuit resistance of the Cable Clamp [N]
- Dynamic resistance to short circuits of the substructure and of the fastening material [N]

Suitable separation between Cable Clamps depends on:

- Peak short circuit current
- Dynamic short circuit resistance of the Cable Clamp
- Cable design, including bending stiffness (bending modulus).

During short circuit events, sharp deflections of the cable must be avoided. If the maximum deflection of the cable is exceeded, it can be irreparably damaged and require complete replacement, including re-installation of the entire cable system.

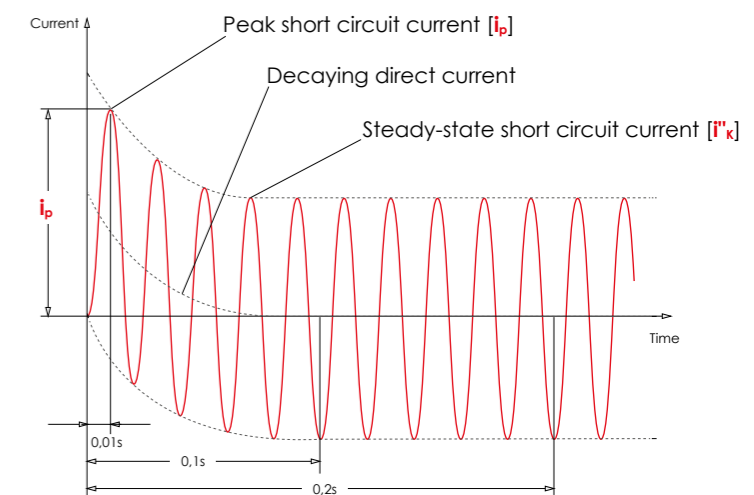

schematic diagram: short circuit current characteristic





Clarifying questions and selection

1 Type of fastening

- Single, trefoil, parallel, bundled or stacked installation of cables
- Single Clamps: K, KT or KR series
- Trefoil Clamps: KS, KP or KH series
- Parallel installation: RS series (of 3, 4 or 5 cables)
- Stacked installation: K, KR and RS series
- Bundling of multiple cables (including of different diameters): possible with all Cable Clamps

id-Technik will be happy to assist you in choosing the suitable Cable Clamps (e.g. including for bundling multiple cables in one Clamp).

2 Cable outer diameter

The Cable Clamps offer a clamping range for cable outer diameters of 19 mm to 250 mm. To enable simple allocation, the type descriptors are named according to their clamping range: e.g. K66/90 is suitable for cables with diameters between 66 mm and 90 mm and KH 115/140 is suitable for three cables, each with a diameter of 115 mm to 140 mm.

Neighbouring Clamps of each product series have overlapping diameter ranges, to ensure ease of use at the range limits. We recommend the application of the smallest suitable Clamp. The clamping area of each individual Clamp is deliberately kept wide. Thanks to the large cable diameter range of each

Clamp, a small number of different Cable Clamp types can cover a large range of cable diameters (including for different projects). This simplifies and reduces stock requirements, with the associated reduction in costs. It also makes planning and installation easier. In case of production related deviations in the cable diameter, the existing Clamp type can still be used. This avoids the need to re-determine and reorder other Cable Clamps (incl. the associated time delay).

Where there are overlaps between diameter ranges of different Clamp series, the short circuit dynamic resistance should be the primary selection factor.



Please note that the dynamic resistance to short circuits should not be confused with mechanical resistance.

Clarifying questions and selection

3 Max. peak short circuit current

The most important parameter in choosing a Clamp is the dynamic short circuit resistance provided. This determines whether the Clamp can restrain the dynamic forces that occur during a short circuit and protect the cable against damage. The entire cable system must be fully operational afterwards, without needing repair or maintenance.

Thanks to their excellent quality, îd-Technik Cable Clamps can withstand multiple short circuits.

Type-tested to the international standard IEC 61914, the product series have undergone several short circuit tests by an accredited test institute. In order to use realistic values, the short circuit tests were conducted with Cable Clamp separations and short circuit current values derived from practice. To simplify project planning, all Cable Clamps in a product series have the same dynamic resistance to short circuits.

Dynamic resistance [N] is the abruptly applied force that a Cable Clamp can resist. Due to the extreme magnetic field, short circuit forces occur within 1/100 of a second and pulse with a frequency of up to twice the fundamental frequency.

Mechanical resistance indicates the force [N] sustained during a static tensile test with no impulse forces present.

Static tensile tests do not permit conclusions to be drawn about the short circuit dynamic force restraint capabilities.

The dynamic resistance of a Cable Clamp to short circuits can only be proven through short circuit testing.

4 Use of Elastic Inlays "EE"

The use of the Elastic Inlay is particularly recommended for technical reasons in the following cases:

- As a cushion for accommodating cable diameter variations caused by changes in operational load and/or ambient temperature, in order to prevent excessive pressure and deformation or damage to the cable jackets. It is generally recommended for use with cable diameters of 60 mm or more
- Precise cable positioning and absorption of gravitational forces, for cables installed on inclines or attached to vertical surfaces, where restraint of axial movement is essential
- Dampening of vibrations, e.g. in wind turbines, without loss of cable holding capability
- Expansion of the Clamp's clamping area, for installation of cables that are at the low end of their diameter range

Clarifying questions and selection

Easy selection of the appropriate Cable Clamp for any application.

Type of fastening	Number of cables / Clamp	Cable Clamp series	Cable outer diameter [mm]*	Dynamic resistance to short circuits [N]**
Single	1	K	24-38	12.500
			36-52	
			50-75	
			66-90	
		KT	25-39	25.000
		KR	75-100	30.000
			100-130	
			130-160	
160-200				
Trefoil	3	KS	25-36	13.000
			33-46	
		KP	29-41	25.000
			39-53	
			51-64	
		KH	62-75	30.000
			73-86	
			84-97	
			95-107	
			105-117	
			115-140	
		138-165		
Parallel	3 - 5	RS	12-38	10.000
Stacked	(3-5 cables) x (2, 3,... layers)	RS	12-38	10.000
	2-3	K	24-38	10.000
			36-52	
			50-75	
Bundled	> 3	all	as above	acc. to series
Made to order	acc. to customer specification			

* Using the Elastic Inlay changes the Cable Clamp's clamping area. Diameter allocations can be found on the catalogue pages pertaining to the specific product series.
 ** Further explanations page 81 ff.

5 Mounting the Clamps

All id-Technik Clamps can be universally mounted in any direction (horizontally, vertically, hanging from the ceiling, attached to the side of a structure...). Screws attach directly to the substructure through the holes on both sides, taking into account the tightening torque indicated for the fastening material, which is specific to each series of Cable Clamps.

In the case of Clamps attached to a substructure, all of the dynamic forces during a short circuit are transferred to the structure. The substructure must be mechanically compatible with the Clamp's dynamic resistance capability.

id-Technik Cable Clamps are quick and simple to install, with no need for special tools. No extra adapter components are needed to install and assemble the Clamps. The mounting of Clamps can be adapted to local conditions and can also be carried out retroactively for cables, which have been laid already.

The Clamp construction minimizes surface pressure, thereby avoiding damage to the cable in case of a short circuit. The low tightening torque of the nuts (5 Nm - 8 Nm) on the upper part avoids cable damage or deformation but, due to the advanced design of the Clamp, guarantees that the cables are held securely.

Screw diameter	Max. height of the Clamp [mm]	Height of washer and nut [mm]	Additional length depending on dimension of substructure [mm]	Screw length [mm]
M 10	Max. value of H_1^* (rounded up)	+ 10	+ x	$H_1 + 10 + x$
M 12	Max. value of H_1^* (rounded up)	+ 15	+ x	$H_1 + 15 + x$
M 16	Max. value of H_1^* (rounded up)	+ 20	+ x	$H_1 + 20 + x$

* H_1 varies depending on the cable outer diameter.

6 Selection of fastening material:

Material and corrosion resistance:
 the choice of material for the fasteners is dependent on the installation environment and operating conditions (e.g. galvanised, stainless steel, etc.), strength grade 4.8 - 8.8

Type of screw:
 depends on the substructure (e.g. hexagon screws, T-head screws, threaded rod, etc.); not included in delivery

Fastener diameter:
 depends on the Cable Clamp (dimension: screw thread, which are shown in this catalogue)

Fastener Length:
 depends on the Cable Clamp (dimension H_1), the cable outer diameter and type of substructure

Only flat washers may be used. No spring or snap rings!

Do not use self-securing/self-locking nuts, this prohibits a defined tightening torque.

The appropriate clamping separation requires knowledge of the peak short circuit current and the dynamic resistance of the Cable Clamps.

Efficient installation without special tools and adapter components.

Service

In our direct product portfolio you will find Clamps for power cables of all voltages. The diameters range from 24 mm to 250 mm. With our Elastic Inlay you can also secure thinner cables (down to 19 mm).

We deliver all id-Technik products quickly and reliably, in the usual quantities. If you have questions about particular applications or installation, you can rely on the support of our technical department.

An overview of our product ranges:

- Single Clamps for fastening of one cable
- Trefoil Clamp to secure three cables
- Block Clamps and stacked Clamps to secure cables in parallel formation
- Bundling of multiple cables (including of different diameters) in one Cable Clamp

Customer-specific items made to order

Naturally, we develop solutions which are tailored/customised to you – just contact us.

If you do not find a Cable Clamp to suit your application in our comprehensive range of products, we are happy to advise you and develop a suitable solution which meets your requirements and technical specifications.

RS-Clamps can also be supplied for other diameter ranges, distances, cable arrangements and outer dimensions.

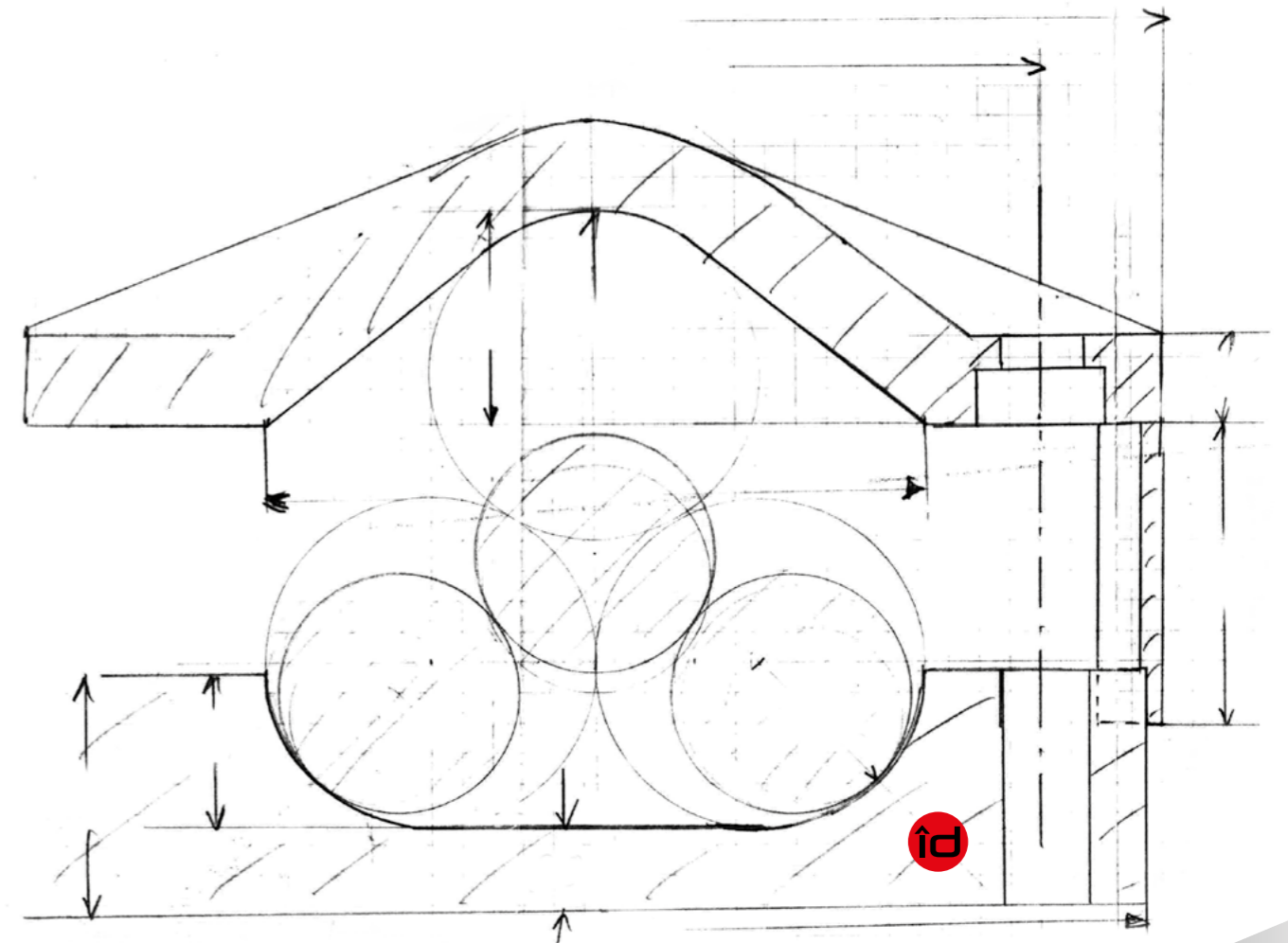
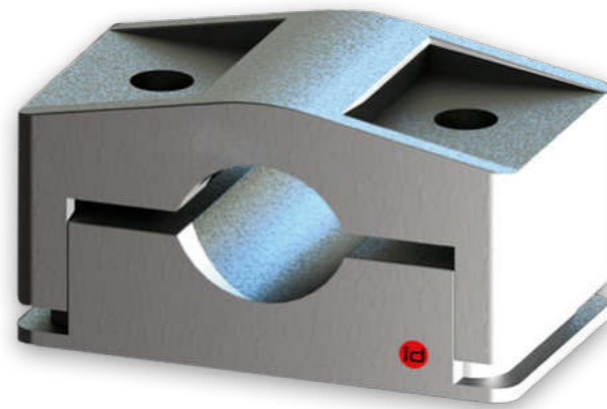

When it comes to technical perfection and quality, we do not compromise.



Technical details

Application

- Short circuit resistant fastening of all types of single and multi-core cables from extra high to low voltage
- Single, trefoil, parallel, bundled or stacked fastening of energy cables

Material

High-grade polyamide, fibreglass-reinforced, coloured black, with special UV protection, fully recyclable, self-extinguishing, low-smoke, zero halogen (LSZH), non-toxic, non-corrosive, non-metallic, non-magnetic

Properties

Resistance to

Ultraviolet rays, ozone, mineral oils, fuels, salts, alkalis, alcohol, hydrocarbons, ketones, ether, termites and radioactive rays*

Flame resistance

UL 94 5 VA (IEC 60695-11-20)
500 Watt flame test method

UL 94 V-0 (IEC 60695-11-10)
50 Watt flame test method

IEC 61914 following IEC 60695-11-5
Needle-flame test method

Classification following DIN 5510,
part 2: flammability class S3

Thermal expansion
0,01 % per 10°C temperature increase

Tensile strength
120 N/mm²

Flexural strength
210 N/mm²

Resistance to impact
Very heavy, type-tested to IEC 61914,
at -60°C

Lateral load test
Type-tested to IEC 61914, in x- and
y-direction, at 120°C

Axial load test [N]
Type-tested to IEC 61914, at 120°C

Dynamic resistance to short circuits
Type-tested to IEC 61914, suitable to with-
stand multiple short circuits

Temperature range

Ambient temperatures
down to -60°C*

Continuous operation
up to 120°C

Permitted short-term heating
up to 220°C

Operation life
more than 40 years of maintenance- and
failure-free operation

Legislation

Legal compliance

- Directive 2002/95/EG (RoHS)
- Regulation (EG) Nr. 1907/2006 (REACH regulation)

IEC 61914 STANDARD

îd-Technik Cable Clamps have been
type-tested by accredited test institutes to
the international standard IEC 61914.

Constructional features

- Particularly high dynamic and mechanical strength and heat resistance due to special fibreglass-reinforced polyamide
- Safe restraint of dynamic forces of high short circuit currents, without damage to the cables, also for multiple short circuits
- Type-tested to IEC 61914 – cable cleats for electrical installations - reports from accredited institutes regarding dynamic short circuit currents, the fire-resistance of the material, and mechanical properties of the Cable Clamps are available
- Very low surface pressure on cables due to Cable Clamps' large contact area
- Unrestricted application both indoor and outdoor in extreme climates such as deserts, tropics, high altitudes, arctic climate, coastal salt fogs, flooding, ozone due to special resistance to ageing, ultraviolet rays and ozone
- Easy to mount without special instruments and maintenance-free
- Fastening of Cable Clamps adaptable to all local conditions





100%
MADE IN
GERMANY

K SERIES

PROPERTIES

Resistance to: Ultraviolet rays, ozone, mineral oils, fuels, salts, alkalis, alcohol, hydrocarbons, ketones, ether, termites and radioactive rays*

Flame resistance: UL94 5VA (IEC 60695-11-20)
UL94 V-0 (IEC 60695-11-10)
IEC 61914 following IEC 60695-11-5
Classification following DIN 5510, part 2 Flammability class: S3

Thermal expansion: 0.01% per 10°C temperature increase

Tensile strength: 120 N/mm²

Flexural strength: 210 N/mm²

TEMPERATURE RANGE

Ambient temperature: down to -60°C*

Continuous operation: up to 120°C

Permitted short-term heating: up to 220°C

Operation life: more than 40 years of maintenance- and failure-free operation

MATERIAL

High-grade polyamide, fibreglass-reinforced, coloured black, with special UV protection, fully recyclable, self-extinguishing, low-smoke, zero halogen (LSZH), non-toxic, non-corrosive, non-metallic, non-magnetic

Applications:

Fastening of single- and multi-core cables. Unrestricted application indoors and outdoors between -60°C and +120°C. Fastening of energy cables in single, parallel, stacked and bundled formation.

Outer diameter of cables:

19 mm to 90 mm

Dynamic resistance to short circuits:

12.500 N

Tightening Torque for fixing material:

Upper part: 5 Nm**

Lower part: 20 Nm

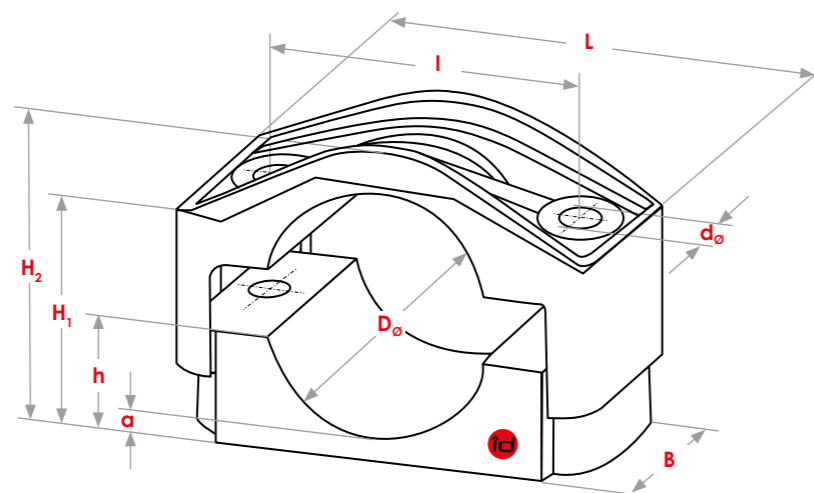

Dimensions in mm

Type	D ₀	D ₀₊	D ₀₊₊	L	B	I	H ₁	H ₂	h	a	d ₀	Screw thread
K 26/38	24-38	21-35	19-32	91	60	60	34-48	46-60	19	7	12	M10/12
K 36/52	36-52	33-49	30-46	108	60	75	43-59	56-72	24	8	12	M10/12
K 50/75	50-75	47-72	44-69	126	60	95	52-77	74-99	30	9	12	M10/12
K 66/90	66-90	63-87	60-84	158	70	120	65-89	91-115	42	10	14	M12

D₀: Outer cable diameter

D₀₊: ~ with one Elastic Inlay

D₀₊₊: ~ with two Elastic Inlays

* For more information contact id-Technik, please.

** Contact id-Technik for trailing cables (EPDM, rubber, etc.), please.

Standard IEC 61914 id-Technik Cable Clamps have been type-tested by accredited test institutes to the international standard IEC 61914.



Legal compliance

- Directive 2011/65/EU (RoHS)
- Regulation (EC) No. 1907/2006 (REACH regulation)

Constructional features

- Particularly high dynamic and mechanical strength and heat resistance due to special fibreglass-reinforced polyamide
- Safe restraint of dynamic forces of high short circuit currents, without damage to the cables, also for multiple short circuits
- Type-tested to IEC 61914 – cable cleats for electrical installations - reports from accredited institutes regarding dynamic short circuit currents, the fire-resistance of the material, and mechanical properties of the Cable Clamps are available
- Very low surface pressure on cables due to Cable Clamps' large contact area
- Unrestricted application both indoor and outdoor in extreme climates such as deserts, tropics, high altitudes, arctic climate, coastal salt fogs, flooding and ozone due to special resistance to ageing, ultraviolet rays and ozone
- Easy to mount without special instruments and maintenance-free
- Fastening of Cable Clamps adaptable to all local conditions

Type-Tests to IEC 61914 on Series K Cable Clamps approved results in highest classification

Classification	Test conditions	Approved results	Paragraph
Material: non-metallic	high-grade polyamide		6.1.2
Operating temperature	-60°C / +120°C	passed	6.2
Resistance to impact	-60°C, 5 kg at 400 mm height	very heavy	6.3.5
Lateral load test [N] – in x-direction – in y-direction	At +120°C	10.000 N 19.000 N	6.4.1
Axial load test [N] – without Elastic Inlays – with Elastic Inlays	At +120°C	600 N 800 N	6.4.2
Resistance to electrodynamic forces [N] suited to withstand multiple short circuits	Peak short circuit current: 109 kA Cable Clamp spacing: 1,11 m	12.500 N	6.4.4
UV-resistance	high	passed	6.5.1
Flame propagation	1 x 30s, needle flame method	passed	10.1 (IEC 60695-11-5)
	2 x 10s, 50 W test flame method	V-0	UL 94 V (IEC 60695-11-10)
	5 x 5s, 500 W test flame method	5VA	UL 94 5V (IEC 60695-11-20)
	3 min	S3	DIN 5510

Use of Elastic Inlays:

- As a cushion for elastic adjustment of cable diameter changes due to operational load changes and/or changes in the ambient temperature
- Precise cable fixation and absorption of weight forces, primarily on cables installed along inclines or attached to vertical surfaces where restraint of axial movement is essential
- Compensation of vibrations, e.g. in wind turbines, without reducing retention forces
- Expansion of the Clamp's clamping area, for cables with a smaller outer diameter

CABLE CLAMPS



K SERIES

 with factory fixed Elastic Inlays (EE)

100%
MADE IN
GERMANY

PROPERTIES

Resistance to: Ultraviolet rays, ozone, mineral oils, fuels, salts, alkalis, alcohol, hydrocarbons, ketones, ether, termites and radioactive rays*

Flame resistance: UL94 5VA (IEC 60695-11-20)
UL94 V-0 (IEC 60695-11-10)
IEC 61914 following IEC 60695-11-5
Classification following DIN 5510, part 2 Flammability class: S3

Thermal expansion: 0.01% per 10°C temperature increase

Tensile strength: 120 N/mm²

Flexural strength: 210 N/mm²

TEMPERATURE RANGE

Ambient temperature: down to -60°C*

Continuous operation: up to 120°C

Permitted short-term heating: up to 220°C

Operation life: more than 40 years of maintenance- and failure-free operation

MATERIAL

High-grade polyamide, fibreglass-reinforced, coloured black, with special UV protection, fully recyclable, self-extinguishing, low-smoke, zero halogen (LSZH), non-toxic, non-corrosive, non-metallic, non-magnetic

Applications:

Fastening of single- and multi-core cables. Unrestricted application indoors and outdoors between -60°C and +120°C. Fastening of energy cables in single, parallel, stacked and bundled formation.

Outer diameter of cables: 19 mm to 84 mm

Dynamic resistance to short circuits: 12,500 N

Tightening Torque for fixing material:

Upper part: 5 Nm** / Lower part: 20 Nm

Material Elastic Inlays: EPDM, one-side ribbed

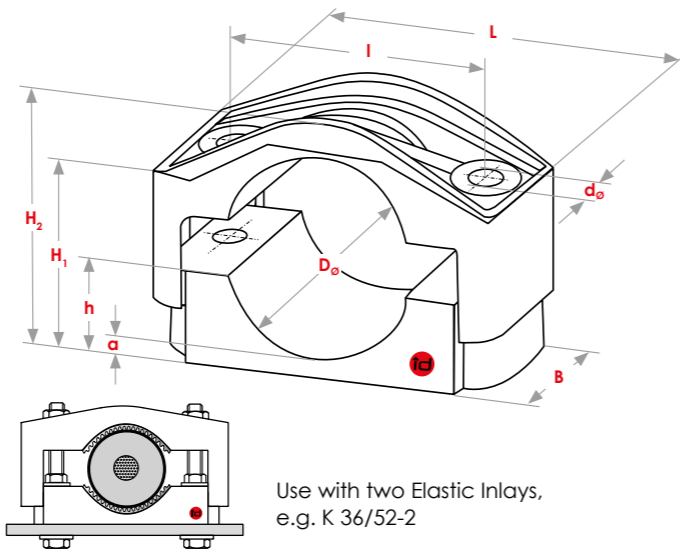

Dimensions in mm

Type	D ₀₊	D ₀₊₊	L	B	I	H ₁	H ₂	h	a	d ₀	Screw thread
K 26/38-1	21-35	-	91	60	60	34-48	46-60	19	7	12	M10/12
K 26/38-2	-	19-32									
K 36/52-1	33-49	-	108	60	75	43-59	56-72	24	8	12	M10/12
K 36/52-2	-	30-46									
K 50/75-1	47-72	-	126	60	95	52-77	74-99	30	9	12	M10/12
K 50/75-2	-	44-69									
K 66/90-1	63-87	-	158	70	120	65-89	91-115	42	10	14	M12
K 66/90-2	-	60-84									

D₀₊: ~ with one Elastic Inlay
D₀₊₊: ~ with two Elastic Inlays

* For more information contact id-Technik, please.
** Contact id-Technik for trailing cables (EPDM, rubber, etc.), please.



CABLE CLAMPS



K-Tower

SERIES

100%
MADE IN
GERMANY

PROPERTIES

Resistance to:	Ultraviolet rays, ozone, mineral oils, fuels, salts, alkalis, alcohol, hydrocarbons, ketones, ether, termites and radioactive rays*
Flame resistance:	UL94 5VA (IEC 60695-11-20) UL94 V-0 (IEC 60695-11-10) IEC 61914 following IEC 60695-11-5 Classification following DIN 5510, part 2 Flammability class: S3
Thermal expansion:	0.01% per 10°C temperature increase
Tensile strength:	120 N/mm ²
Flexural strength:	210 N/mm ²

TEMPERATURE RANGE

Ambient temperature:	down to -60°C*
Continuous operation:	up to 120°C
Permitted short-term heating:	up to 220°C
Operation life:	more than 40 years of maintenance- and failure-free operation

MATERIAL

High-grade polyamide, fibreglass-reinforced, coloured black, with special UV protection, fully recyclable, self-extinguishing, low-smoke, zero halogen (LSZH), non-toxic, non-corrosive, non-metallic, non-magnetic

Applications:

For stacking, fastening of single- and multi-conductor cables unrestricted application indoors and outdoors between -60°C and +120°C.

Outer diameter of cables:

24 mm to 75 mm

Dynamic resistance to short circuits:

10.000 N

Tightening Torque for fixing material:

Lowest bottom part: 20 Nm
All other parts: 5 Nm**

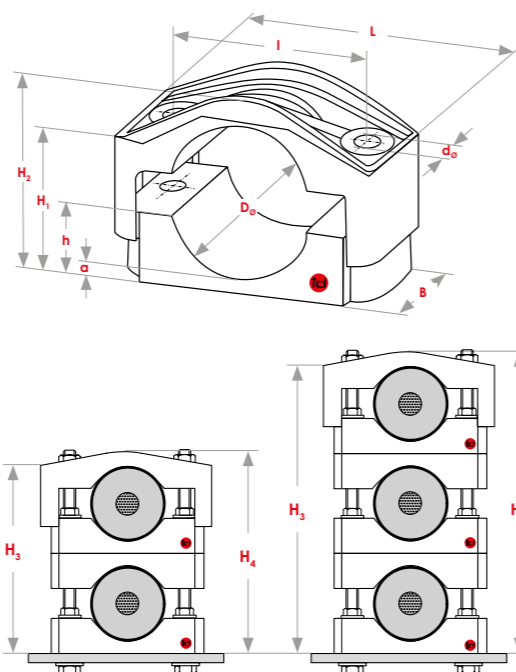

Dimensions in mm

Type	D ₀	L	B	I	H ₁	H ₂	H ₃	H ₄	h	a	d ₀	Screw thread
Double Tower K 26/38	24-38	91	60	60	34-48	46-60	73-101	85-113	19	7	12	M10
Triple Tower K 26/38							112-154	124-168				
Double Tower K 36/52	36-52	108	60	75	43-59	56-72	96-128	109-141	24	8	12	M10
Triple Tower K 36/52							149-197	162-210				
Double Tower K 50/75	50-75	126	60	95	52-77	74-99	128-178	150-200	30	9	12	M10
Triple Tower K 50/75							204-279	226-301				

D₀: Outer cable diameter

* For more information contact id-Technik, please.

** Contact id-Technik for trailing cables (EPDM, rubber, etc.), please.



100%
MADE IN
GERMANY

K SERIES

EXAMPLES OF MOUNTING METHODS

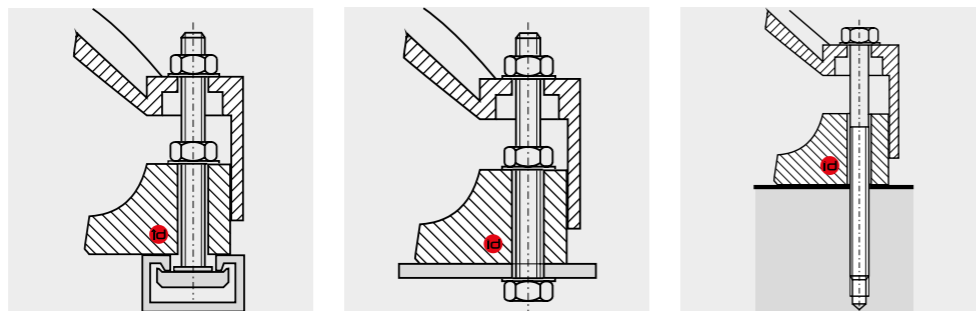

▲ Mounting types

► Bundling:

Also suitable for bundled installation of multiple cables (including of different diameters)

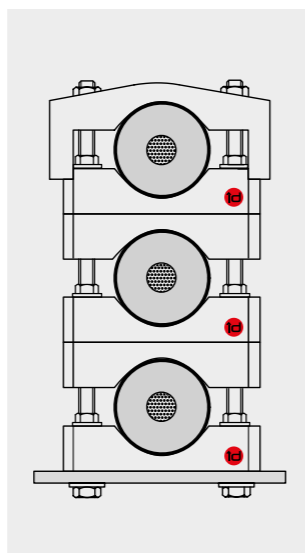
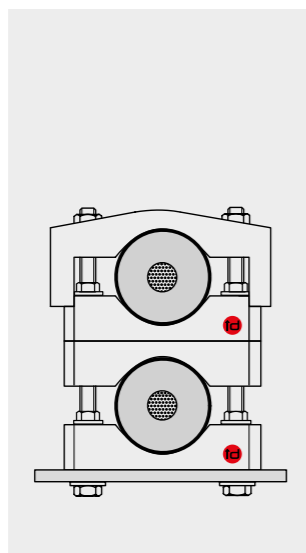
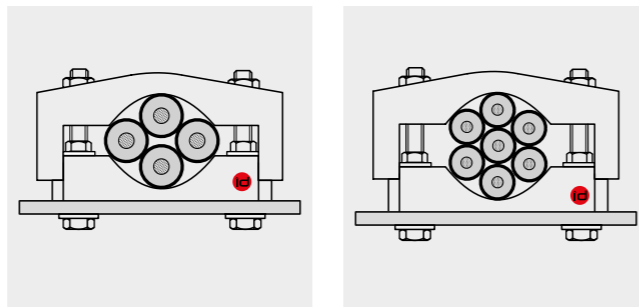

◀ Double Tower left:

1 complete Clamp (= 1 upper part + 1 lower part) plus 2 additional lower parts

Triple Tower right:

1 complete Clamp (= 1 upper part + 1 lower part) plus 4 additional lower parts

Multiple systems can be secured parallel with several towers next to each other.

1

UNIVERSAL MOUNTING OPTIONS

adaptable to local conditions

EASY TO MOUNT

respecting the tightening torques of the fastening material

2

3

MAINTENANCE-FREE

more than 40 years of maintenance- and failure-free operation

▼ Use with one Elastic Inlay e.g. K 26/38-1

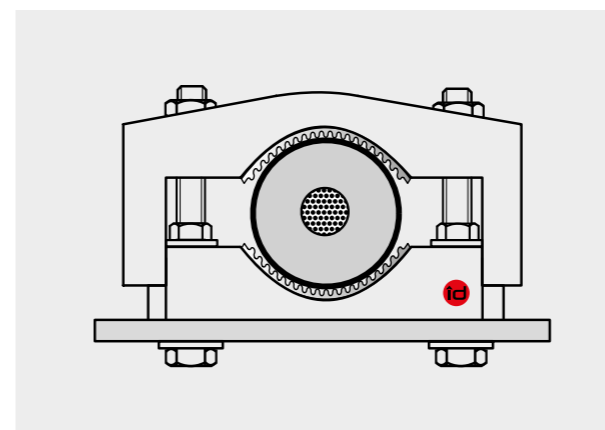
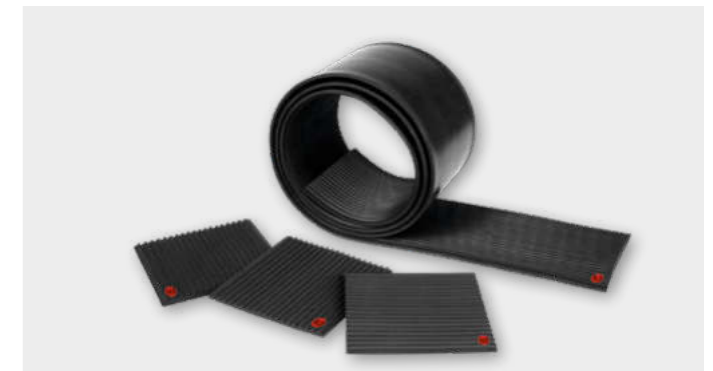
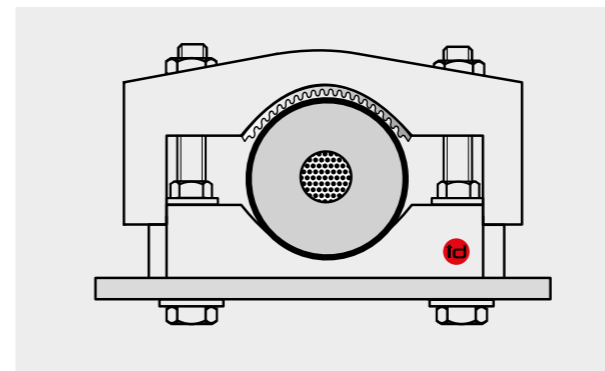

▲ Use with two Elastic Inlays, e.g. K 36/52-2

The Elastic Inlays must ONLY be inserted into the id-Technik Clamps, not fixed, with the ribs running parallel to the cable lengthways.

To assist with mounting, Cable Clamps can be supplied with the Elastic Inlays cut to size and fixed in our factory. To avoid negative impact on the retention, the Elastic Inlays should ONLY be fixed by id-Technik.

The guarantee expires immediately if any form of adhesive eg. glue, silicone or paste is applied during installation of the clamps on site. Elastic Inlay must retain its full flexibility when used.

Torque for tightening the fastening material:
Lowest bottom part:
20 Nm
All other parts:
5 Nm*

* Contact id-Technik for trailing cables (EPDM, rubber, etc.), please.



**100%
MADE IN
GERMANY**

KT SERIES

PROPERTIES

Resistance to: Ultraviolet rays, ozone, mineral oils, fuels, salts, alkalis, alcohol, hydrocarbons, ketones, ether, termites and radioactive rays*

Flame resistance: UL94 5VA (IEC 60695-11-20)
UL94 V-0 (IEC 60695-11-10)
IEC 61914 following IEC 60695-11-5
Classification following DIN 5510, part 2 Flammability class: S3

Thermal expansion: 0.01% per 10°C temperature increase

Tensile strength: 120 N/mm²

Flexural strength: 210 N/mm²

TEMPERATURE RANGE

Ambient temperature: down to -60°C*

Continuous operation: up to 120°C

Permitted short-term heating: up to 220°C

Operation life: more than 40 years of maintenance- and failure-free operation

MATERIAL

High-grade polyamide, fibreglass-reinforced, coloured black, with special UV protection, fully recyclable, self-extinguishing, low-smoke, zero halogen (LSZH), non-toxic, non-corrosive, non-metallic, non-magnetic

Applications:

Fastening of single- and multi-core cables, for high short circuit fores. Unrestricted application indoors and outdoors between -60°C and +120°C. Fastening of energy cables in single, parallel, stacked and bundled formation.

Outer diameter of cables:
19 mm to 39 mm

Dynamic resistance to short circuits:
25.000 N

Tightening Torque for fixing material:
Upper part: 5 Nm**
Lower part: 20 Nm

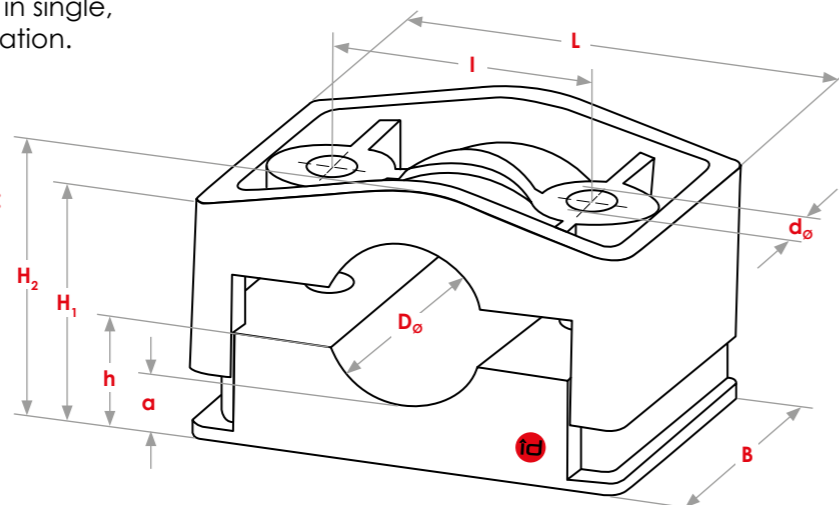

Dimensions in mm

Type	D ₀	D ₀₊	D ₀₊₊	L	B	I	H ₁	H ₂	h	a	d ₀	Screw thread
KT 25/39	25-39	22-36	19-33	107	60	65	46-60	55-69	27	15	13	M12

D₀: Outer cable diameter
D₀₊: ~ with one Elastic Inlay
D₀₊₊: ~ with two Elastic Inlays

* For more information contact id-Technik, please.
** Contact id-Technik for trailing cables (EPDM, rubber, etc.), please.

Standard IEC 61914 id-Technik Cable Clamps have been type-tested by accredited test institutes to the international standard IEC 61914.

Legal compliance

- Directive 2011/65/EU (RoHS)
- Regulation (EC) No. 1907/2006 (REACH regulation)

Constructional features

- Particularly high dynamic and mechanical strength and heat resistance due to special fibreglass-reinforced polyamide
- Safe restraint of dynamic forces of high short circuit currents, without damage to the cables, also for multiple short circuits
- Type-tested to IEC 61914 – cable cleats for electrical installations - reports from accredited institutes regarding dynamic short circuit currents, the fire-resistance of the material, and mechanical properties of the Cable Clamps are available
- Very low surface pressure on cables due to Cable Clamps' large contact area
- Unrestricted application both indoor and outdoor in extreme climates such as deserts, tropics, high altitudes, arctic climate, coastal salt fogs, flooding and ozone due to special resistance to ageing, ultraviolet rays and ozone
- Easy to mount without special instruments and maintenance-free
- Fastening of Cable Clamps adaptable to all local conditions

Type-Tests to IEC 61914 on Series KT Cable Clamps approved results in highest classification

Classification	Test conditions	Approved results	Paragraph
Material: non-metallic	high-grade polyamide		6.1.2
Operating temperature	-60°C / +120°C	passed	6.2
Resistance to impact	-60°C, 5 kg at 400 mm height	very heavy	6.3.5
Lateral load test [N] – in x-direction – in y-direction	+120°C	20.000 N 30.000 N	6.4.1
Axial load test [N] – without Elastic Inlays – with Elastic Inlays	+120°C	600 N 800 N	6.4.2
Dynamic resistance to short circuits [N] suited to withstand multiple short circuits	Peak short circuit current: 151 kA Cable Clamp spacing: 0,84 m	25.000 N	6.4.4
UV-resistance	high	passed	6.5.1
Flame propagation	1 x 30s, needle flame method	passed	10.1 (IEC 60695-11-5)
	2 x 10s, 50 W test flame method	V-0	UL 94 V (IEC 60695-11-10)
	5 x 5s, 500 W test flame method	5VA	UL 94 5V (IEC 60695-11-20)
	3 min	S3	DIN 5510

Use of Elastic Inlays:

- As a cushion for elastic adjustment of cable diameter changes due to operational load changes and/or changes in the ambient temperature
- Precise cable fixation and absorption of weight forces, primarily on cables installed along inclines or attached to vertical surfaces where restraint of axial movement is essential
- Compensation of vibrations, e.g. in wind turbines, without reducing retention forces
- Expansion of the Clamp's clamping area, for cables with a smaller outer diameter



100%
MADE IN
GERMANY

KT SERIES with factory fixed Elastic Inlays (EE)

PROPERTIES

- Resistance to:** Ultraviolet rays, ozone, mineral oils, fuels, salts, alkalis, alcohol, hydrocarbons, ketones, ether, termites and radioactive rays*
- Flame resistance:** UL94 5VA (IEC 60695-11-20)
UL94 V-0 (IEC 60695-11-10)
IEC 61914 following IEC 60695-11-5
Classification following DIN 5510, part 2 Flammability class: S3
- Thermal expansion:** 0.01% per 10°C temperature increase
- Tensile strength:** 120 N/mm²
- Flexural strength:** 210 N/mm²

TEMPERATURE RANGE

- Ambient temperature:** down to -60°C*
- Continuous operation:** up to 120°C
- Permitted short-term heating:** up to 220°C
- Operation life:** more than 40 years of maintenance- and failure-free operation

MATERIAL

High-grade polyamide, fibreglass-reinforced, coloured black, with special UV protection, fully recyclable, self-extinguishing, low-smoke, zero halogen (LSZH), non-toxic, non-corrosive, non-metallic, non-magnetic

Applications:

Fastening of single- and multi-core cables for high short circuit fores. Unrestricted application indoors and outdoors between -60°C and +120°C. Fastening of energy cables in single, parallel, stacked and bundled formation.

Outer diameter of cables:
19 mm to 36 mm

Dynamic resistance to short circuits:
25.000 N

Tightening Torque for fixing material:
Upper part: 5 Nm** / Lower part: 20 Nm

Material Elastic Inlay:
EPDM, one-side ribbed

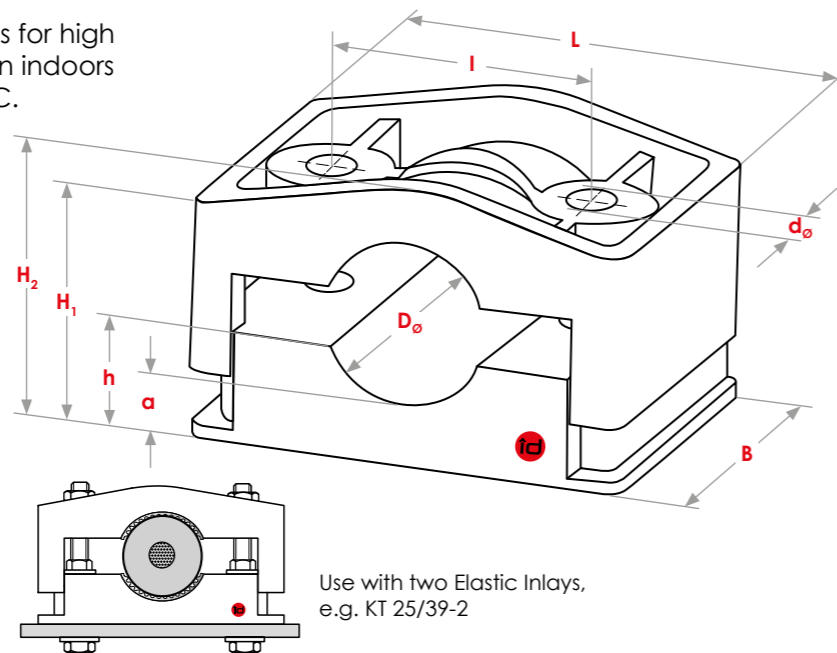

Dimensions in mm

Type	D ₀₊	D ₀₊₊	L	B	I	H ₁	H ₂	h	a	d ₀	Screw thread
KT 25/39-1	22 - 36	-	107	60	65	46-60	55-69	27	15	13	M12
KT 25/39-2	-	19-33	107	60	65	46-60	55-69	27	15	13	M12

D₀: Outer cable diameter
D₀₊: ~ with one Elastic Inlay
D₀₊₊: ~ with two Elastic Inlays

* For more information contact id-Technik, please.
** Contact id-Technik for trailing cables (EPDM, rubber, etc.), please.





100%
MADE IN
GERMANY

KT SERIES

EXAMPLES OF MOUNTING METHODS

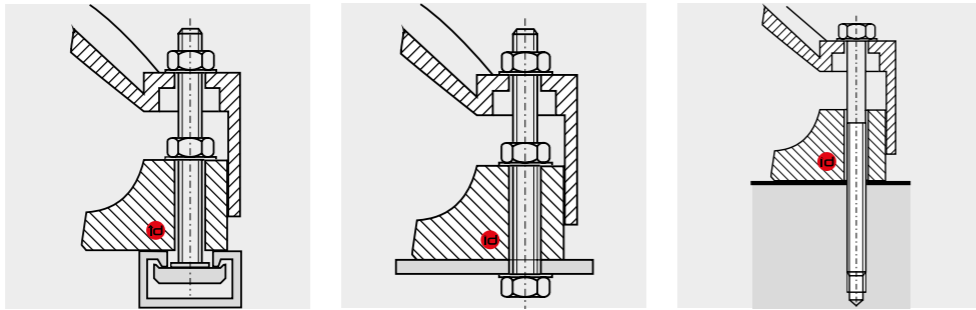

▲ Mounting types



Torque for tightening the fastening material:
Upper part: 5 Nm*
Lower part: 20 Nm

1 **UNIVERSAL MOUNTING OPTIONS**
adaptable to local conditions

EASY TO MOUNT
respecting the tightening torques of the fastening material

2

3 **MAINTENANCE-FREE**
more than 40 years of maintenance- and failure-free operation

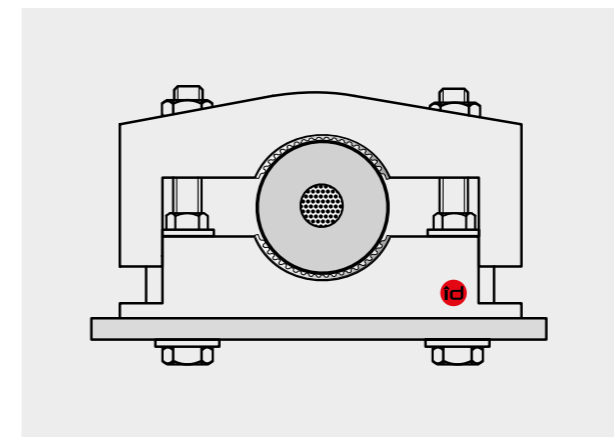
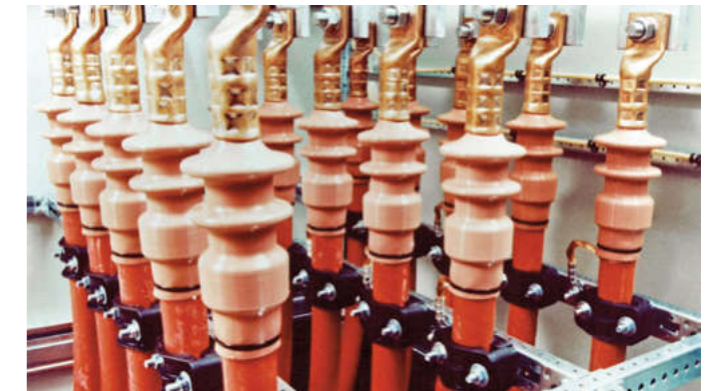
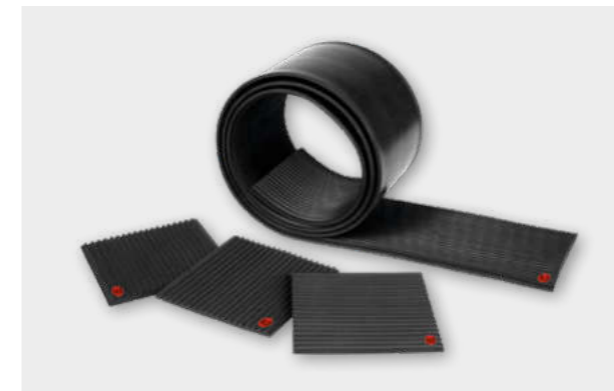

The Elastic Inlays must **ONLY** be inserted into the id-Technik Clamps, not fixed, with the ribs running parallel to the cable lengthways.

To assist with mounting, Cable Clamps can be supplied with the Elastic Inlays cut to size and fixed in our factory. To avoid negative impact on the retention, the Elastic Inlays should **ONLY** be fixed by id-Technik.

The guarantee expires immediately if any form of adhesive eg. glue, silicone or paste is applied during installation of the clamps on site. Elastic Inlay must retain its full flexibility when used.

▲ Use with two Elastic Inlays, e.g. KT 25/39-2



KR SERIES

100%
MADE IN
GERMANY

PROPERTIES

- Resistance to:** Ultraviolet rays, ozone, mineral oils, fuels, salts, alkalis, alcohol, hydrocarbons, ketones, ether, termites and radioactive rays*
- Flame resistance:** UL94 5VA (IEC 60695-11-20)
UL94 V-0 (IEC 60695-11-10)
IEC 61914 following IEC 60695-11-5
Classification following DIN 5510, part 2 Flammability class: S3
- Thermal expansion:** 0.01% per 10°C temperature increase
- Tensile strength:** 120 N/mm²
- Flexural strength:** 210 N/mm²

TEMPERATURE RANGE

- Ambient temperature:** down to -60°C*
- Continuous operation:** up to 120°C
- Permitted short-term heating:** up to 220°C
- Operation life:** more than 40 years of maintenance- and failure-free operation

MATERIAL

High-grade polyamide, fibreglass-reinforced, coloured black, with special UV protection, fully recyclable, self-extinguishing, low-smoke, zero halogen (LSZH), non-toxic, non-corrosive, non-metallic, non-magnetic

Applications:

Fastening of single- and multi-core cables for high short circuit fores. Unrestricted application indoors and outdoors between -60°C and +120°C. Fastening of energy cables in single, parallel, stacked and bundled formation.

Outer diameter of cables:
70 mm to 250 mm

Dynamic resistance to short circuits:
30.000 N

Tightening Torque for fixing material:
Upper part: 8 Nm** / Lower part: 20 Nm

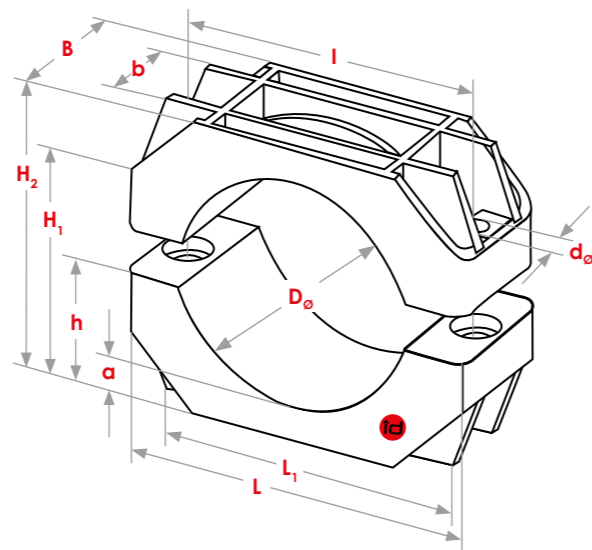

Dimensions in mm

Type	D ₀	D ₀₊₊	L	L ₁	B	b	I	H ₁	H ₂	h	a	d ₀	Screw thread
KR 75/100	75-100	70-95	180	172	77	44	150	71-97	109-134	52	17	14	M12
KR 100/130	100-130	95-125	210	197	97	54	175	99-129	140-170	69	20	14	M12
KR 130/160	130-160	125-155	250	213	97	54	210	116-146	176-206	87	23	18	M16
KR 160/200	160-200	155-195	290	258	120	60	250	172-212	230-270	113	35	18	M16
KR 200/250	200-250	195-245	340	300	120	61	300	190-240	280-330	130	40	18	M16

D₀: Outer cable diameter
D₀₊₊: ~ with two Elastic Inlays

* For more information contact id-Technik, please.
** Contact id-Technik for trailing cables (EPDM, rubber, etc.), please.

Standard IEC 61914 id-Technik Cable Clamps have been type-tested by accredited test institutes to the international standard IEC 61914.

Legal compliance

- Directive 2011/65/EU (RoHS)
- Regulation (EC) No. 1907/2006 (REACH regulation)

Constructional features

- Particularly high dynamic and mechanical strength and heat resistance due to special fibreglass-reinforced polyamide
- Safe restraint of dynamic forces of high short circuit currents, without damage to the cables, also for multiple short circuits
- Type-tested to IEC 61914 – cable cleats for electrical installations - reports from accredited institutes regarding dynamic short circuit currents, the fire-resistance of the material, and mechanical properties of the Cable Clamps are available
- Very low surface pressure on cables due to Cable Clamps' large contact area
- Unrestricted application both indoor and outdoor in extreme climates such as deserts, tropics, high altitudes, arctic climate, coastal salt fogs, flooding and ozone due to special resistance to ageing, ultraviolet rays and ozone
- Easy to mount without special instruments and maintenance-free
- Fastening of Cable Clamps adaptable to all local conditions

Type-Tests to IEC 61914 on Series KR Cable Clamps approved results in highest classification

Classification	Test conditions	Approved results	Paragraph
Material: non-metallic	high-grade polyamide		6.1.2
Operating temperature	-60°C / +120°C	passed	6.2
Resistance to impact	-60°C, 5 kg at 400 mm height	very heavy	6.3.5
Lateral load test [N] – in x-direction – in y-direction	+120°C	18.000 N 15.000 N	6.4.1
Axial load test [N] – with Elastic Inlays	+120°C	1.500 N	6.4.2
Dynamic resistance to short circuits [N] suited to withstand multiple short circuits	Peak short circuit current: 181 kA Cable Clamp spacing: 1,10 m	30.000 N	6.4.4
UV-resistance	high	passed	6.5.1
Flame propagation	1 x 30s, needle flame method	passed	10.1 (IEC 60695-11-5)
	2 x 10s, 50 W test flame method	V-0	UL 94 V (IEC 60695-11-10)
	5 x 5s, 500 W test flame method	5VA	UL 94 5V (IEC 60695-11-20)
	3 min	S3	DIN 5510

Use of Elastic Inlays:

- As a cushion for elastic adjustment of cable diameter changes due to operational load changes and/or changes in the ambient temperature
- Precise cable fixation and absorption of weight forces, primarily on cables installed along inclines or attached to vertical surfaces where restraint of axial movement is essential
- Compensation of vibrations, e.g. in wind turbines, without reducing retention forces
- Expansion of the Clamp's clamping area, for cables with a smaller outer diameter
- Elastic Inlay 100 mm x 100 mm for KR 75/100, KR 100/130
- Elastic Inlay 150 mm x 140 mm for KR 130/160, KR 160/200, KR 200/250



100%
MADE IN
GERMANY

KR SERIES

EXAMPLES OF MOUNTING METHODS

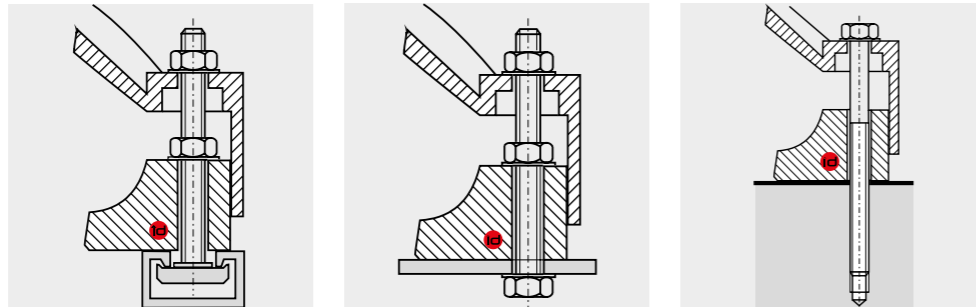

▲ Mounting types

► **Bundling:**

Also suitable for bundled fastening of multiple cables with different cable outer diameters

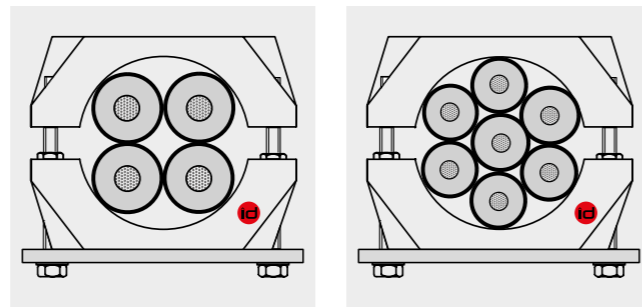

Torque for tightening the fastening material:
Upper part: 8 Nm*
Lower part: 20 Nm

* Contact id-Technik for trailing cables (EPDM, rubber, etc.), please.

1

UNIVERSAL MOUNTING OPTIONS

adaptable to local conditions

EASY TO MOUNT

respecting the tightening torques of the fastening material

3

MAINTENANCE-FREE

more than 40 years of maintenance- and failure-free operation

2

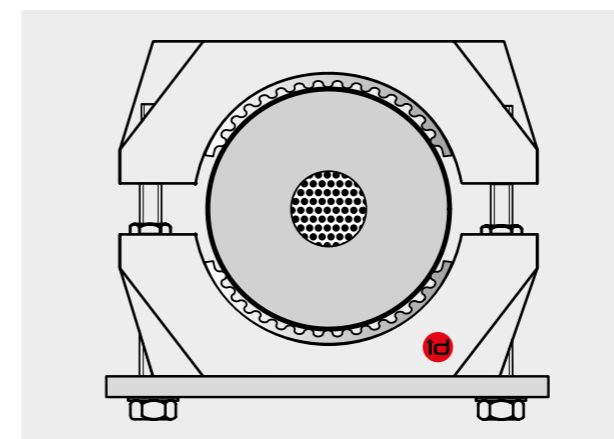

▲ Use with Elastic Inlays

The Elastic Inlays must **ONLY** be inserted into the id-Technik Clamps, not fixed, with the ribs running parallel to the cable lengthways.
To avoid negative impact on the retention, the Elastic Inlays should **NOT** be fixed.
The guarantee expires immediately if any form of adhesive eg. glue, silicone or paste is applied during installation of the clamps on site. Elastic Inlay must retain its full flexibility when used.

KR Series

KR Series



**100%
MADE IN
GERMANY**

KS SERIES

PROPERTIES

Resistance to: Ultraviolet rays, ozone, mineral oils, fuels, salts, alkalis, alcohol, hydrocarbons, ketones, ether, termites and radioactive rays*

Flame resistance: UL94 5VA (IEC 60695-11-20) UL94 V-0 (IEC 60695-11-10) IEC 61914 following IEC 60695-11-5 Classification following DIN 5510, part 2 Flammability class: S3

Thermal expansion: 0.01% per 10°C temperature increase

Tensile strength: 120 N/mm²

Flexural strength: 210 N/mm²

TEMPERATURE RANGE

Ambient temperature: down to -60°C*

Continuous operation: up to 120°C

Permitted short-term heating: up to 220°C

Operation life: more than 40 years of maintenance- and failure-free operation

MATERIAL

High-grade polyamide, fibreglass-reinforced, coloured black, with special UV protection, fully recyclable, self-extinguishing, low-smoke, zero halogen (LSZH), non-toxic, non-corrosive, non-metallic, non-magnetic

Applications:

Fastening of single-core cables in trefoil formation. Unrestricted application indoors and outdoors between -60°C and +120°C.

Outer diameter of cables: 22 mm to 46 mm

Dynamic resistance to short circuits: 13.000 N

Torque for tightening the fastening material: Upper part: 5 Nm** Lower part: 15 Nm

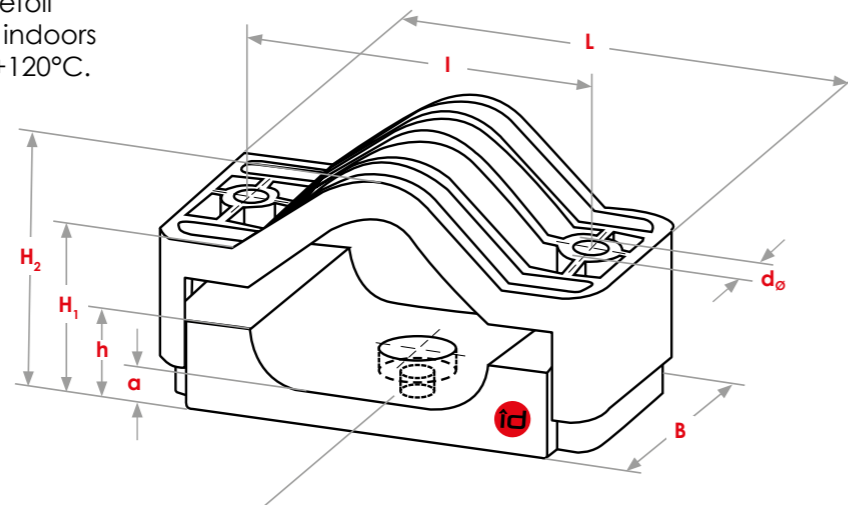

The assembly hole in the bottom part of the KS series allows a direct fastening to lattice, concrete and wooden masts, suitable for M10 rod threaded.

Dimensions in mm

Type	D ₀	D ₀ ++	L	B	I	H ₁	H ₂	h	a	d ₀	Screw thread
KS 25/36	25-36	22-33	150	80	110	55-75	77-97	35	19	12	M10/12
KS 33/46	33-46	30-43	170	80	130	55-85	85-115	35	15	12	M10/12

D₀: Outer cable diameter
D₀++: ~ with two Elastic Inlays

* For more information contact id-Technik, please.
** Contact id-Technik for trailing cables (EPDM, rubber, etc.), please.

Standard IEC 61914 id-Technik Cable Clamps have been type-tested by accredited test institutes to the international standard IEC 61914.



Legal compliance

- Directive 2011/65/EU (RoHS)
- Regulation (EC) No. 1907/2006 (REACH regulation)

Constructional features

- Particularly high dynamic and mechanical strength and heat resistance due to special fibreglass-reinforced polyamide
- Safe restraint of dynamic forces of high short circuit currents, without damage to the cables, also for multiple short circuits
- Type-tested to IEC 61914 – cable cleats for electrical installations - reports from accredited institutes regarding dynamic short circuit currents, the fire-resistance of the material, and mechanical properties of the Cable Clamps are available
- Very low surface pressure on cables due to Cable Clamps' large contact area
- Unrestricted application both indoor and outdoor in extreme climates such as deserts, tropics, high altitudes, arctic climate, coastal salt fogs, flooding and ozone due to special resistance to ageing, ultraviolet rays and ozone
- Easy to mount without special instruments and maintenance-free
- Fastening of Cable Clamps adaptable to all local conditions

Type-Tests to IEC 61914 on Series KS Cable Clamps approved results in highest classification

Classification	Test conditions	Approved results	Paragraph
Material: non-metallic	high-grade polyamide		6.1.2
Operating temperature	-60°C / +120°C	passed	6.2
Resistance to impact	-60°C, 5 kg at 400 mm height	very heavy	6.3.5
Lateral load test [N] – in x-direction – in y-direction	+120°C	11.000 N 19.000 N	6.4.1
Axial load test [N] – without Elastic Inlays – with Elastic Inlays	+120°C	1.000 N 1.250 N	6.4.2
Dynamic resistance to short circuits [N] suited to withstand multiple short circuits	Peak short circuit current: 66,4 kA Cable Clamp spacing: 0,61 m	13.000 N	6.4.4
UV-resistance	high	passed	6.5.1
Flame propagation	1 x 30s, needle flame method	passed	10.1 (IEC 60695-11-5)
	2 x 10s, 50 W test flame method	V-0	UL 94 V (IEC 60695-11-10)
	5 x 5s, 500 W test flame method	5VA	UL 94 5V (IEC 60695-11-20)
	3 min	S3	DIN 5510

Use of Elastic Inlays:

- As a cushion for elastic adjustment of cable diameter changes due to operational load changes and/or changes in the ambient temperature
- Precise cable fixation and absorption of weight forces, primarily on cables installed along inclines or attached to vertical surfaces where restraint of axial movement is essential
- Compensation of vibrations, e.g. in wind turbines, without reducing retention forces
- Expansion of the Clamp's clamping area, for cables with a smaller outer diameter



KS SERIES with factory fixed Elastic Inlays (EE)

100%
MADE IN
GERMANY

PROPERTIES

- Resistance to:** Ultraviolet rays, ozone, mineral oils, fuels, salts, alkalis, alcohol, hydrocarbons, ketones, ether, termites and radioactive rays*
- Flame resistance:** UL94 5VA (IEC 60695-11-20)
UL94 V-0 (IEC 60695-11-10)
IEC 61914 following IEC 60695-11-5
Classification following DIN 5510, part 2 Flammability class: S3
- Thermal expansion:** 0.01% per 10°C temperature increase
- Tensile strength:** 120 N/mm²
- Flexural strength:** 210 N/mm²

TEMPERATURE RANGE

- Ambient temperature:** down to -60°C*
- Continuous operation:** up to 120°C
- Permitted short-term heating:** up to 220°C
- Operation life:** more than 40 years of maintenance- and failure-free operation

MATERIAL

High-grade polyamide, fibreglass-reinforced, coloured black, with special UV protection, fully recyclable, self-extinguishing, low-smoke, zero halogen (LSZH), non-toxic, non-corrosive, non-metallic, non-magnetic

Applications:
Fastening of single- and multi-core cables. Unrestricted application indoors and outdoors between -60°C and +120°C.

Outer diameter of cables:
22 mm to 43 mm

Dynamic resistance to short circuits:
13.000 N

Tightening Torque for fixing material:
Upper part: 5 Nm**
Lower part: 15 Nm

Material Elastic Inlay:
EPDM, one-side ribbed

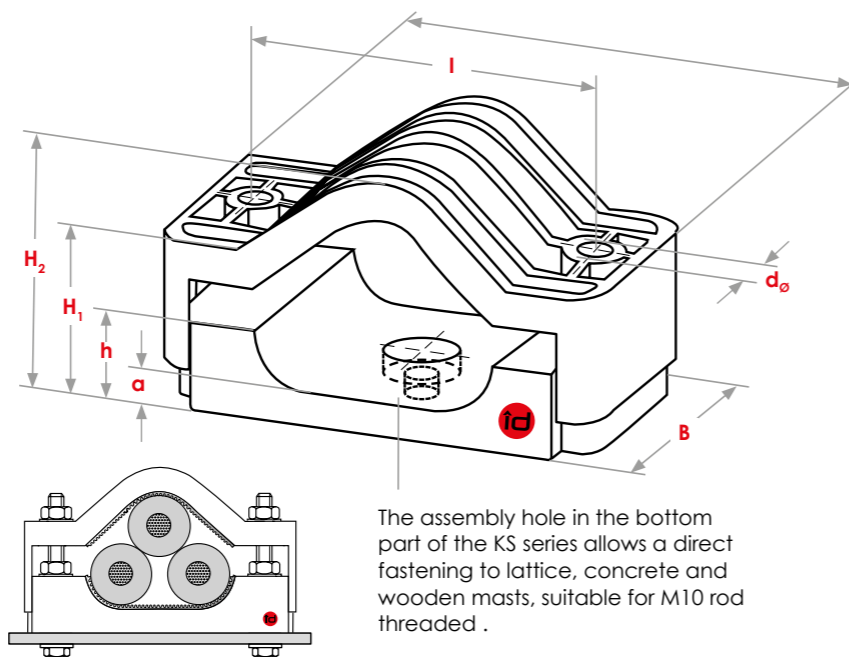

Use with Elastic Inlays, e.g. KS 25/36-2

Dimensions in mm

Type	D ₀ ++	L	B	I	H ₁	H ₂	h	a	d ₀	Screw thread
KS 25/36-2	22-33	150	80	110	55-75	77-97	35	19	12	M10/12
KS 33/46-2	30-43	170	80	130	55-85	85-115	35	15	12	M10/12

D₀++: ~ with two Elastic Inlays

* For more information contact id-Technik, please.
** Contact id-Technik for trailing cables (EPDM, rubber, etc.), please.





100%
MADE IN
GERMANY

KS SERIES

EXAMPLES OF MOUNTING METHODS

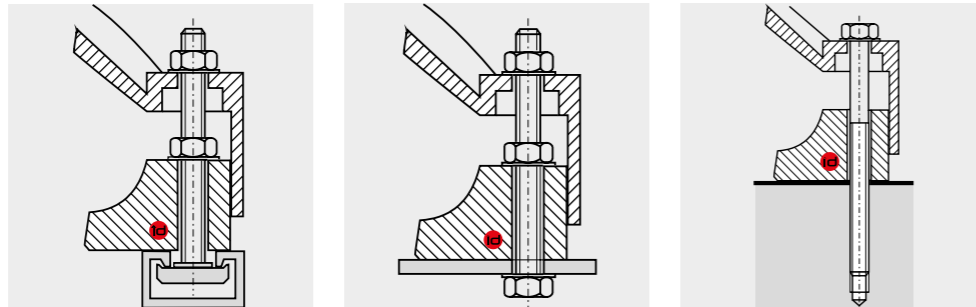

▲ ▼ Mounting types

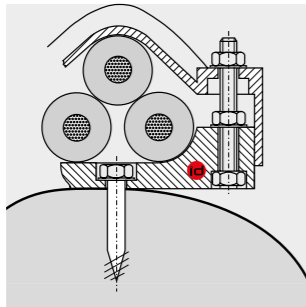

◀ The assembly hole in the bottom part of the KS series allows a direct fastening to lattice, concrete and wooden masts, suitable for M10 threaded rod.

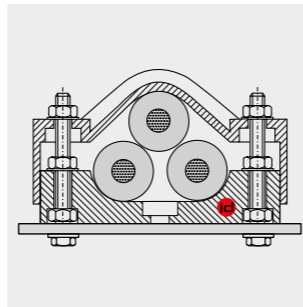

Torque for tightening the fastening material:
Upper part: 5 Nm*
Lower part: 15 Nm

1

UNIVERSAL MOUNTING OPTIONS

adaptable to local conditions

EASY TO MOUNT

respecting the tightening torques of the fastening material

2

3

MAINTENANCE-FREE

more than 40 years of maintenance- and failure-free operation

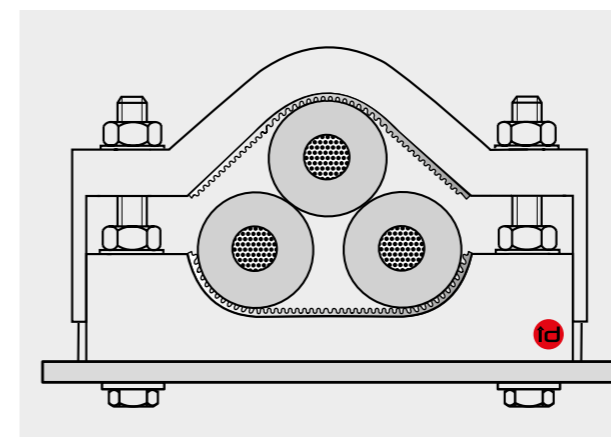
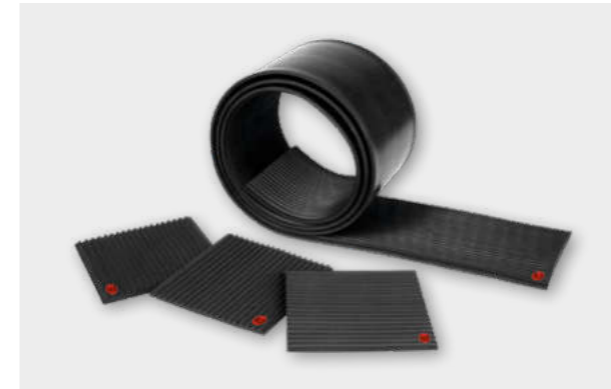

The Elastic Inlays must ONLY be inserted into the id-Technik Clamps, not fixed, with the ribs running parallel to the cable lengthways.

To assist with mounting, Cable Clamps can be supplied with the Elastic Inlays cut to size and fixed in our factory. To avoid negative impact on the retention, the Elastic Inlays should ONLY be fixed by id-Technik.

The guarantee expires immediately if any form of adhesive eg. glue, silicone or paste is applied during installation of the clamps on site. Elastic Inlay must retain its full flexibility when used.

▲ Use with Elastic Inlays, e.g. KS 25/36-2

KS Series

KS Series



**100%
MADE IN
GERMANY**

KP SERIES

PROPERTIES

- Resistance to:** Ultraviolet rays, ozone, mineral oils, fuels, salts, alkalis, alcohol, hydrocarbons, ketones, ether, termites and radioactive rays*
- Flame resistance:** UL94 5VA (IEC 60695-11-20)
UL94 V-0 (IEC 60695-11-10)
IEC 61914 following IEC 60695-11-5
Classification following DIN 5510, part 2 Flammability class: S3
- Thermal expansion:** 0.01% per 10°C temperature increase
- Tensile strength:** 120 N/mm²
- Flexural strength:** 210 N/mm²

TEMPERATURE RANGE

- Ambient temperature:** down to -60°C*
- Continuous operation:** up to 120°C
- Permitted short-term heating:** up to 220°C
- Operation life:** more than 40 years of maintenance- and failure-free operation

MATERIAL

High-grade polyamide, fibreglass-reinforced, coloured black, with special UV protection, fully recyclable, self-extinguishing, low-smoke, zero halogen (LSZH), non-toxic, non-corrosive, non-metallic, non-magnetic

Applications:

Fastening of single-core cables in trefoil formation for high short circuit fores. Unrestricted application indoors and outdoors between -60°C and +120°C.

Outer diameter of cables:
26 mm to 64 mm

Dynamic resistance to short circuits:
25.000 N

Tightening Torque for fixing material:
Upper part: 8 Nm**
Lower part: 15 Nm

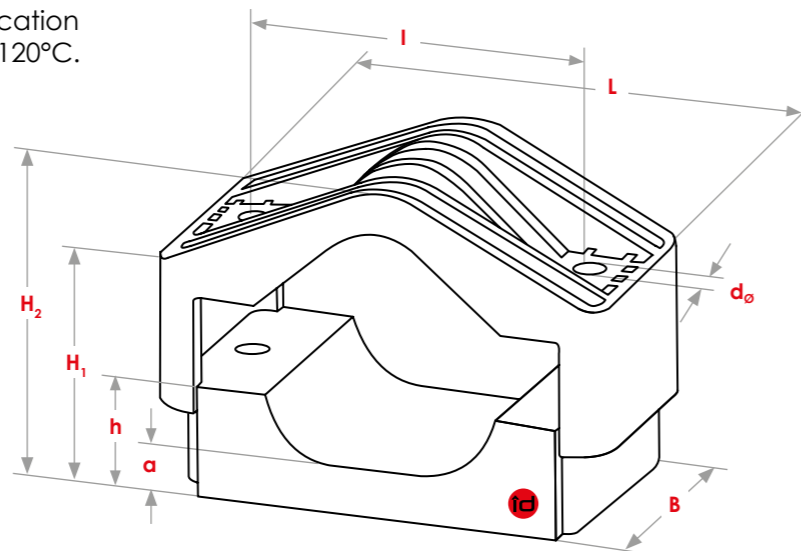

Dimensions in mm

Type	D ₀	D ₀ ++	L	B	I	H ₁	H ₂	h	a	d ₀	Screw thread
KP 29/41	29-41	26-38	172	80	125	60-90	81-111	40	20	14	M12
KP 39/53	39-53	36-50	190	80	145	63-93	101-131	45	20	14	M12
KP 51/64	51-64	48-61	205	90	160	95-123	130-158	70	25	14	M12

D₀: Outer cable diameter
D₀++: ~ with two Elastic Inlays

* For more information contact id-Technik, please.
** Contact id-Technik for trailing cables (EPDM, rubber, etc.), please.

Standard IEC 61914 id-Technik Cable Clamps have been type-tested by accredited test institutes to the international standard IEC 61914.

Legal compliance

- Directive 2011/65/EU (RoHS)
- Regulation (EC) No. 1907/2006 (REACH regulation)

Constructional features

- Particularly high dynamic and mechanical strength and heat resistance due to special fibreglass-reinforced polyamide
- Safe restraint of dynamic forces of high short circuit currents, without damage to the cables, also for multiple short circuits
- Type-tested to IEC 61914 – cable cleats for electrical installations - reports from accredited institutes regarding dynamic short circuit currents, the fire-resistance of the material, and mechanical properties of the Cable Clamps are available
- Very low surface pressure on cables due to Cable Clamps' large contact area
- Unrestricted application both indoor and outdoor in extreme climates such as deserts, tropics, high altitudes, arctic climate, coastal salt fogs, flooding and ozone due to special resistance to ageing, ultraviolet rays and ozone
- Easy to mount without special instruments and maintenance-free
- Fastening of Cable Clamps adaptable to all local conditions

Type-Tests to IEC 61914 on Series KP Cable Clamps approved results in highest classification

Classification	Test conditions	Approved results	Paragraph
Material: non-metallic	high-grade polyamide		6.1.2
Operating temperature	-60°C / +120°C	passed	6.2
Resistance to impact	-60°C, 5 kg at 400 mm height	very heavy	6.3.5
Lateral load test [N] – in x-direction – in y-direction	+120°C	18.000 N 25.000 N	6.4.1
Axial load test [N] – without Elastic Inlays – with Elastic Inlays	+120°C	1.500 N 1.900 N	6.4.2
Dynamic resistance to short circuits [N] suited to withstand multiple short circuits	Peak short circuit current: 66,4 kA Cable Clamp spacing: 0,61 m	25.000 N	6.4.4
UV-resistance	high	passed	6.5.1
Flame propagation	1 x 30s, needle flame method	passed	10.1 (IEC 60695-11-5)
	2 x 10s, 50 W test flame method	V-0	UL 94 V (IEC 60695-11-10)
	5 x 5s, 500 W test flame method	5VA	UL 94 5V (IEC 60695-11-20)
	3 min	S3	DIN 5510

Use of Elastic Inlays:

- As a cushion for elastic adjustment of cable diameter changes due to operational load changes and/or changes in the ambient temperature
- Precise cable fixation and absorption of weight forces, primarily on cables installed along inclines or attached to vertical surfaces where restraint of axial movement is essential
- Compensation of vibrations, e.g. in wind turbines, without reducing retention forces
- Expansion of the Clamp's clamping area, for cables with a smaller outer diameter



KP SERIES with factory fixed Elastic Inlays (EE)

PROPERTIES

- Resistance to:** Ultraviolet rays, ozone, mineral oils, fuels, salts, alkalis, alcohol, hydrocarbons, ketones, ether, termites and radioactive rays*
- Flame resistance:** UL94 5VA (IEC 60695-11-20)
UL94 V-0 (IEC 60695-11-10)
IEC 61914 following IEC 60695-11-5
Classification following DIN 5510, part 2 Flammability class: S3
- Thermal expansion:** 0.01% per 10°C temperature increase
- Tensile strength:** 120 N/mm²
- Flexural strength:** 210 N/mm²

TEMPERATURE RANGE

- Ambient temperature:** down to -60°C*
- Continuous operation:** up to 120°C
- Permitted short-term heating:** up to 220°C
- Operation life:** more than 40 years of maintenance- and failure-free operation

MATERIAL

High-grade polyamide, fibreglass-reinforced, coloured black, with special UV protection, fully recyclable, self-extinguishing, low-smoke, zero halogen (LSZH), non-toxic, non-corrosive, non-metallic, non-magnetic

Applications:
Fastening of single-conductor cables in trefoil formation for high short circuit forces. Unrestricted application indoors and outdoors between -60°C and +120°C.

Outer diameter of cables:
26 mm to 61 mm

Dynamic resistance to short circuits:
25.000 N

Tightening Torque for fixing material:
Upper part: 8 Nm**
Lower part: 15 Nm

Material Elastic Inlay:
EPDM, one-side ribbed

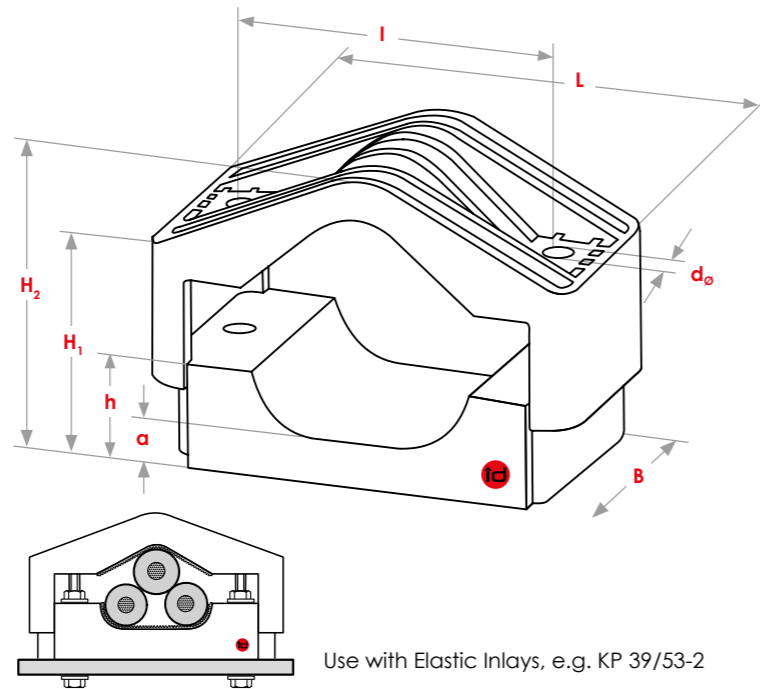

Dimensions in mm

Type	D _o ++	L	B	I	H ₁	H ₂	h	a	d _o	Screw thread
KP 29/41-2	26-38	172	80	125	60-90	81-111	40	20	14	M12
KP 39/53-2	36-50	190	80	145	63-93	101-131	45	20	14	M12
KP 51/64-2	48-61	205	90	160	95-123	130-158	70	25	14	M12

D_o++: ~ with two Elastic Inlays

* For more information contact id-Technik, please.
** Contact id-Technik for trailing cables (EPDM, rubber, etc.), please.



KP Series

KP Series



100%
MADE IN
GERMANY

KP SERIES

EXAMPLES OF MOUNTING METHODS

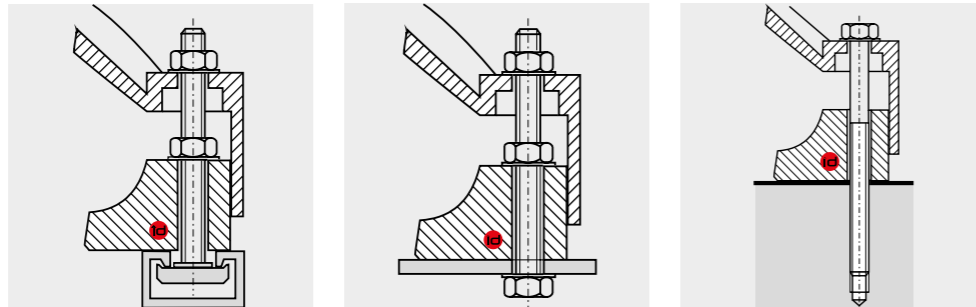

▲ Mounting types



Bundling with fibre-glass reinforced bundling adhesive tapes, functional breakdown of the tapes due to ageing



Replacement with id-Technik Cable Clamps: KP Series

Torque for tightening the fastening material:
Upper part: 8 Nm*
Lower part: 15 Nm

* Contact id-Technik for trailing cables (EPDM, rubber, etc.), please.

1 **UNIVERSAL MOUNTING OPTIONS**
adaptable to local conditions

EASY TO MOUNT
respecting the tightening torques of the fastening material

2

3 **MAINTENANCE-FREE**
more than 40 years of maintenance- and failure-free operation

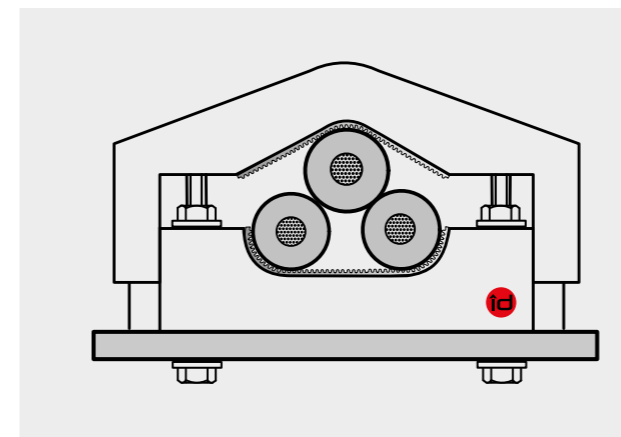
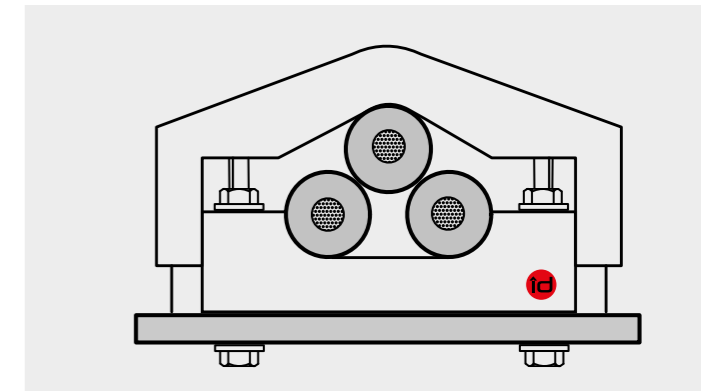
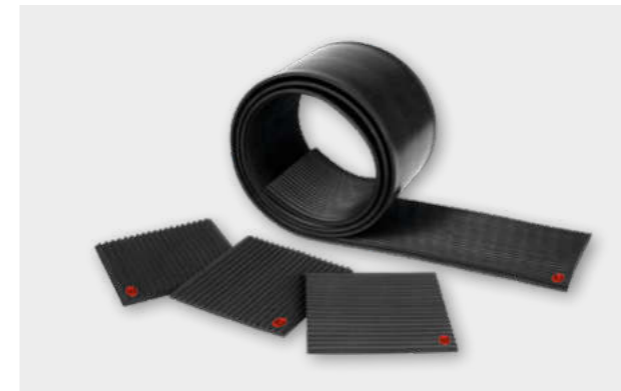

▲ Use with Elastic Inlays, e.g. KP 39/53-2

The Elastic Inlays must ONLY be inserted into the id-Technik Clamps, not fixed, with the ribs running parallel to the cable lengthways.

To assist with mounting, Cable Clamps can be supplied with the Elastic Inlays cut to size and fixed in our factory. To avoid negative impact on the retention, the Elastic Inlays should ONLY be fixed by id-Technik.

The guarantee expires immediately if any form of adhesive eg. glue, silicone or paste is applied during installation of the clamps on site. Elastic Inlay must retain its full flexibility when used.

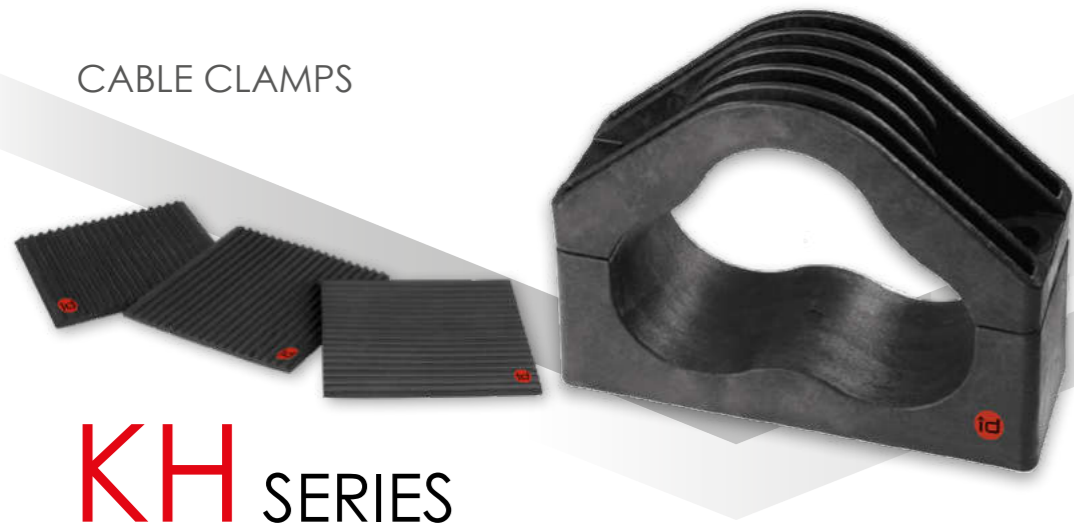

**100%
MADE IN
GERMANY**

KH SERIES

PROPERTIES

- Resistance to:** Ultraviolet rays, ozone, mineral oils, fuels, salts, alkalis, alcohol, hydrocarbons, ketones, ether, fermites and radioactive rays*
- Flame resistance:** UL94 5VA (IEC 60695-11-20) UL94 V-0 (IEC 60695-11-10) IEC 61914 following IEC 60695-11-5 Classification following DIN 5510, part 2 Flammability class: S3
- Thermal expansion:** 0.01% per 10°C temperature increase
- Tensile strength:** 120 N/mm²
- Flexural strength:** 210 N/mm²

TEMPERATURE RANGE

- Ambient temperature:** down to -60°C*
- Continuous operation:** up to 120°C
- Permitted short-term heating:** up to 220°C
- Operation life:** more than 40 years of maintenance- and failure-free operation

MATERIAL

High-grade polyamide, fibreglass-reinforced, coloured black, with special UV protection, fully recyclable, self-extinguishing, low-smoke, zero halogen (LSZH), non-toxic, non-corrosive, non-metallic, non-magnetic

Applications:
Fastening of single-core cables in trefoil formation for high short circuit forces. Unrestricted application indoors and outdoors between -60°C and +120°C.

Outer diameter of cables:
59 mm to 165 mm

Dynamic resistance to short circuits:
30.000 N

Tightening Torque for fixing material:
Upper part: 8 Nm** / Lower part: 15 Nm

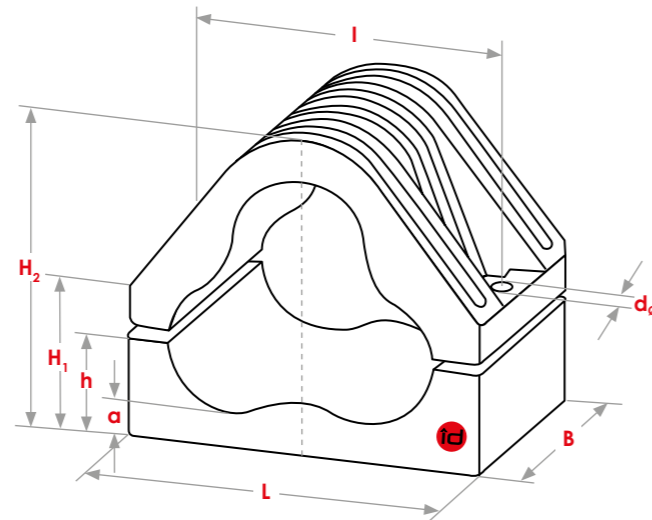

Dimensions in mm

Type	D ₀	D ₀₊₊₊	L	B	I	H ₁	H ₂	h	a	d ₀	Screw thread
KH 62/75	62-75	59-72	230	90	185	114-142	172-200	80	30	18	M16
KH 73/86	73-86	70-83	250	100	210	119-147	192-220	85	30	18	M16
KH 84/97	84-97	81-94	270	100	230	128-156	214-242	95	30	18	M16
KH 95/107	95-107	92-104	290	100	250	136-164	244-262	103	30	18	M16
KH 105/117	105-117	102-114	310	100	270	144-178	248-282	108	30	18	M16
KH 115/140	115-140	112-137	365	120	320	182-242	270-330	145	35	18	M16
KH 138/165	138-165	135-162	505	140	420	215-310	295-390	155	40	20	M18

D₀: Outer cable diameter
D₀₊₊₊ ~ with three Elastic Inlays

* For more information contact id-Technik, please.
** Contact id-Technik for trailing cables (EPDM, rubber, etc.), please.



Standard IEC 61914 id-Technik Cable Clamps have been type-tested by accredited test institutes to the international standard IEC 61914.

Legal compliance

- Directive 2011/65/EU (RoHS)
- Regulation (EC) No. 1907/2006 (REACH regulation)

Constructional features

- Particularly high dynamic and mechanical strength and heat resistance due to special fibreglass-reinforced polyamide
- Safe restraint of dynamic forces of high short circuit currents, without damage to the cables, also for multiple short circuits
- Type-tested to IEC 61914 – cable cleats for electrical installations - reports from accredited institutes regarding dynamic short circuit currents, the fire-resistance of the material, and mechanical properties of the Cable Clamps are available
- Very low surface pressure on cables due to Cable Clamps' large contact area
- Unrestricted application both indoor and outdoor in extreme climates such as deserts, tropics, high altitudes, arctic climate, coastal salt fogs, flooding and ozone due to special resistance to ageing, ultraviolet rays and ozone
- Easy to mount without special instruments and maintenance-free
- Fastening of Cable Clamps adaptable to all local conditions

Type-Tests to IEC 61914 on Series KH Cable Clamps approved results in highest classification

Classification	Test conditions	Approved results	Paragraph
Material: non-metallic	high-grade polyamide		6.1.2
Operating temperature	-60°C / +120°C	passed	6.2
Resistance to impact	-60°C, 5 kg at 400 mm height	very heavy	6.3.5
Lateral load test [N] – in x-direction – in y-direction	+120°C	35.000 N 35.000 N	6.4.1
Axial load test [N] – with three Elastic Inlays	+120°C	1.500 N	6.4.2
Dynamic resistance to short circuits [N] suited to withstand multiple short circuits	Peak short circuit current: 149 kA Cable Clamp spacing: 0,90 m	30.000 N	6.4.4
UV-resistance	high	passed	6.5.1
Flame propagation	1 x 30s, needle flame method	passed	10.1 (IEC 60695-11-5)
	2 x 10s, 50 W test flame method	V-0	UL 94 V (IEC 60695-11-10)
	5 x 5s, 500 W test flame method	5VA	UL 94 5V (IEC 60695-11-20)
	3 min	S3	DIN 5510

Use of Elastic Inlays:

- As a cushion for elastic adjustment of cable diameter changes due to operational load changes and/or changes in the ambient temperature
- Precise cable fixation and absorption of weight forces, primarily on cables installed along inclines or attached to vertical surfaces where restraint of axial movement is essential
- Compensation of vibrations, e.g. in wind turbines, without reducing retention forces
- Expansion of the Clamp's clamping area, for cables with a smaller outer diameter
- Elastic Inlay 100 mm x 100 mm for KH 62/75, KH 73/86, KH 84/97, KH 95/107, KH 105/117
- Elastic Inlay 150 mm x 140 mm for KH 115/140, KH 138/165

KH Series

KH Series



100%
MADE IN
GERMANY

KH SERIES

EXAMPLES OF MOUNTING METHODS

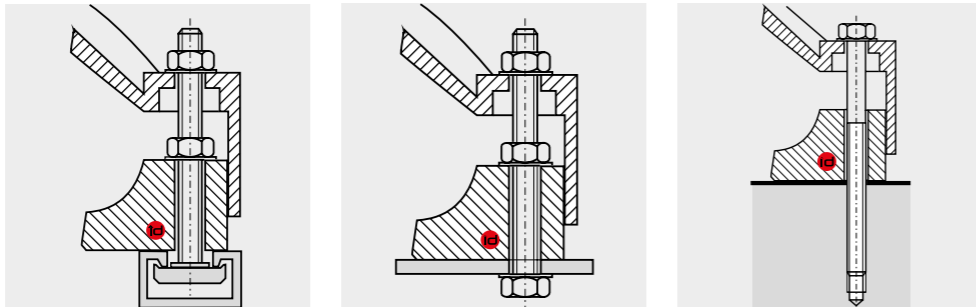

1

UNIVERSAL MOUNTING OPTIONS

adaptable to local conditions

EASY TO MOUNT

respecting the tightening torques of the fastening material

2

3

MAINTENANCE-FREE

more than 40 years of maintenance- and failure-free operation

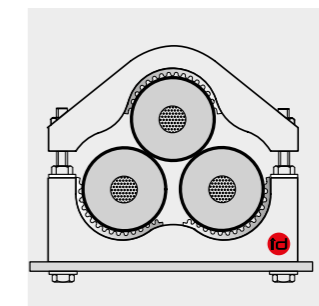

▲ Use with three Elastic Inlays

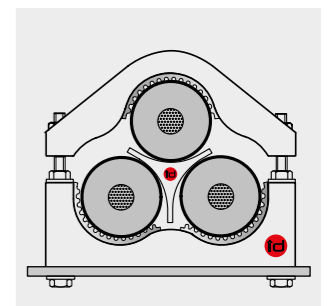

▲ Additional fixation of cables for high- and extra high-voltage in trefoil formation, especially with impregnated paper insulation and at vertical installations. See page 66

The Elastic Inlays must ONLY be inserted into the id-Technik Clamps, not fixed, with the ribs running parallel to the cable lengthways.

To avoid negative impact on the retention, the Elastic Inlays should NOT be fixed.

The guarantee expires immediately if any form of adhesive eg. glue, silicone or paste is applied during installation of the clamps on site. Elastic Inlay must retain its full flexibility when used.

Torque for tightening the fastening material:
Upper part: 8 Nm*
Lower part: 15 Nm

RS3 SERIES



RS4 SERIES



TEMPERATURE RANGE:

Ambient temperature: up to -60°C*

Continuous operation: up to 120°C

MATERIAL: Polyamid

OUTER DIAMETER OF CABLES: 12 mm to 38 mm

DYNAMIC RESISTANCE TO SHORT CIRCUITS: 10.000 N

TIGHTENING TORQUE FOR FIXING MATERIAL:

Upper parts: 8 Nm**

Lower part: 20 Nm

APPLICATIONS

Parallel and/or stacked mounting of single and multi-core cables, unrestricted application outdoors and indoors

TEMPERATURE RANGE:

Ambient temperature: up to -60°C*

Continuous operation: up to 120°C

MATERIAL: Polyamid

OUTER DIAMETER OF CABLES: 12 mm to 38 mm

DYNAMIC RESISTANCE TO SHORT CIRCUITS: 10.000 N

TIGHTENING TORQUE FOR FIXING MATERIAL:

Upper parts: 8 Nm**

Lower part: 20 Nm

APPLICATIONS

Parallel and/or stacked mounting of single and multi-core cables, unrestricted application outdoors and indoors

Mounting example

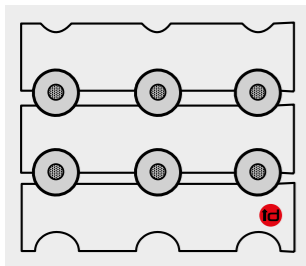

Legal compliance

- Directive 2011/65/EU (RoHS)
- Regulation (EC) No. 1907/2006 (REACH regulation)

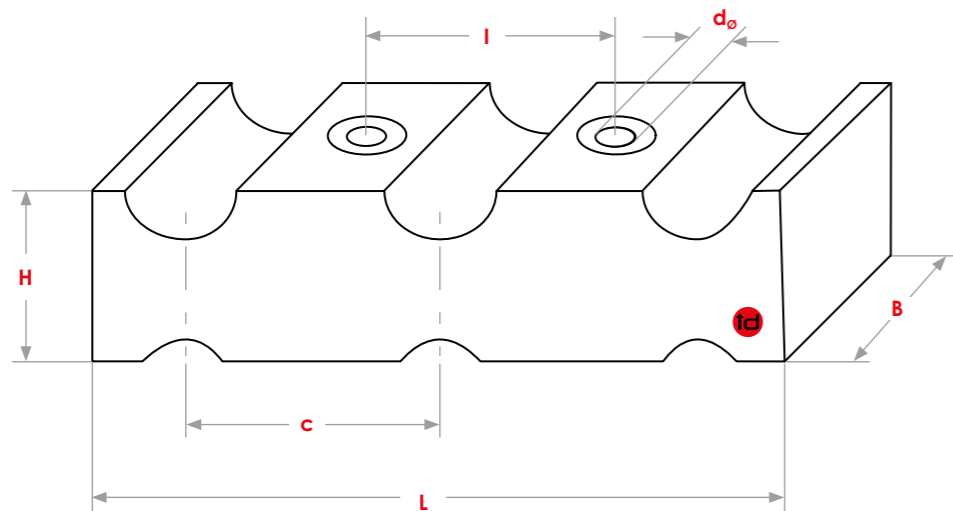

Dimensions in mm

Type	D ₀	L	B	I	H	c	d ₀	Screw thread
RS3 12/38	12-38	202	53	75	51	75	13	M12

D₀: Outer cable diameter

* For more information contact id-Technik, please.
** Contact id-Technik for trailing cables (EPDM, rubber, etc.), please.

Mounting example

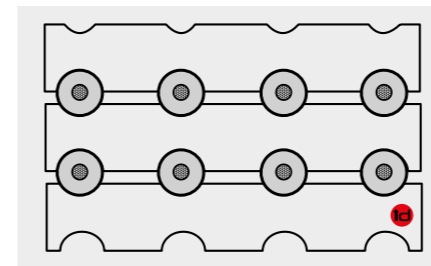

Legal compliance

- Directive 2011/65/EU (RoHS)
- Regulation (EC) No. 1907/2006 (REACH regulation)

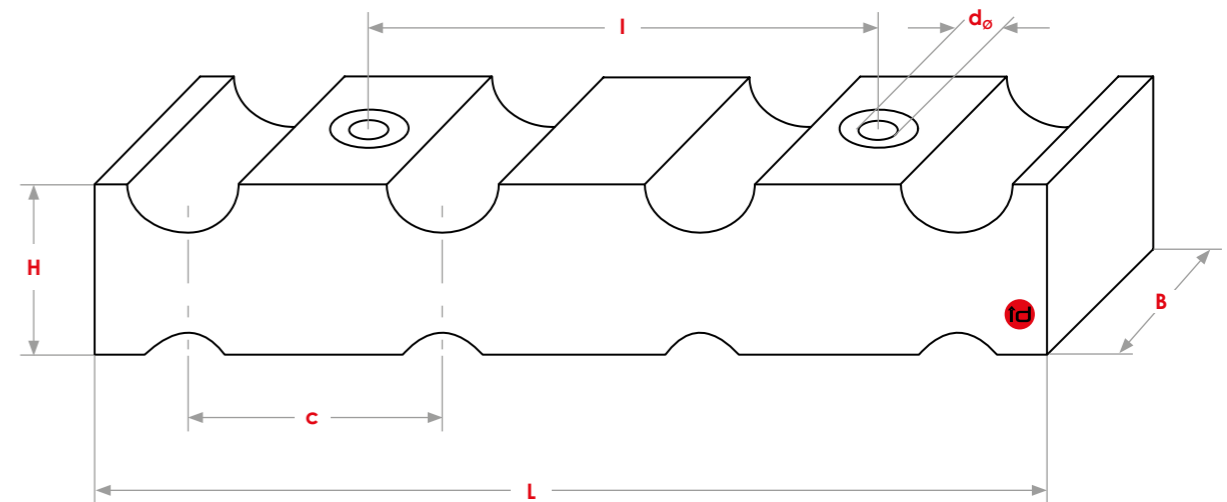

Dimensions in mm

Type	D ₀	L	B	I	H	c	d ₀	Screw thread
RS4 12/38	12-38	275	53	150	51	75	13	M12

D₀: Outer cable diameter

* For more information contact id-Technik, please.
** Contact id-Technik for trailing cables (EPDM, rubber, etc.), please.

RS5 SERIES



TEMPERATURE RANGE:
 Ambient temperature: up to -60°C*
 Continuous operation: up to 120°C

APPLICATIONS
 Parallel and/or stacked mounting of single and multi-core cables, unrestricted application outdoors and indoors

MATERIAL: Polyamid
OUTER DIAMETER OF CABLES: 12 mm to 38 mm
DYNAMIC RESISTANCE TO SHORT CIRCUITS: 10.000 N
TIGHTENING TORQUE FOR FIXING MATERIAL:
 Upper parts: 8 Nm**
 Lower part: 20 Nm

Mounting example

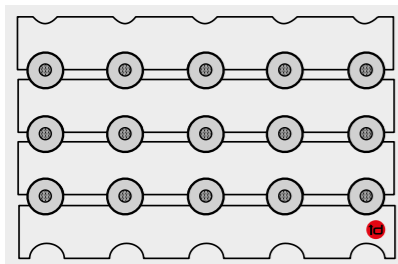

Legal compliance

- Directive 2011/65/EU (RoHS)
- Regulation (EC) No. 1907/2006 (REACH regulation)

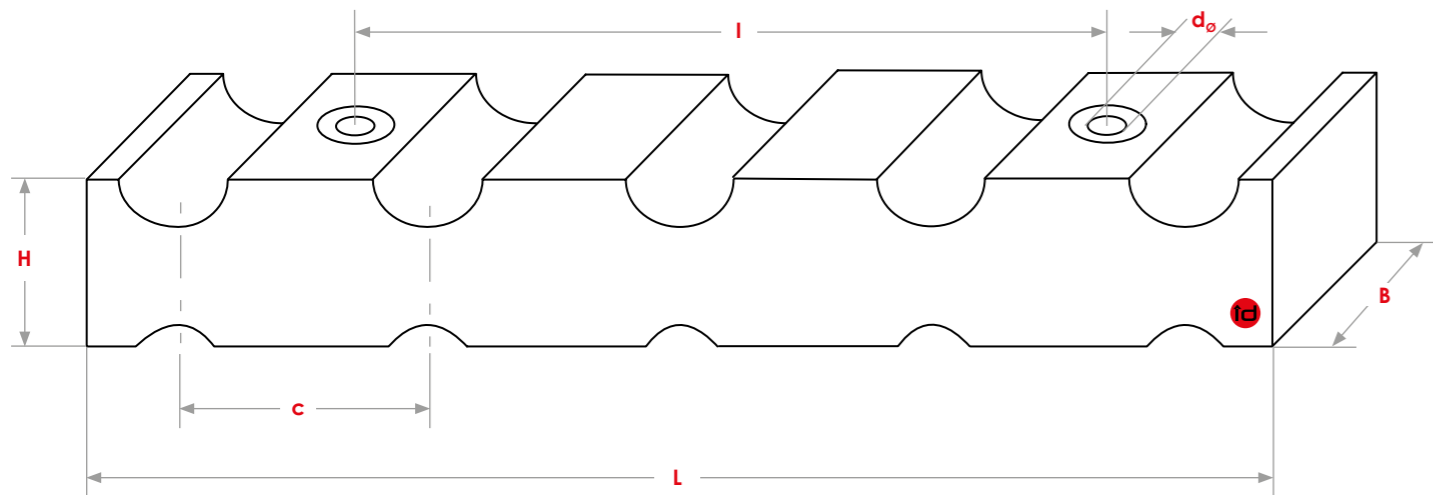

Dimensions in mm

Type	D _o	L	B	I	H	c	d _o	Screw thread
RS5 12/38	12-38	350	53	225	51	75	13	M12

D_o: Outer cable diameter

* For more information contact id-Technik, please.
 ** Contact id-Technik for trailing cables (EPDM, rubber, etc.), please.

MOUNTING EXAMPLES

All Series

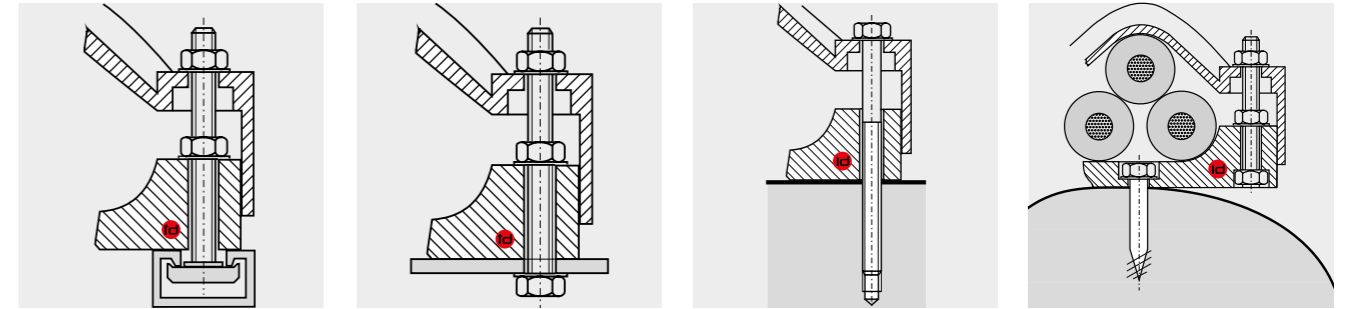

▼ Only KS Serie

All Series with Elastic Inlays

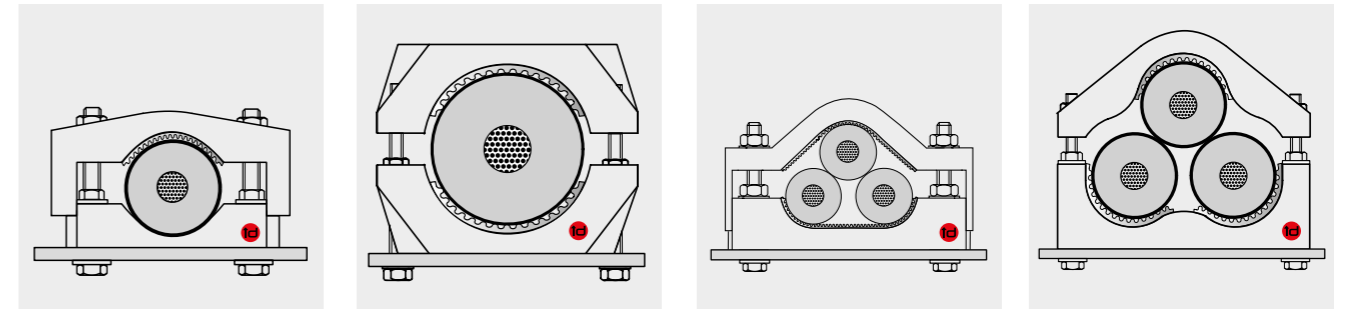

KH Series

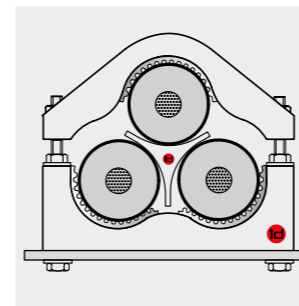

◀ With Elastic Inlays and additional Distance Wedge for cables with impregnated paper insulation

K, KT, KR Series

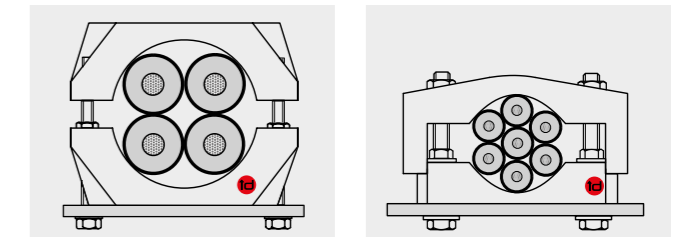

▲ Bundling of multiple cables (including of different diameters)

K-Tower Series

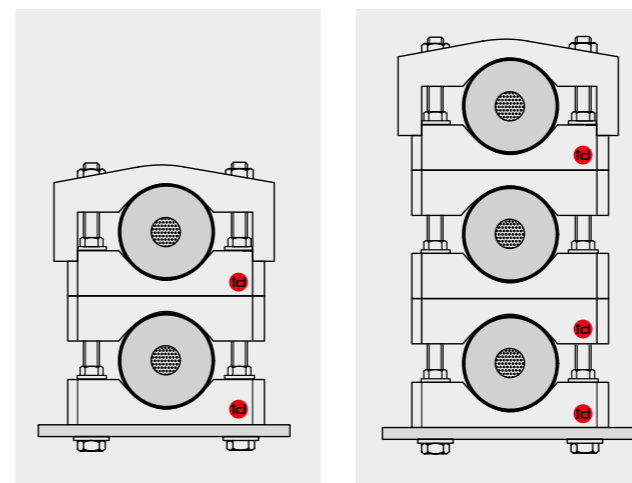

▲ With additional lower parts

RS Series

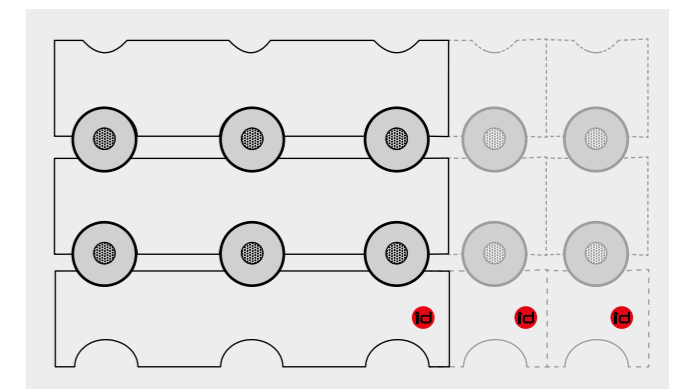



Elastic Inlays (EE)

Application:

- Padding of cables (for outer cable diameters ≥ 60 mm) for elastic compression of diameter variations to avoid damaging of cables caused by changes of load and ambient temperature
- Precise cable fixation and absorption of weight forces, primarily on cables installed along inclines or attached to vertical surfaces where restraint of axial movement is essential
- Compensation of vibrations, e.g. in wind turbines, without reducing retention forces
- Expansion of the Clamp's clamping area, for cables with a smaller outer diameter
- To assist with mounting, Cable Clamps can be supplied with the Elastic Inlays cut to size and fixed in our factory (ONLY K, KT, KS, KP)

Material:

EPDM, one-side ribbed, black

Properties of Elastic Inlays:

- Suitable for outdoor or indoor use on cable installations where ambient temperatures may range from -60°C to $+120^{\circ}\text{C}$
- The Elastic Inlays are highly flexible due to their unilateral convex shaping (groove structure)
- The elasticity of the Inlay absorbs vibrations and moderates vibration transfer to the cables
- Constant inlay-elasticity down to -60°C
- The physical characteristics of Elastic Inlays resist changes despite exposure to changing pressure and temperature conditions; this ensures decades of continuous functionality
- Highly resistant to UV, ozone and salt spray conditions
- Excellent chemical resistance
- Recyclable

Delivery in pieces

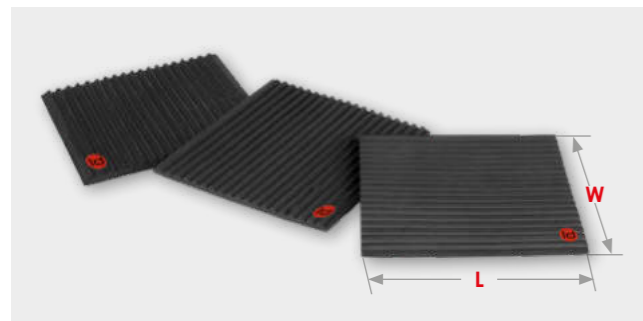

Dimensions: 150 mm (W) x 140 mm (L)
100 mm (W) x 100 mm (L)

Delivery in rolls



Dimensions: 150 mm (W) x 4.2 m (L)
100 mm (W) x 3 m (L)

Elastic Inlay 150 mm x 140 mm for KR 130/160, KR 160/200, KR 200/250, KH 115/140 and KH 138/165
Elastic Inlay 100 mm x 100 mm for all other Cable Clamps

ELASTIC INLAYS MOUNTING EXAMPLES

The Elastic Inlays must ONLY be inserted into the id-Technik Clamps, not fixed, with the ribs running parallel to the cable lengthways. The guarantee expires immediately if any form of adhesive eg. glue, silicone or paste is applied during installation of the clamps on site. Elastic Inlay must retain its full flexibility when used.

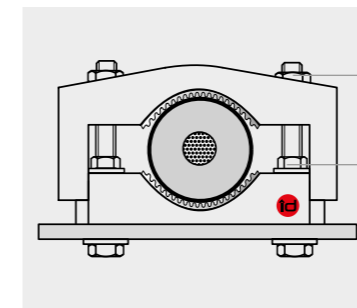

Tightening Torque: 5 Nm

Tightening Torque: 20 Nm

◀ Series K with two Elastic Inlays

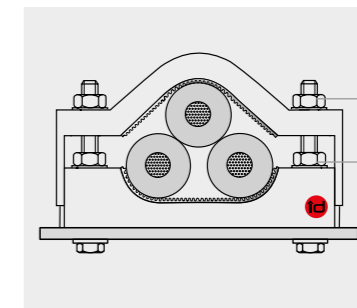

Tightening Torque: 5 Nm*

Tightening Torque: 15 Nm

◀ Series KS with Elastic Inlays

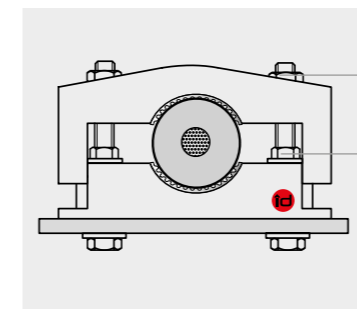

Tightening Torque: 5 Nm

Tightening Torque: 20 Nm

◀ Series KT with two Elastic Inlays

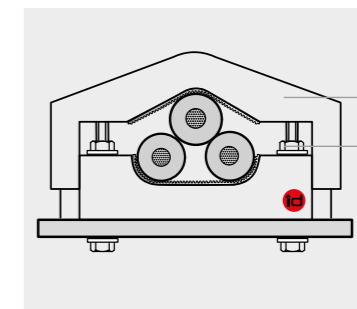

Tightening Torque: 8 Nm

Tightening Torque: 15 Nm

◀ Series KP with Elastic Inlays

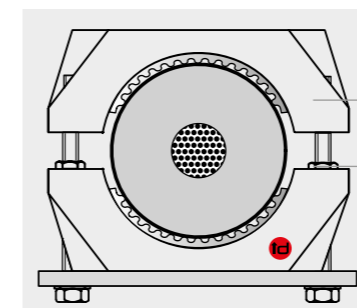

Tightening Torque: 8 Nm

Tightening Torque: 20 Nm

◀ Series KR with two Elastic Inlays

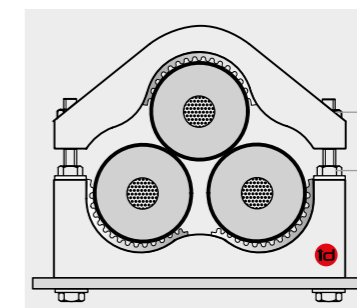

Tightening Torque: 8 Nm

Tightening Torque: 15 Nm

◀ Series KH with three Elastic Inlays

Legal compliance

- Directive 2011/65/EU (RoHS)
- Regulation (EC) No. 1907/2006 (REACH regulation)

* For more information please contact id-Technik.



Distance Wedge for KH-Series

PROPERTIES

- Resistance to:** Ultraviolet rays, ozone, mineral oils, fuels, salts, alkalis, alcohol, hydrocarbons, ketones, ether, termites and radioactive rays*
- Flame resistance:** UL94 5VA (IEC 60695-11-20)
UL94 V-0 (IEC 60695-11-10)
IEC 61914 following IEC 60695-11-5
Classification following DIN 5510, part 2 Flammability class: S3
- Thermal expansion:** 0.01% per 10°C temperature increase
- Tensile strength:** 120 N/mm²
- Flexural strength:** 210 N/mm²

TEMPERATURE RANGE

- Ambient temperature:** down to -60°C*
- Continuous operation:** up to 120°C
- Permitted short-term heating:** up to 220°C
- Operation life:** more than 40 years of maintenance- and failure-free operation

MATERIAL

High-grade polyamide, fibreglass-reinforced, coloured black, with special UV protection, fully recyclable, self-extinguishing, low-smoke, zero halogen (LSZH), non-toxic, non-corrosive, non-metallic, non-magnetic

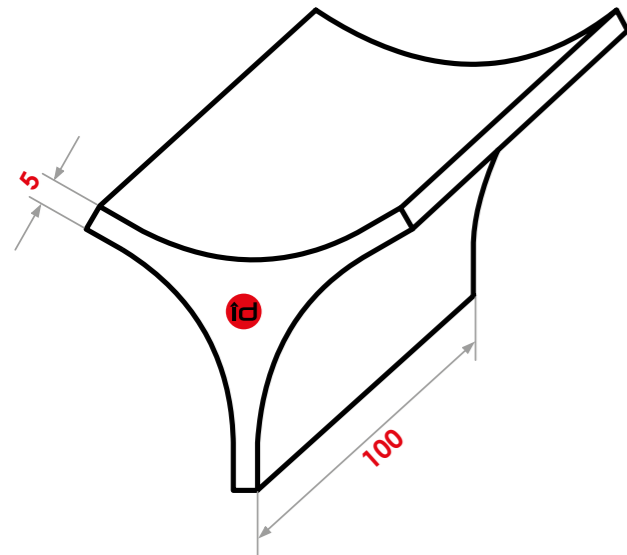

Legal compliance

- Directive 2011/65/EU (RoHS)
- Regulation (EC) No. 1907/2006 (REACH regulation)

Applications:

Fixation for not dimensionally stable cable design like high voltage oilfilled cable or trailing cable (rubber)

Outer diameter of cables:

57 mm to 112 mm

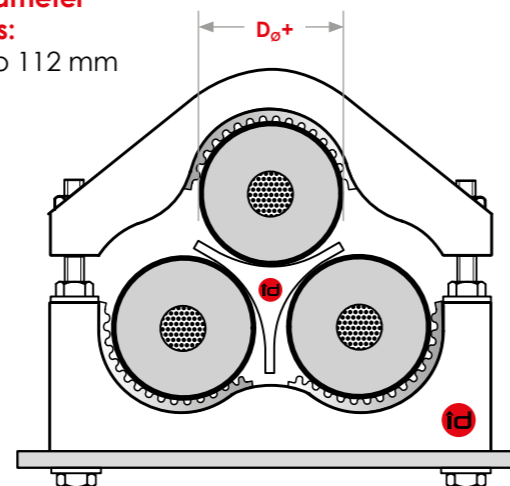

Dimensions in mm

Wedge Type	D _o +	Cable Clamp type
S 57/92	57-70	KH 62/75
	68-81	KH 73/86
	79-92	KH 84/97
S 90/112	90-102	KH 95/107
	100-112	KH 105/117

D_o+: outer cable diameter of the single cables using Distance Wedge and Elastic Inlays

* For more information please contact id-Technik.





Assembly instructions

Dear User,

in the following instructions, step by step descriptions are provided for the installation of the id-Technik Cable Clamps and accessories. It is important that the sequence of the assembly steps is adhered to, without any deviations or changes. Only employ trained staff.

Important: For an appropriate use and to guarantee an optimized installation all components, such as Cable Clamps, Elastic Inlays, cables, trailing cables etc. need to be clean and dust free!

Liability and warranty

The information shown in these assembly instructions describes approved methods for safe and proper handling of id-Technik products. They incorporate the requirements of applicable industry standards and regulations, as well as state-of-the-art cable support and restraint developments and the experience gained by id-Technik through many years of assisting in a wide range of cable system applications.

It should be noted that the illustrations are not drawn to scale. These assembly instructions must be read in their entirety and fully understood before starting any work! The manufacturer assumes no liability for damage and malfunctions resulting from the use of non-approved installation methods.

The manufacturer reserves the right to make technical changes to the instructions.

Intended use

The operational safety of the id-Technik products is guaranteed provided the products are used as intended. In order to ensure optimum performance and avoid hazards, these products must not be modified, extended or changed in any manner without the express approval of the manufacturer. Any use of these products other than in the manner described in these instructions is prohibited and is considered to be improper use.

id-Technik GmbH and/or its authorised representatives are not liable for any claims resulting from improper use of the products. The operator alone is liable for any damage or injury caused by improper use of, or changes to, the products.

Changes to the products

In order to avoid hazards and to ensure optimum performance, the products may not be modified, extended or changed if not expressly approved by the manufacturer.

Assembly instructions for K and KT Series

Selection of fastening material:

Material and corrosion resistance:

The choice of material for the fasteners is dependent on the installation environment and operating conditions (e.g. galvanised, stainless steel, etc.), strength grade 4.8 - 8.8

Fastener diameter:

depends on the Cable Clamp (dimension: screw size)

Fastener Length:

depends on the Cable Clamp dimension and type of substructure

Type of screw:

depends on the substructure (e.g. hexagon screws, T-head screws, rod threaded, etc.); not included in delivery

List of individual components:

Cable Clamp type	Outer diameter of cable	Screw size	Minimum screw length
K 26/38	24-38 mm	M10/12	70 mm + x
K 36/52	36-52 mm	M10/12	79 mm + x
K 50/75	50-75 mm	M10/12	100 mm + x
K 66/90	66-90 mm	M12	112 mm + x
KT 25/39	25-39 mm	M12	83 mm + x

X corresponds to the height of the substructure.

1 Tightening Torque: 20 Nm

Only flat washers may be used. No spring or snap rings!

2

2x [washer] 2x [washer]

3 Tightening Torque: 5 Nm

Alternating, tighten nuts with an appropriate torque wrench. Do not use self-securing/self-locking nuts, this prohibits a defined tightening torque.

It is essential to respect the specified tightening torques, especially for the upper part, to guarantee perfect and reliable functioning of the cable installation for the long-term.

Assembly instructions for K-Tower Series

Selection of fastening material:

Material and corrosion resistance:

The choice of material for the fasteners is dependent on the installation environment and operating conditions (e.g. galvanised, stainless steel, etc.), strength grade 4.8 - 8.8

Type of screw:

depends on the substructure (e.g. hexagon screws, T-head screws, rod threaded, etc.); not included in delivery

Fastener diameter:

depends on the Cable Clamp (dimension: screw size)

Fastener Length:

depends on the number of stacked Cable Clamps, the cable outer diameter and type of substructure

List of individual components Double Tower:

Cable Clamp type	Outer diameter of cable	Screw size	Minimum screw length
K 26/38	24-38 mm	M10	135 mm + x
K 36/52	36-52 mm	M10	165 mm + x
K 50/75	50-75 mm	M10	215 mm + x

X corresponds to the height of the substructure.

List of individual components Triple Tower:

Cable Clamp type	Outer diameter of cable	Screw size	Minimum screw length
K 26/38	24-38 mm	M10	185 mm + x
K 36/52	36-52 mm	M10	235 mm + x
K 50/75	50-75 mm	M10	305 mm + x

X corresponds to the height of the substructure.

Only flat washers may be used. No spring or snap rings!



Alternating, tighten nuts with an appropriate torque wrench. Do not use self-securing/self-locking nuts, this prohibits a defined tightening torque.

It is essential to respect the specified tightening torques, especially for the upper part, to guarantee perfect and reliable functioning of the cable installation for the long-term.



Assembly instructions for KR Series

Selection of fastening material:

Material and corrosion resistance:

The choice of material for the fasteners is dependent on the installation environment and operating conditions (e.g. galvanised, stainless steel, etc.), strength grade 4.8 - 8.8

Type of screw:

depends on the substructure (e.g. hexagon screws, T-head screws, rod threaded, etc.); not included in delivery

Fastener diameter:

depends on the Cable Clamp (dimension: screw size)

Fastener Length:

depends on the cable outer diameter and type of substructure

List of individual components:

Cable Clamp type	Outer diameter of cable	Dimension Elastic Inlays	Outer diameter of cable with Elastic Inlays	Screw size	Minimum screw length
KR 75/100	75-100 mm	100 x 100 mm	70-95 mm	M12	120 mm + x
KR 100/130	100-130 mm	100 x 100 mm	95-125 mm	M12	152 mm + x
KR 130/160	130-160 mm	150 x 140 mm	125-155 mm	M16	175 mm + x
KR 160/200	160-200 mm	150 x 140 mm	155-195 mm	M16	243 mm + x
KR 200/250	200-250 mm	150 x 140 mm	195-245 mm	M16	270 mm + x

X corresponds to the height of the substructure.



Only flat washers may be used. No spring or snap rings!



Alternating, tighten nuts with an appropriate torque wrench. Do not use self-securing/self-locking nuts, this prohibits a defined tightening torque.

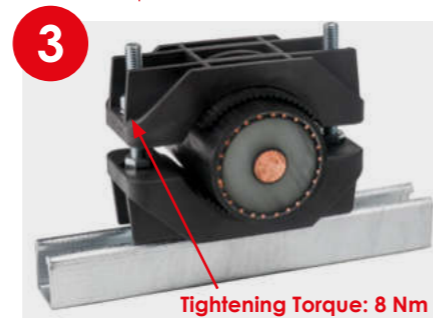

It is essential to respect the specified tightening torques, especially for the upper part, to guarantee perfect and reliable functioning of the cable installation for the long-term.

Assembly instructions for KS Series

Selection of fastening material:

Material and corrosion resistance:

The choice of material for the fasteners is dependent on the installation environment and operating conditions (e.g. galvanised, stainless steel, etc.), strength grade 4.8 - 8.8

Type of screw:

depends on the substructure (e.g. hexagon screws, T-head screws, rod threaded, etc.); not included in delivery

Fastener diameter:

depends on the Cable Clamp (dimension: screw size)

Fastener Length:

depends on the cable outer diameter and type of substructure

List of individual components:

Cable Clamp type	Outer diameter of cable	Screw size	Minimum screw length
KS 25/36	25-36 mm	M10/12	98 mm + x
KS 33/46	33-46 mm	M10/12	108 mm + x

X corresponds to the height of the substructure.



Only flat washers may be used. No spring or snap rings!



Tighten nuts with an appropriate torque wrench alternately only up to the specified tightening torque. Do not use self-securing/self-locking nuts, this prohibits a defined tightening torque.



It is essential to respect the specified tightening torques, especially for the upper part, to guarantee perfect and reliable functioning of the cable installation for the long-term.

Assembly instructions for KP Series

Selection of fastening material:

Material and corrosion resistance:

The choice of material for the fasteners is dependent on the installation environment and operating conditions (e.g. galvanised, stainless steel, etc.), strength grade 4.8 - 8.8

Type of screw:

depends on the substructure (e.g. hexagon screws, T-head screws, rod threaded, etc.); not included in delivery

Fastener diameter:

depends on the Cable Clamp (dimension: screw size)

Fastener Length:

depends on the cable outer diameter and type of substructure

List of individual components:

Clamps for parallel fastening type	Outer diameter of cable	Screw size	Minimum screw length
KP 29/41	29-41 mm	M12	113 mm + x
KP 39/53	39-53 mm	M12	116 mm + x
KP 51/64	51-64 mm	M12	146 mm + x

X corresponds to the height of the substructure.

1 **Tightening Torque: 15 Nm**

2 Only flat washers may be used. No spring or snap rings!

3 **Tightening Torque: 8 Nm**

2x [Nut] 2x [Washer]

Alternating, tighten nuts with an appropriate torque wrench. Do not use self-securing/self-locking nuts, this prohibits a defined tightening torque.

It is essential to respect the specified tightening torques, especially for the upper part, to guarantee perfect and reliable functioning of the cable installation for the long-term.

Assembly instructions for KH Series

Selection of fastening material:

Material and corrosion resistance:

The choice of material for the fasteners is dependent on the installation environment and operating conditions (e.g. galvanised, stainless steel, etc.), strength grade 4.8 - 8.8

Type of screw:

depends on the substructure (e.g. hexagon screws, T-head screws, rod threaded, etc.); not included in delivery

Fastener diameter:

depends on the Cable Clamp (dimension: screw size)

Fastener Length:

depends on the cable outer diameter and type of substructure

List of individual components:

Clamps for parallel fastening type	Outer diameter of cable	Dimension Elastic Inlays	Outer diameter of cable with Elastic Inlays	Screw size	Minimum screw length
KH 62/75	62-75 mm	100 x 100 mm	59-72 mm	M16	170 mm + x
KH 73/86	73-86 mm	100 x 100 mm	70-83 mm	M16	175 mm + x
KH 84/97	84-97 mm	100 x 100 mm	81-94 mm	M16	185 mm + x
KH 95/107	95-107 mm	100 x 100 mm	92-104 mm	M16	197 mm + x
KH 105/117	105-117 mm	100 x 100 mm	102-114 mm	M16	210 mm + x
KH 115/140	115-140 mm	150 x 140 mm	112-137 mm	M16	270 mm + x
KH 138/165	138-165 mm	150 x 140 mm	135-162 mm	M18	340 mm + x

X corresponds to the height of the substructure.

1 **Tightening Torque: 15 Nm**

2

3 **Tightening Torque: 8 Nm**

2x [Nut] 2x [Washer]

Alternating, tighten nuts with an appropriate torque wrench. Do not use self-securing/self-locking nuts, this prohibits a defined tightening torque.

It is essential to respect the specified tightening torques, especially for the upper part, to guarantee perfect and reliable functioning of the cable installation for the long-term.

Assembly instructions for RS3, RS4, RS5 Series

Selection of fastening material:

Material and corrosion resistance:

The choice of material for the fasteners is dependent on the installation environment and operating conditions (e.g. galvanised, stainless steel, etc.), strength grade 4.8 - 8.8

Fastener diameter:

depends on the Cable Clamp (dimension: screw size)

Fastener Length:

depends on the number of stacked RS-Series. Cable Clamp dimension and type of substructure

Type of screw:

depends on the substructure (e.g. hexagon screws, T-head screws, rod threaded, etc.); not included in delivery

List of individual components:

Clamps for parallel fastening type	Outer diameter of cable	Screw size	Minimum screw length
RS3 12/38	12-38 mm	M12	120 mm + x
RS4 12/38	12-38 mm	M12	180 mm + x
RS5 12/38	12-38 mm	M12	240 mm + x

X corresponds to the height of the substructure.

1 Tightening Torque: 20 Nm

▲ 2x [hex nut] 2x [flat washer]

Only flat washers may be used. No spring or snap rings!

2

▼ 2x [hex nut] 2x [flat washer]

3 Tightening Torque: 8 Nm

Alternating, tighten nuts with an appropriate torque wrench. Do not use self-securing/self-locking nuts, this prohibits a defined tightening torque. Tightening Torque for more rows of RS-Series: 8 Nm

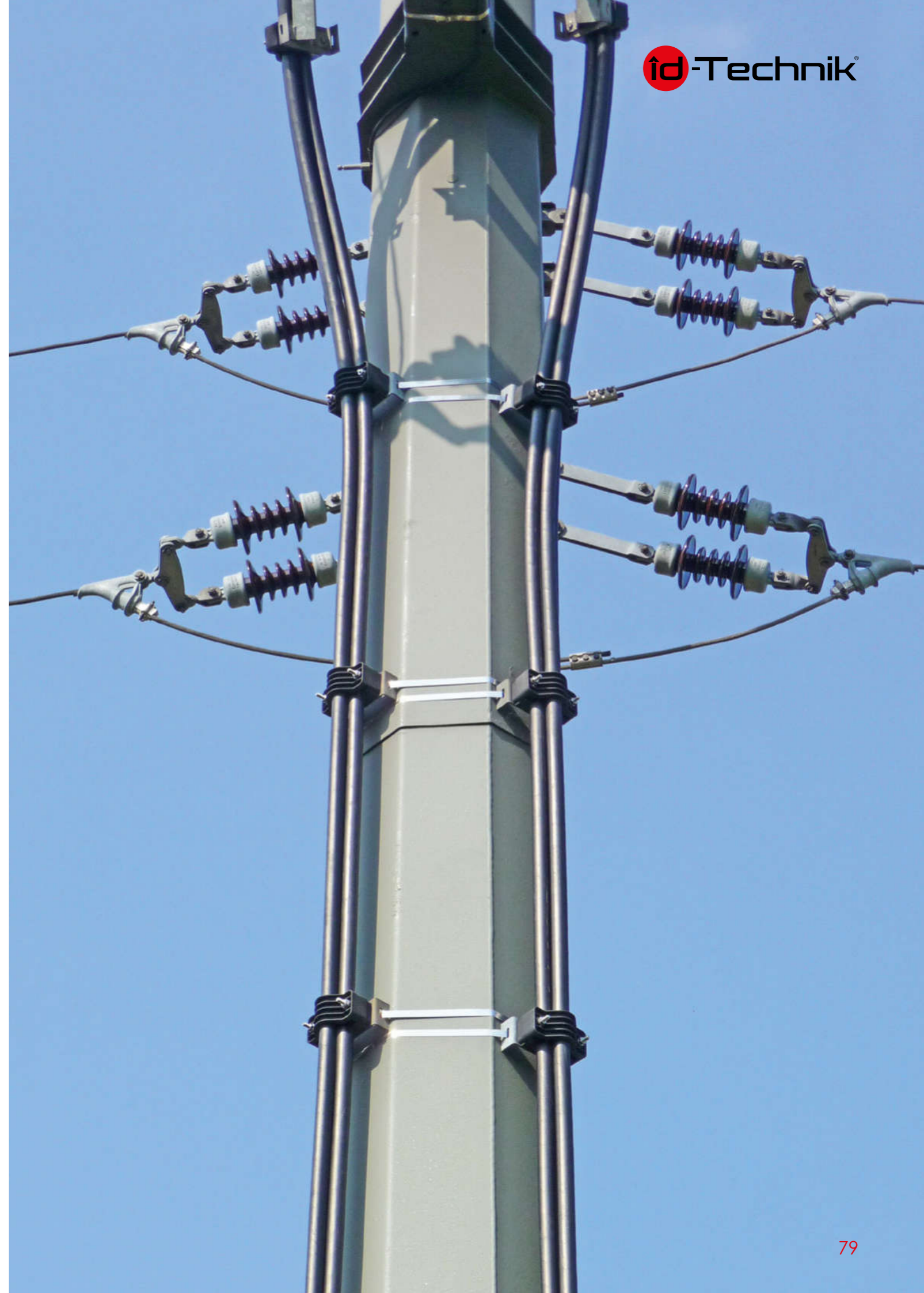

It is essential to respect the specified tightening torques, especially for the upper part, to guarantee perfect and reliable functioning of the cable installation for the long-term.



Explanatory Notes to IEC 61914 – Cable Cleats for Electrical Installations

1. Requirements of the manufacturer

The IEC 61914 requires from the manufacturer of the cable clamps type tests of mechanical and electro-dynamic properties, of UV and corrosion resistance, and flame tests. These type tests must be performed by an accredited testing institute.

Cable clamps certified according to this standard must be designed and manufactured to guarantee a safe handling and safe fastening for wires / cables in accordance with the below classification as given by the manufacturer.

The tests are performed on specific clamps of each series, whereby the clamps are classified according to various characteristics.

2. Classification (Paragraph 6 of the standard)

Material (6.1)

Metallic 6.1.1	Non-metallic 6.1.2	Composite 6.1.3
----------------	--------------------	-----------------

Temperature (6.2)

Minimum temperature	Maximum temperature
---------------------	---------------------

Resistance to impact (6.3)

Very light 6.3.1	Light 6.3.2	Medium 6.3.3	Heavy 6.3.4	Very heavy 6.3.5
------------------	-------------	--------------	-------------	------------------

Type of retention (6.4)

With lateral retention 6.4.1 – in x-direction – in y-direction	With axial retention 6.4.2
--	----------------------------

Resistant to electro-magnetical forces (short circuits):

Withstanding one short circuit 6.4.3	Withstanding more than one short circuit 6.4.4
--------------------------------------	--

Reaction to environmental influences (6.5)

UV-light ¹ 6.5.1 Declared	Not declared	Corrosion / salt spray test ² 6.5.2 Low	High
---	--------------	---	------

Flame propagation (10.1)

Not passed	Passed
------------	--------

Inductive heating (12.2)

Declared ³

¹ only for non-metallic and composite components

² only for metallic and composite components

³ only for ferromagnetic components

3. Marking of the clamps

Furthermore, a marking of the cable clamps and a documentation (7) of the results is required by the IEC 61914.

The marking shall provide following information (7.1):

Manufacturer's or vendor's name / logo / Trademark	Product identification / type
--	-------------------------------

Hereby the marking must be durable and easily legible (7.2).

With the design and manufacturing of cable clamps it has to be ensured that the cable clamps are free of sharp edges, burrs, etc., to avoid damage to the cables and / or conductors and to avoid injury of the assembly staff and operators (8).

4. Required tests for the classification

4.1 Mechanical tests

All mechanical tests are carried out respectively on three samples of the smallest and largest clamp of a series.

Impact test (9.2)

The impact test serves to prove the manufacturer's specified minimum operating temperature and impact strength of the clamp.

Impact tests on non-metallic and composite clamps are carried out after pre-conditioning in an UV-chamber for 700 hours (29 days) at the minimum permanent application temperature as specified by the manufacturer.

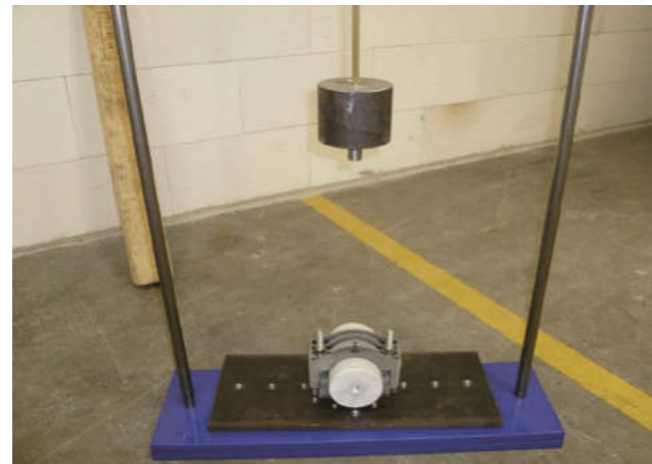

Minimum Temperature [°C]
+5
-5
-15
-25
-40
-60

On metallic clamps, the impact test is carried out at ambient temperature. The impact energy of the hammer is indicated according to the classification in the following table:

Classification	Impact energy [J]	Equivalent mass [kg]	Height [mm]
Very light	0.5	0.25	200
Light	1.0	0.25	400
Medium	2.0	0.5	400
Heavy	5.0	1.7	300
Very heavy	20.0	5.0	400

After testing, the cable clamps must not have any signs of destruction, no breakage or damage must be visible. If in doubt, lateral load tests (9.3) have to be carried out with these cable clamps.

Documentation to be specified by the manufacturer:
 The achieved classification for each series at the minimum permanent application temperature must be documented by the manufacturer in his documentation (if necessary, with an explanation of the torques of the fixing screws).

4.1.2 Lateral load test (9.3)

The lateral load tests serve to demonstrate the manufacturer's specified maximum operating temperature and the maximum lateral restraining forces [N] of the clamps of each series.

These tests must be performed on non-metallic and composite clamps with the maximum permanent application temperature as specified by the manufacturer.

Maximum Temperature [°C]
+ 40
+ 60
+ 85
+ 105
+ 120

On metallic cable clamps the tests are carried out at ambient temperature.

The lateral load test is carried out with test mandrels, representing the smallest possible cable diameter for each clamp. The lateral load test is carried out in two directions:

Experiment testing the lateral load in x-direction

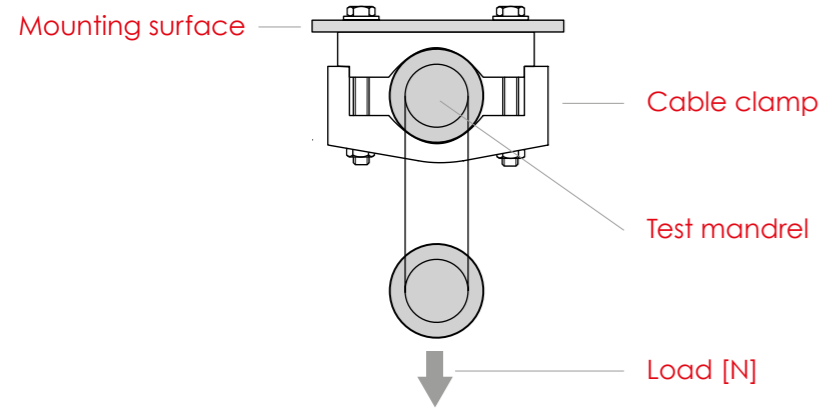

Experiment testing the lateral load in y-direction

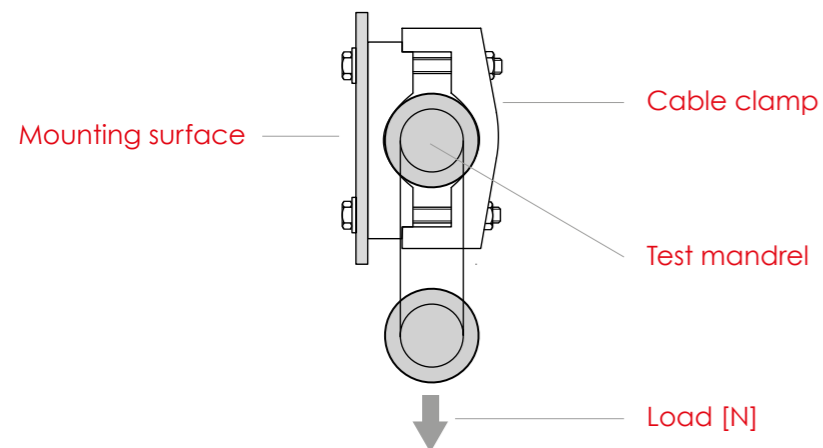

Non-metallic and composite cable clamps must hold the maximum load [N] for 60 minutes.

Metallic clamps must hold the load for 5 minutes.

The maximum movement of the mandrels must be less than 50 % of the mandrel diameter.

The maximum lateral restraining forces [N] for each series at the maximum permanent application temperature are to be documented by the manufacturer in his documents (if necessary, with an explanation of the torques of the mounting screws).

4.1.3 Axial load test (9.4)

The axial load tests serve to demonstrate the manufacturer's specified maximum operating temperature and the maximum axial restraining forces [N] of the clamps of each series.

These tests must be performed on non-metallic and composite clamps with the maximum permanent application temperature as specified by the manufacturer.

Maximum Temperature [°C]
+ 40
+ 60
+ 85
+ 105
+ 120

On metallic cable clamps the tests are carried out at ambient temperature.

The lateral load test is carried out with test mandrels, representing the smallest possible cable diameter for each clamp.

Experiment testing the axial load

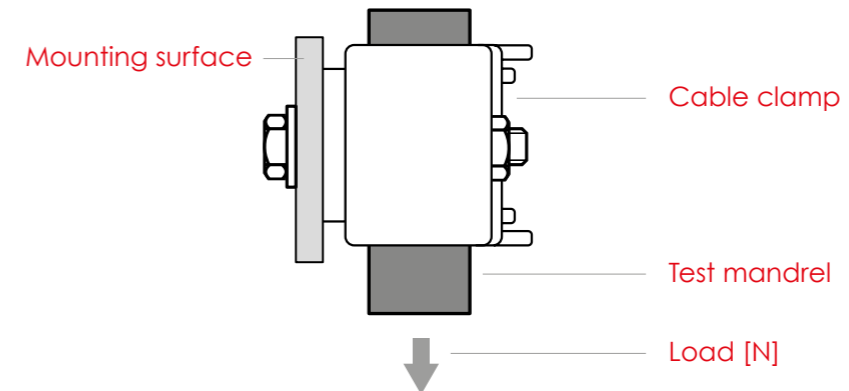

Clamps of all materials must hold the maximum load [N] for 5 minutes.

After the test the axial displacement of the mandrel with respect to the clamp must not exceed 5 mm.

Documentation to be specified by the manufacturer:
The maximum axial restraining forces [N] for each series at the maximum permanent application temperature are to be documented by the manufacturer in his documents (if necessary, with an explanation of the torques of the mounting screws).

4.2 Electrodynamic tests

4.2.1 Test for resistance to electromechanical forces (9.5)

The short circuit tests serve to demonstrate the manufacturer's specified maximum dynamic short circuit resistance of the clamps of each series.

The short circuit tests are carried out on one type of each series.

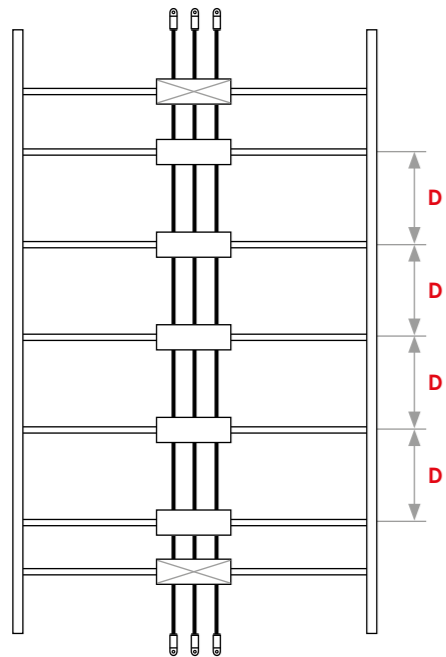

Bundling clamps with security clamps

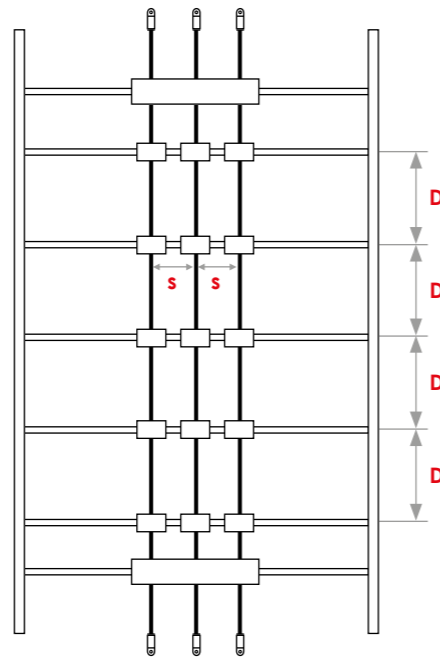

Single clamps with security clamps

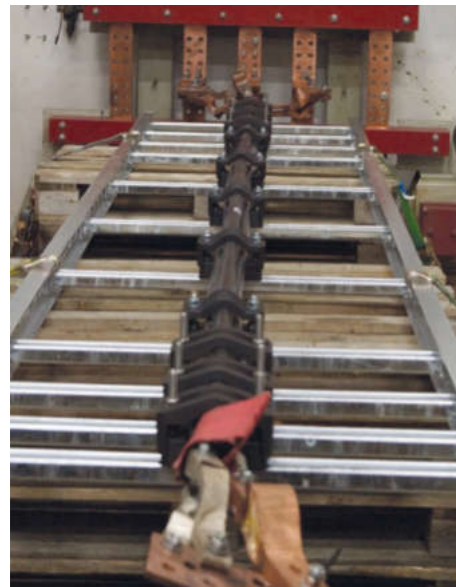

id-Technik Cable Clamps for trefoil formation before the test



id-Technik Cable Clamps for single formation before the test

At a cable section with five clamp positions at equal intervals [D] the following arrangements are distinguished:

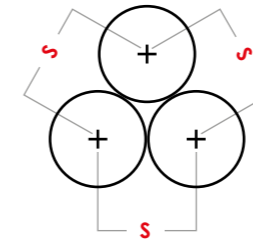

Three cables in trefoil formation with bundling clamp:

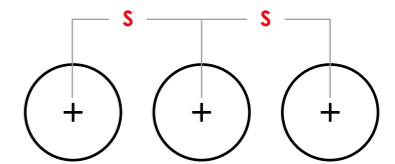

Three cables in parallel arrangement with single clamps:

For each arrangement the test must be carried out with a three-phase short-circuit at the peak short-circuit current [i_p] as specified by the manufacturer.

One end of the cable route is connected to a three-phase power supply and the other end to a three-phase short-circuiting busbar.

The maximum force on the conductor is given by:

$$F = \frac{0.17 * i_p^2}{s}$$

- F = maximum force on the conductor [N/m]
- i_p = peak short-circuit current [kA]
- s = cable centre-line distance [m]

The peak short-circuit current [i_p] as specified by the manufacturer is given by:

$$i_p = \sqrt{\frac{F_s * s}{0.17 * D}}$$

- F_s = maximum dynamic force on the clamp [N]
- D = maximum distance between two neighbouring clamps [m]

Remark:
When determining the distance between two clamps [D], it is essential to ensure that the maximum allowable buckling of the cables according to the cable manufacturer in case of short circuit is not exceeded!

In order to represent realistic values for the user, the manufacturer should perform the short-circuit tests with practical values for the distance between two clamps and short-circuit current.

The classification distinguishes between clamps that withstand one short-circuit (6.4.3) or multiple short-circuits (6.4.4).

Resistant to one short-circuit (6.4.3)

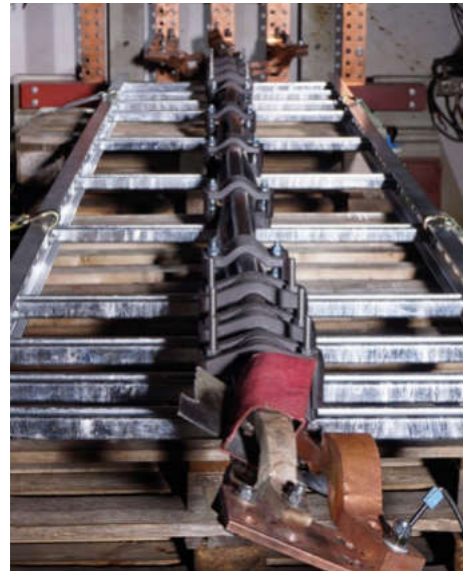

Cable Clamps for trefoil formation after the 1st test



Cable Clamps for single formation after the 1st test

After the short-circuit test:

- there must be no failure that affects the intended function of the cable clamp of keeping the cables in place
- the cable clamps must be intact without damage
- there must be no damage or cuts to the insulation of the cable

Resistant to more than one short-circuit (6.4.4)

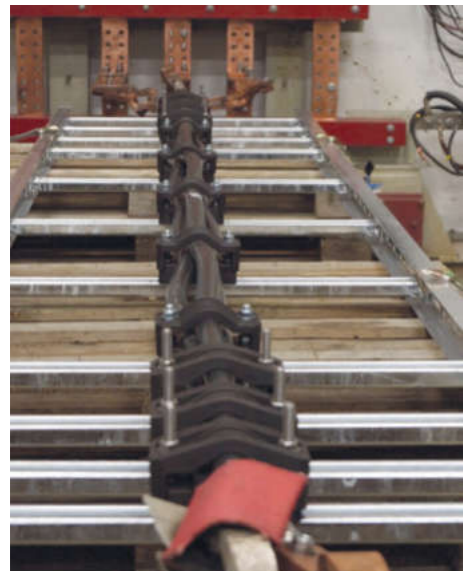

After the first short-circuit, with no damage to the cables or clamps, a second test is performed on the same arrangement with the same peak short-circuit current.

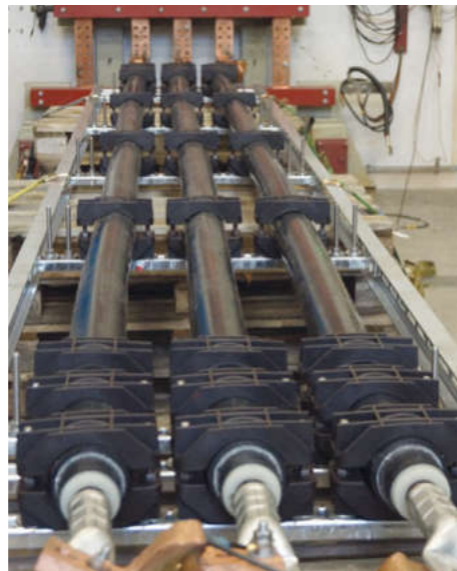

After this test the clamps and cables have to meet the same requirements.

With 1 kV-cables a voltage withstand test is carried out.

Documentation to be specified by the manufacturer (7.3)

- peak short-circuit current i_p [kA]
- symmetrical short-circuit current i''_k [kA]
- outer diameter of the cables used in the test [m]
- cable centre-line distance S [m]
- maximum distance between two clamps D [m]

Remark:

To save the user consuming calculations to determine the carrying capacity of the clamp, the maximum allowable dynamic short circuit strength [N] of the clamps (FS) and the torques of the fixing screws should be specified by the manufacturer.

$$F_s = \frac{0.17 * D * I_p^2}{S}$$

4.3 Flame propagation test (10)

The flame propagation test serves to demonstrate the flame resistance of the material.



Test of flame resistance

The cable clamps are exposed for 30 seconds to a fire test with the needle flame (10.1).

There must be no flame and no embers or no flaming 30 seconds after removal of the needle flame.

Furthermore, the tissue paper may not ignite.

Documentation to be specified by the manufacturer:

The manufacturer must document in his records, whether the cable clamps are resistant to flame or not.

4.4 Test of reaction to environmental influences (11)

4.4.1 Test of resistance to ultraviolet light (11.1)

The UV-test serves to demonstrate the UV-resistance of the material.

The smallest and largest cable clamps of each series are irradiated for 700 hours (29 days) under the conditions described in IEC § 11.1 with UV light.

After UV exposure, the cable clamps must not show any signs of destruction, breakage or damage.

Subsequently, the clamps must pass the impact test (9.2) at the minimum permanent application temperature as specified by the manufacturer.

**Documentation to be specified by the manufacturer:
The manufacturer must document in his records, whether the cable clamps are UV-resistant or not.**

4.4.2 Test of resistance to corrosion (11.2)

The test of resistance to corrosion serves to demonstrate the resistance to corrosion of the material.

Metallic and composite cable clamps must have adequate resistance to corrosion and salt spray. The respective tests are described in the standard at 11.1 and 11.2.

For non-metallic cable clamps these tests are not necessary.

**Documentation to be specified by the manufacturer:
The manufacturer must document in his records, whether the cable clamps are resistant to corrosion or not.**

4.5 Test of inductive heating (12.2)

With the use of ferromagnetic materials, there is the danger of inductive heating of the cable due to eddy currents.

**Documentation to be specified by the manufacturer:
The manufacturer shall apply an appropriate warning.**

Technical changes and errors reserved.

The information presented in these manuals is intended for the guidance of authorized users of the îd-Technik products. Copyright law and intellectual property rights protect all of the content of the îd-Technik manuals and catalogues, including all text, drawings, pictures and other product representations. Reproduction, communication, or other use of this proprietary information is not permitted without prior written consent from îd-Technik GmbH.

îd-Technik GmbH
Hohe Strasse 34-36
68526 Ladenburg
Germany

Tel.: +49 (0) 6203 107 95 88
Fax: +49 (0) 6203 107 95 52

info@id-technik.com
www.id-technik.com