

Operating Instructions

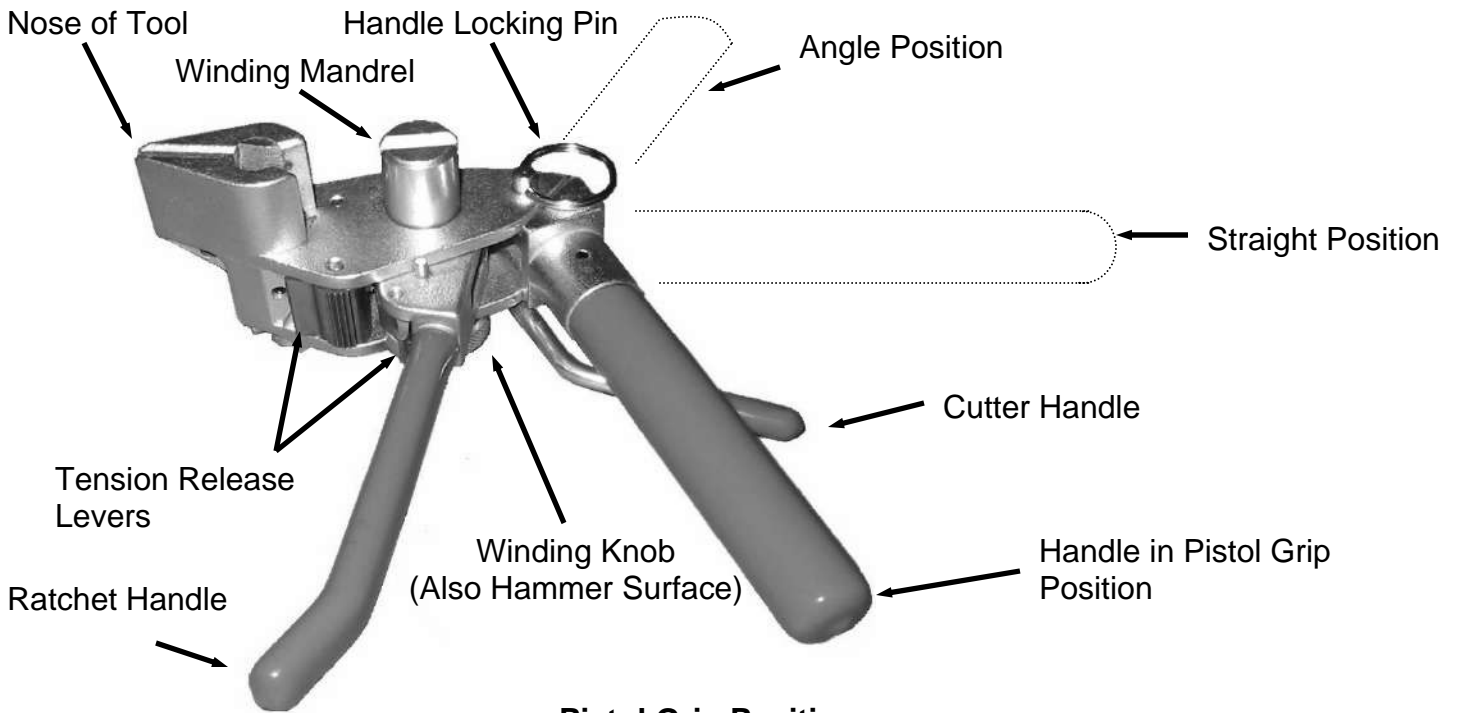

C07569 Bantam Hand Tool



Pistol Grip Position:



1. With the Bantam Tool in the Pistol Grip Position, place the band in the tool with sufficient band in the winding mandrel.



2. With ratcheting action, tension the band until clamp is tight. If necessary, band may be repositioned by releasing tension with levers.



3. Roll tool over as far as tool will go, and push forward cutter handle. Remove tool and tap down ears of clip to complete clamp. Remove excess material from winding mandrel.

Straight or Angle Position:



1. With the Bantam Tool in the Straight Position, place the band in the tool with sufficient band in the winding mandrel.



2. With ratcheting action, tension the band until clamp is tight.



3. Roll tool over as far as tool will go, and push forward cutter handle. Remove tool and tap down ears of clip to complete clamp.

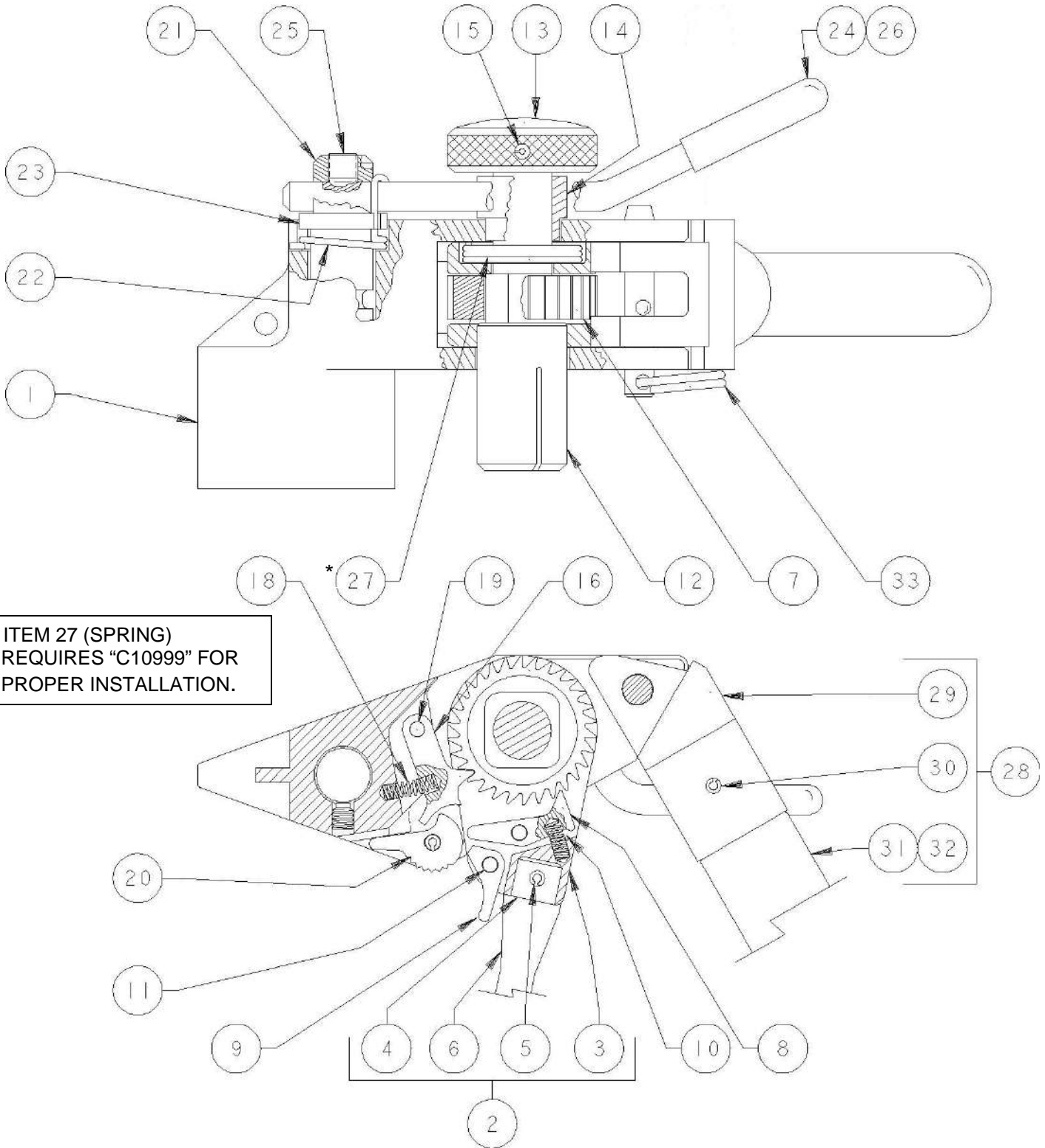

* ITEM 27 (SPRING)
REQUIRES "C10999"
FOR PROPER INSTALLATION.

Repair Parts



C07569 Bantam Hand Tool

* NOTE: ITEM 27 (SPRING) REQUIRES RATCHET SPRING TOOL FOR PROPER INSTALLATION. ORDER PART NUMBER C10999 FOR RATCHET SPRING TOOL AND C09099 FOR SPRING KIT (INCLUDES THREE SPRINGS).

33	C10787	1	PIN, HANDLE, LOCKING
32	C09887	1	...GRIP, HANDLE
31	C08187	1	...HANDLE
30	C09787	1	...PIN, SPRING, 1/8 DIA X 7/8 LONG
29	C08287	1	...ADAPTER, HANDLE
28	C11087	1	HANDLE/ ADAPTER ASSEMBLY, COMBINATION
27	C09087 *	1	SPRING, RATCHET
26	C10087	1	CAP, CUTTER HANDLE
25	C72388	1	SCREW, SET, 1/4-28 X 3/16 LONG
24	C08887	1	HANDLE, CUTTER, STRAP, FINISHED
23	C09187	1	COVER, CUTTER SPRING, FINISHED
22	C09287	1	SPRING, CUTTER
21	C08787	1	BLADE, CUTTER, FINISHED
20	C07187	1	CAM, HOLDING PAWL
19	C09487	2	PIN, GROOVED, 1/8 DIA X 1 LONG
18	C09587	2	SPRING, HOLDING PAWL
17	-----	-	-----
16	C07387	2	PAWL, HOLDING, RIGHT
15	C11287	2	PIN, SPRING, 1/8 DIA X 1.25 LONG
14	C08387	1	SPACER, FINISHED
13	C08487	1	KNOB, WINDING, FINISHED
12	C08687	1	MANDREL, WINDING, FINISHED
11	C09387	1	PIN, GROOVED, 1/8 DIA X .75 LONG
10	C09687	1	SPRING, TENSION PAWL
9	C07687	1	CAM, TENSION PAWL
8	C07487	1	PAWL, TENSION
7	C07887	1	WHEEL, RATCHET
6	C09987	1	...GRIP, RATCHET
5	J02887	1	...PIN, SPRING, 1/8 DIA X 3/4 LONG
4	C07987	1	...HANDLE, RATCHET, COMBINATION
3	C07787	1	...HOUSING, RATCHET
2	C10887	1	HANDLE/HOUSING ASSEMBLY, COMBINATION
1	C06987	1	BODY, FINISHED
ITEM	PART NUMBER	QTY.	DESCRIPTION

Refer to website for warranty information: <http://www.band-it-idex.com/pages/warranty.html>