

wöhner

# 185 POWER

**WELCOME TO THE  
ULTIMATE SYSTEM WORLD**



# 185 POWER

**FLEXIBLE SWITCHING  
WITHIN ONE SYSTEM**

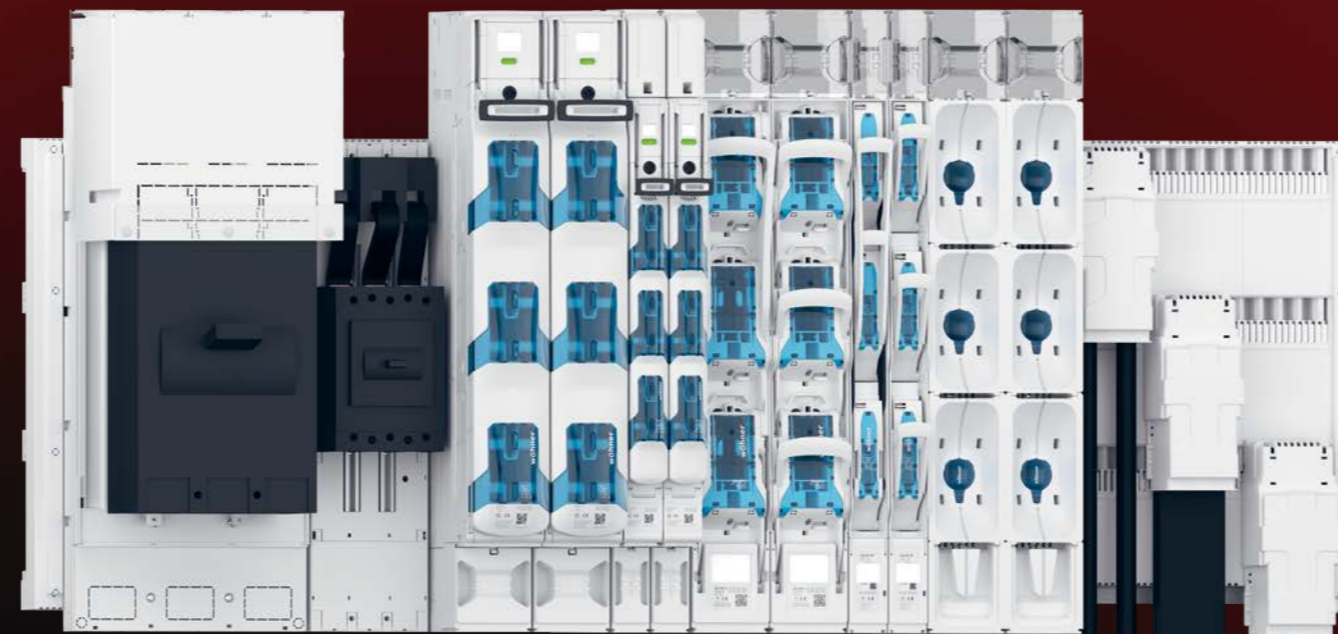

**The 185 mm system solution continues to grow.** QUADRON®185Power Speed, the NH in-line switch-disconnector-fuse

Discover a perfectly matched system with powerful components and maximum ease of mounting thanks to CrossLink®Technology. 185Power from Wöhner offers you a QUADRON® product family highlight in the QUADRON®185Power Speed, the NH in-line switch-disconnector-fuse that can be mounted vertically to a 185 mm busbar system. This is the first time a combination of fast switching NH in-line switch-disconnector-fuse can be included in a mixed installation with other components within a 185 mm system. The system also includes the CRITO®185Power connection strips and connection modules, guaranteeing a compact and flexible connection.

The 185Power system offers you, in addition to a comprehensive NH in-line product family, all the elements required for a sustainable system: from busbar supports, infeed components, and system covers for optimal touch-safe protection, right through to adapters for all standard circuit breakers.

## **BUSBAR SUPPORT AND CrossLink® COVERING SYSTEM**

- + Drill-free mounting of all components through the touch-safe CrossLink® covering system
- + CrossLink® covering system ensures phase segregation
- + Mounting and removal possible on live busbar system

FROM PAGE 8

## **CONNECTION COMPONENTS AND CIRCUIT BREAKER ADAPTER**

- + Adapter to fit all standard circuit breakers
- + Adapter for direct connection to the busbar
- + Connection rail for round conductor, flat conductor and cable lugs
- + Connection module for round conductor, flat conductor and cable lugs

FROM PAGE 12

## **QUADRON®185Power Speed, NH IN-LINE SWITCH- DISCONNECTOR-FUSE**

- + NH in-line switch-disconnector-fuse
- + Operator-independent switching with snap-action switch mechanism
- + Mixed possibilities – multiple possibilities in one system

FROM PAGE 16

## **QUADRON®185Power NH IN-LINE FUSE-SWITCH- DISCONNECTOR**

- + NH in-line fuse-switch-disconnectors size 00 to 3, for 160 A to 630 A, 910 A, 1250 A
- + Rapid, safe mounting of the components to the busbar system
- + Innovative heat dissipation and optimised venting of switching gases

FROM PAGE 20



# ONE SYSTEM ALL THE BENEFITS



Just a revolutionary idea at the start –  
Developing the first 185 mm system solution.

# 185 POWER

## MODULARITY

All components and products are modular and perfectly matched. For the first time you can combine NH in-line switch-disconnector-fuse vertically in a mixed installation with other components within a 185 mm system.



## SIMPLICITY

Innovative CrossLink® connection makes for easy, no-drill mounting. Clamp connection permits all system components to be mounted and contacted effortlessly.



## COMPATIBILITY

Thanks to the EQUES®185Power adapters all standard circuit breaker types can be quickly and easily mounted.



## SAFETY

With the 185Power system, safety is paramount. The comprehensive touch-safe protection for the busbar system and all components guarantees this. In addition the QUADRON® 185Power Speed, the NH in-line switch-disconnector-fuse, whose snap-action switch mechanism is operator-independent and switches securely, represent a new safety dimension in the 185Power system.



## EFFICIENCY

Perfectly matched components from a single source enable a substantial increase in efficiency. The result is a considerable saving of time in engineering, planning, purchasing and system assembly.



## MEASURING

In the 185Power system there are a number of possibilities to quickly and easily integrate current transformers. Retrofitting is possible without requiring additional space.



## STRUCTURE

Standardized system components ensure order and a clean presentation of everything in the control cabinet.





# FURTHER SYSTEM DEVELOPMENT

Innovation has been at the heart of Wöhner's history.

In the early 1980s Wöhner presented its innovative 60 mm busbar system technology. The technology became the industry standard in Europe and is gaining broad acceptance in diverse markets around the globe. Innovation and improved design in pursuit of electrical safety and efficiency have been the hallmark of the Wöhner 60 mm busbar system. The introduction of the 185Power system in 2014 will continue the success in a new dimension. Our horizon has been dramatically broadened.

With the introduction of the QUADRON®185Power Speed, the NH in-line switch-disconnector-fuses, development goes even further.



<p><b>1980</b> 60Classic busbar system</p>	<p><b>1989</b> Double-T profiles extend the 60 mm system to 1600 A</p>	<p><b>1998</b> QUADRON® NH fuse-switch- disconnecter series</p>	<p><b>2000</b> SECUR® in-line fuse-switch- disconnecter series</p>	<p><b>2001</b> SECUR® D0 switch-disconnector</p>	<p><b>2002</b> EQUES® adapter series</p>	<p><b>2006</b> AMBUS® fuse-holders</p>	<p><b>2008</b> CrossLink® Technology</p>	<p><b>2009</b> 30Compact busbar system</p>	<p><b>2012</b> MOTUS® hybrid motor starter</p>	<p><b>2013</b> SECUR® D0 switch-disconnector with SnapLock wire connection technology</p>	<p><b>2014</b> 185Power busbar system</p>	<p><b>2016</b> CrossBoard® basic system QUADRON®185Power Speed, NH in-line switch- disconnecter-fuse</p>	<p><b>2017</b> BROOME10®CrossBoard EQUES®CrossBoard</p>	<p><b>2018</b> CRITO®CrossBoard QUADRON®</p>
--	--	---	--	--	--	--	--	--	--	---	---	--	---	--

# THIS SYSTEM IS ABOUT ELECTRICAL SAFETY

## An all-round care-free package

The innovative CrossLink®Technology from Wöhner meets the requirements placed on power distribution equipment with readily available modular components delivering high levels of system dependability and personal safety. Systems can be engineered in the most straight forward way and modified to evolving application requirements. In the 185Power system the CrossLink®185Power covering modules, base plate profile, and the busbar support covers ensure comprehensive touch-safe busbar system protection. Integral system partitioning saves time when mounting and provides optimum safety thanks to the matched components. CrossLink®Technology advantages continue in the touch protection of longitudinal busbar connectors.

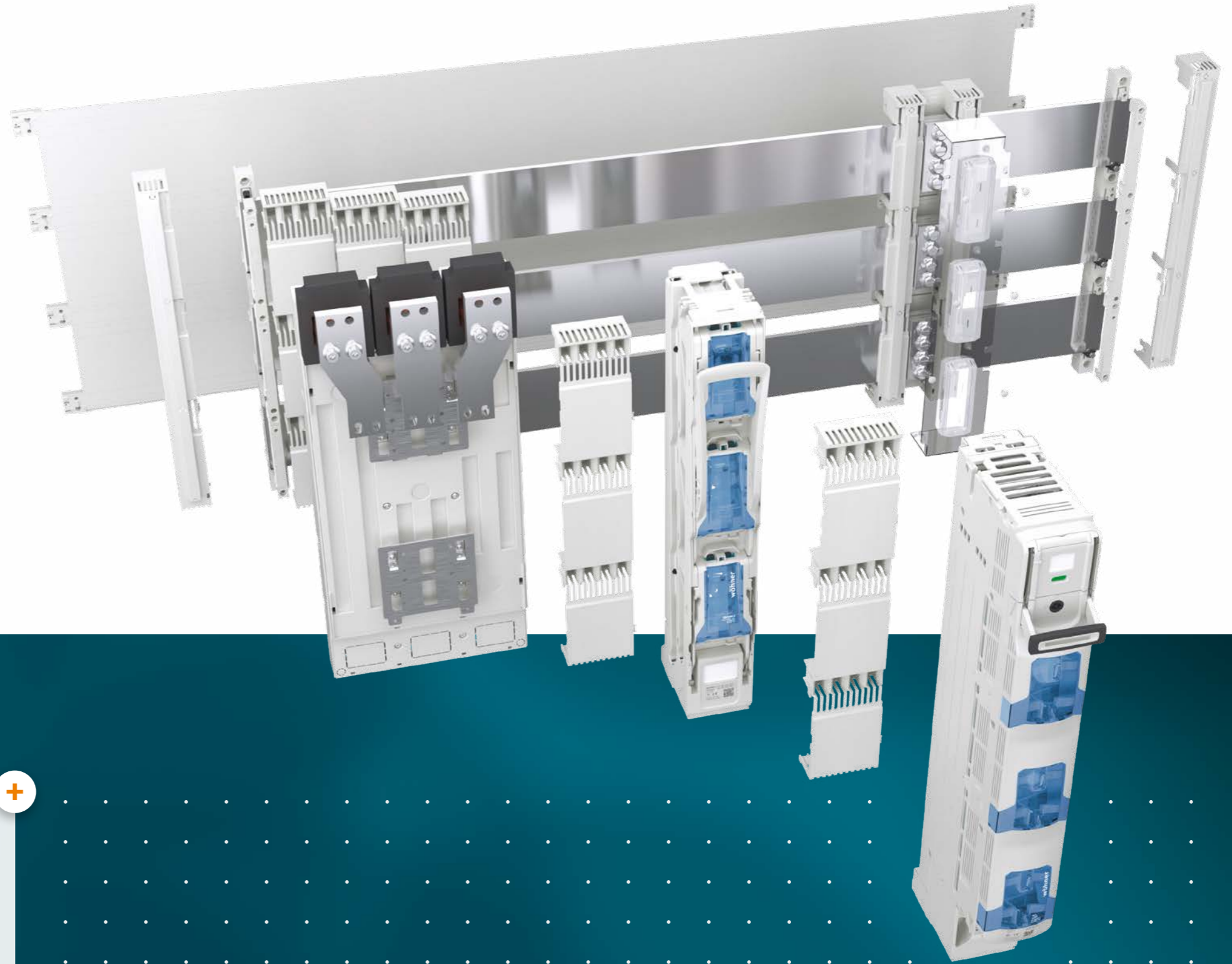

### OPTIMUM TOUCH-SAFE PROTECTION

The base plate profile for covering the back of the busbar system provides all-round protection. When accessing the electrical system from the rear during maintenance or extension work, the electrician is optimally protected from touching current-carrying busbar system components.



# TOUCH-SAFE PROTECTION RIGHT FROM THE START

## Busbar support and CrossLink®185Power covering system

The base of 185Power are the busbar supports which can be adjusted to various busbar widths. These allow the possibility for a drill-free mounting of flat bars. Thanks to the industrial production of 50 mm and 100 mm CrossLink® touch-safe protection covers, custom fabricated solutions are a thing of the past. The guidance of the CrossLink® busbar covers allows for an easy, safe positioning and contacting of components at any time. The risk of an externally initiated short circuit is minimised.

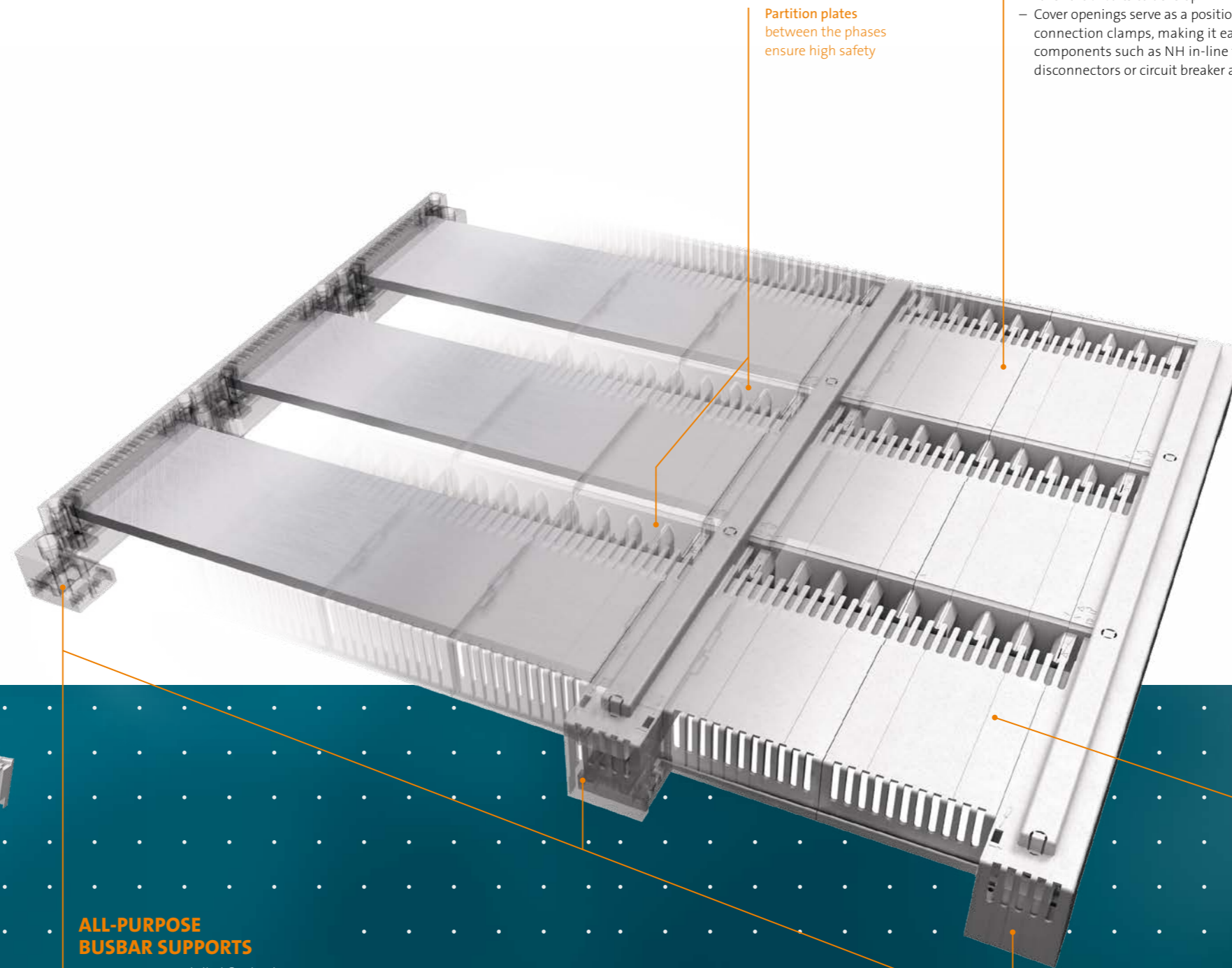

Partition plates between the phases ensure high safety

### FULLY TOUCH-SAFE PROTECTED BUSBAR SYSTEM

- Components can be mounted and removed from energized systems
- Base plate profiles make it possible for the busbar system to be covered from the back; Base plate fasteners are eliminated as a path for short circuits to develop
- Cover openings serve as a positioning aid for connection clamps, making it easy to position components such as NH in-line fuse-switch-disconnectors or circuit breaker adapters

### SLOT COVERS

- For covering the slots in the CrossLink®185Power touch-safe protection cover modules
- Protection class IP4x is achieved



100 mm wide 50 mm wide

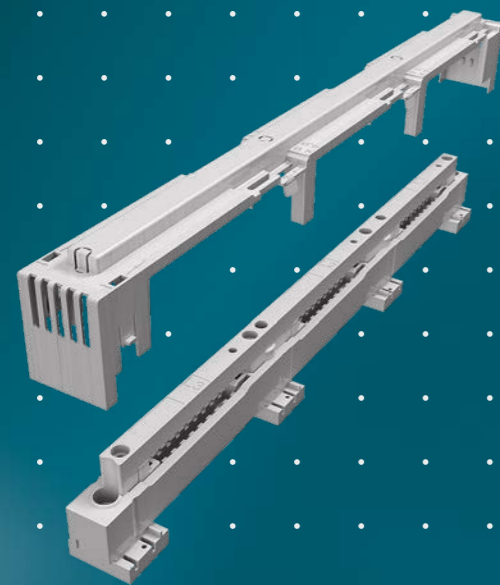

### ALL-PURPOSE BUSBAR SUPPORTS

- Mounting non-drilled flat busbars
- Accessories: Touch-safe protection cover for busbar supports
- Superstructuring possible with NH in-line fuse-switch-disconnectors – even with touch-safe protected busbar supports



### CrossLink®185Power TOUCH-SAFE PROTECTION COVER MODULE

- CrossLink®Technology provides optimum touch-safe protection and also dimensional scope for direct and secure connecting of components to the busbar system
- Modules in 50 mm and 100 mm widths are available
- Easy, tool-free mounting; However for safety reasons, tool-only disassembly
- For rear partitioning, base plate profiles can be snapped from the back onto the CrossLink®185Power touch-safe protection cover modules.

# THE EASIEST WAY OF CONNECTING

## CRITO®185Power connection components

Wöhner is breaking new ground in the area of connection technology. Both feeder and tap-off options are available with the CRITO®185Power connection rails or the CRITO®185Power connection modules. These solutions allow you to conveniently connect round conductors, flat conductors and cable lugs. With the individual components, you can apply currents of up to 1600 A directly to the busbar. Both connection options are fully compatible with the CrossLink® covering system.

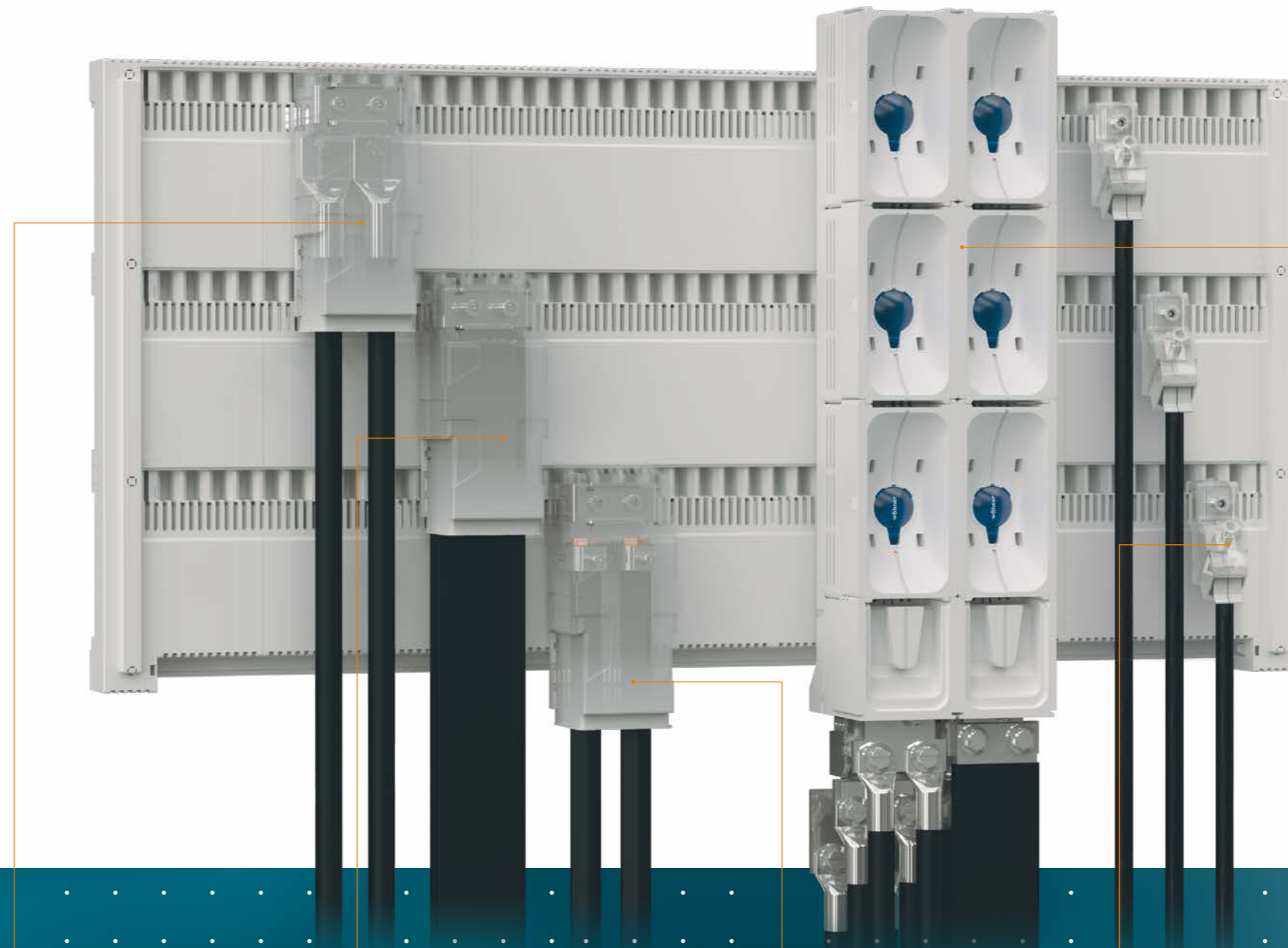

### CRITO®185Power CONNECTION RAILS

At only 100 mm wide, conductors, cable lugs and a laminated copper bar can be connected. Due to the standard supporting edge, the CRITO® connection rails can be easily combined with all QUADRON®185Power product family components. Just like other components, the connection rail can be mounted above the busbar support. The front access "service" covers allow convenient assembly and ease of maintenance.

### CRITO®185Power CONNECTION MODULES

Four touch-safe protected clamping methods are available for variable connections and connection of busbar systems:



**Conductor connection terminal** for copper and aluminium. It is suitable for 2 round conductors up to 300 mm².



**Flat conductor connection** for 1 or 2 laminated copper bars 50 or 80 mm wide.



**M12 screw type terminal.** This can be used for up to 4 cable lugs.



**Conductor connection terminal** with integrated cover for copper and aluminium conductors. It is suitable for 1 round or 1 sectored conductor up to 240 mm².

### CRITO®185Power CONNECTION RAIL

- Connection options:
- Laminated copper bar up to 80 mm wide
  - Conductor connection terminal for copper and aluminium conductors up to 300 mm²
  - Cable lugs: 4 x 240 mm² or 3 x 300 mm²



# THE FASTEST LINK BETWEEN EVERYTHING

## EQUES®185Power adapter for circuit breakers

Our adapters enable circuit breakers to be quickly and easily mounted on the 185Power system. They can be used for both feed- and tap-mounting of circuit breakers to the busbar system – something, of course, which applies to all customary circuit breakers up to 1600 A. With the EQUES®185Power adapter series, 185 mm busbar systems can be built without fuses.

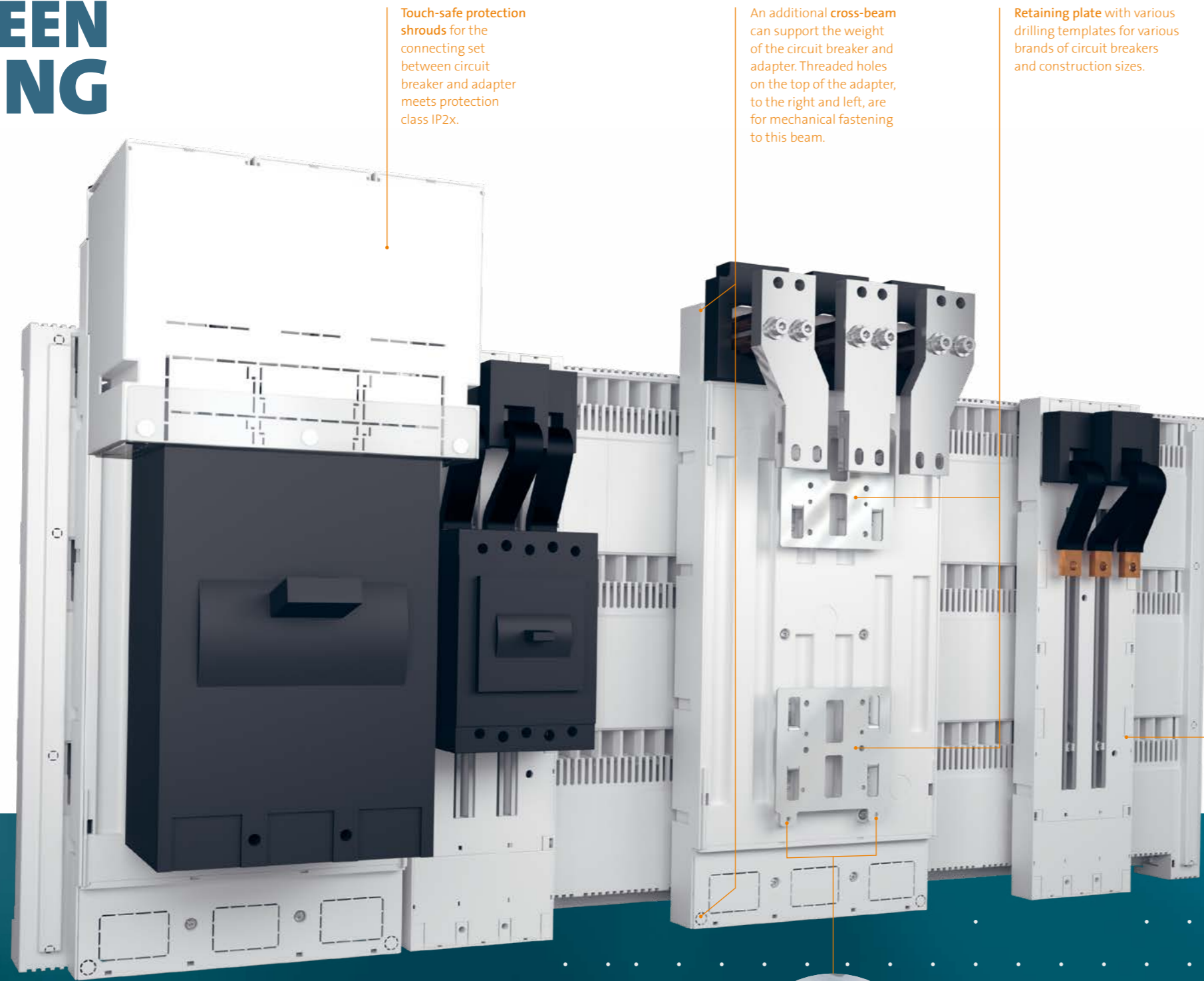

Touch-safe protection shrouds for the connecting set between circuit breaker and adapter meets protection class IP2x.

An additional cross-beam can support the weight of the circuit breaker and adapter. Threaded holes on the top of the adapter, to the right and left, are for mechanical fastening to this beam.

Retaining plate with various drilling templates for various brands of circuit breakers and construction sizes.



### EQUES®185Power ADAPTER FOR CIRCUIT BREAKERS

- Connection to the busbar system is possible at the top or bottom of the circuit breaker adapter
- The all-purpose retaining plates allow all standard circuit breakers to be mounted on the adapter
- Rated currents: 400 A, 630 A, 800 A, 1000 A, 1250 A, 1600 A
- Terminal shrouds are available for touch-safe protection of the connecting set as accessories. This provides IP2x protection from above.

## ENERGY MANAGEMENT AT ITS BEST

### Transformer measurement

To save space, three current transformers (CTs) can be directly integrated on the EQUES®185Power adapter. Transducers are easy to connect, and for efficient energy management purposes, provide data on power and consumption.

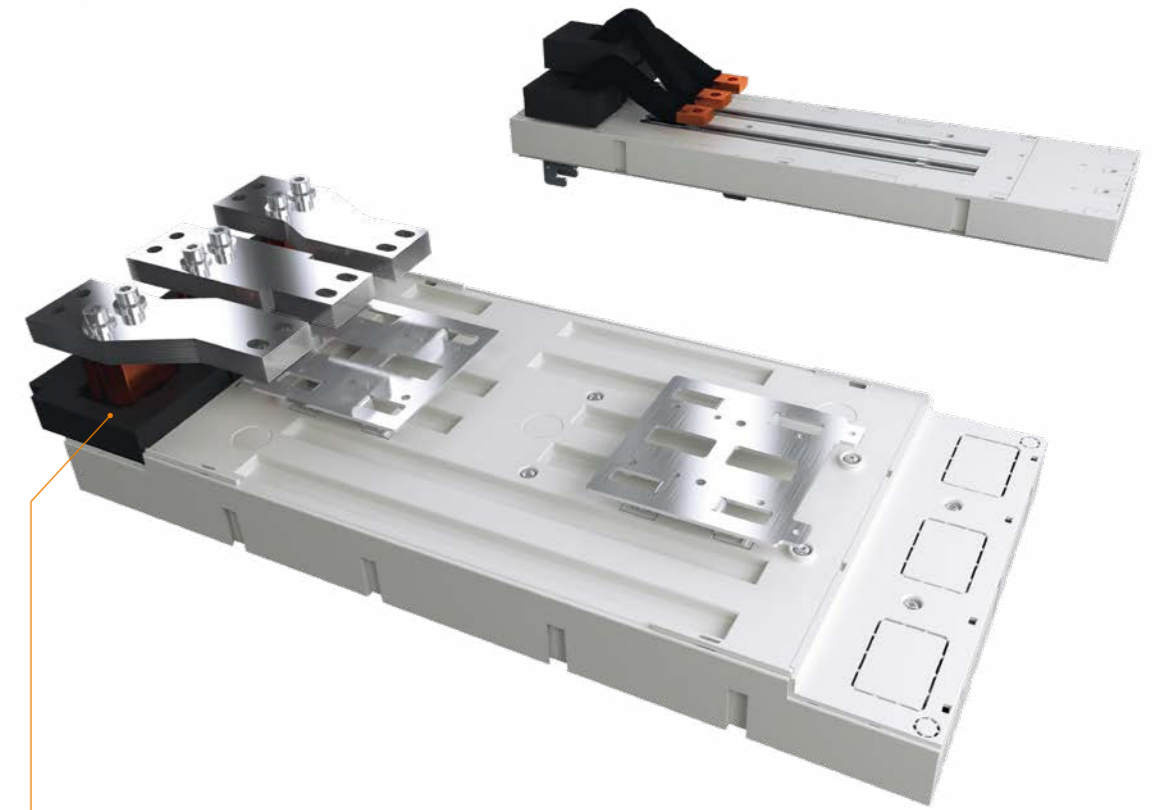

### ADAPTER MOUNTING

There are two possibilities for mounting the adapter onto the busbars: One of them is direct connection conventionally undertaken with screw clamp connection onto the drilled busbars. The other is the extremely convenient and time-saving variant with terminal clamp as a no-drill mounting on a touch-safe protected system. The EQUES®185Power adapter for circuit breakers up to 630 A also comes in a variant with a terminal clamp for mounting without CrossLink® touch-safe protection.

### CIRCUIT BREAKER MOUNTING

By using the mounting aids, all applicable circuit breakers can be easily and rapidly mounted onto the EQUES®185Power adapters and securely connected.



Mounting aid for easier mounting of the circuit breakers on the retaining plate of the adapter.



Profile rails with cage nuts. Numerous circuit-breakers up to 630 A can be easily mounted on the EQUES®185Power adapter due to C-profile rails with cage nuts that can be variably adjusted.

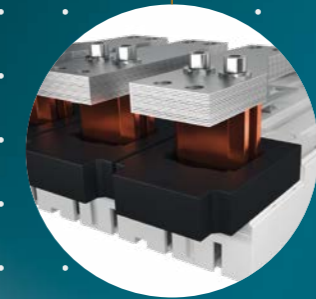

Integrated current measurement using current transformers.



**EQUES®185Power  
ADAPTER FOR CIRCUIT BREAKERS UP TO 630 A**

Besides the adapter for circuit breakers up to 1600 A, a small, 150 mm wide EQUES®185Power adapter is also available for the use of circuit-breakers up to 630 A.

The fact that the compact adapter is fitted with two C-profile rails with variably adjustable cage nuts means that the user reduces the number of adapter variants and can react flexibly to customer requirements.

One adapter – many applications. The adapter is fully compatible with the CrossLink® covering system and all existing system components.

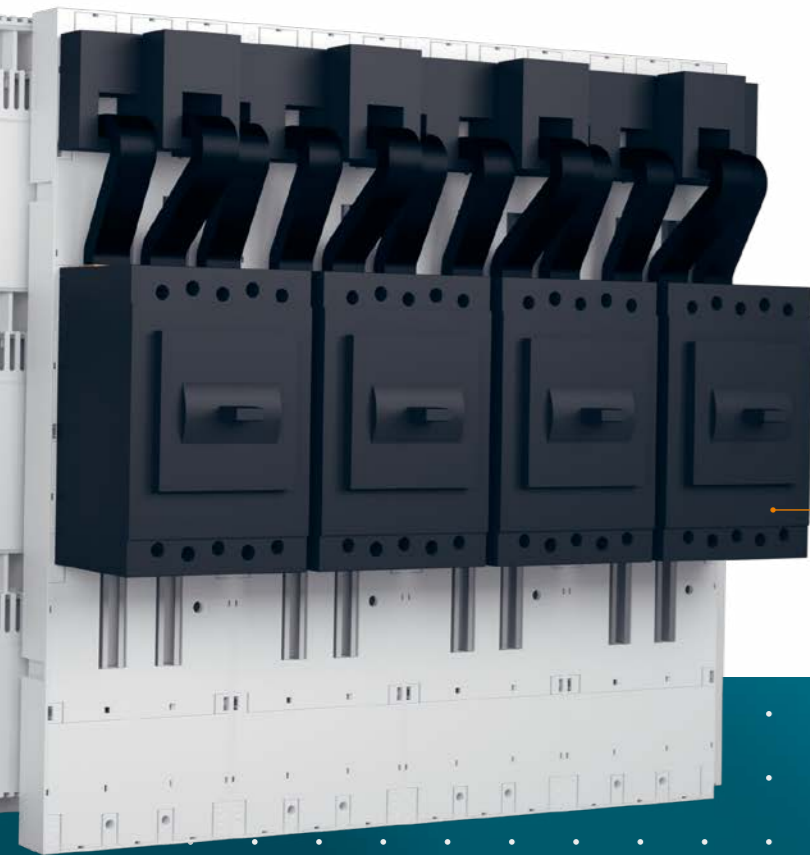

**Supporting edge for covering system**

When the circuit breaker is attached to the EQUES®185Power adapter, this results in the same level of 150 mm for the door cut-out as for the supporting edges of the QUADRON®185Power NH in-line fuse-switch-disconnectors.



# SWITCHING OR DISCONNECTING

## QUADRON®185Power Speed, the NH in-line switch-disconnector-fuse

QUADRON®185Power Speed, the in-line switch-disconnector-fuses, in sizes 00 to 3 with an operator-independent snap-action switch mechanism, now complement the 185Power system. With the NH in-line switch-disconnector-fuse, the user also benefits from the numerous advantages, with which he is already familiar from the NH in-line switch-disconnector-fuse: Quick and easy mounting, convenient line terminal, and integrated transformer.

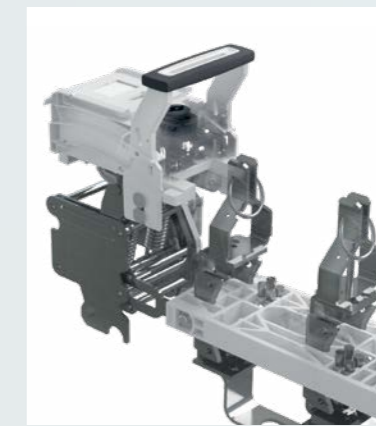

**OPERATOR-  
INDEPENDENT  
SWITCHING**

Regardless of who is moving the lever – the automatic snap-action switch mechanism of the QUADRON®185Power Speed, NH in-line switch-disconnector-fuse switches with a defined speed. Danger from arcing is therefore effectively excluded. The snap-action switch mechanism always disconnects both NH fuse-link contacts from the voltage-carrying components. This double break ensures even more safety.



# MIXED POSSIBILITIES

## Multiple possibilities in one system

Mixed installation of switch-disconnector-fuses, in-line switch-disconnectors and circuit breakers, with other components in the same control panel is now possible. With the modular 185Power system, the various components can be combined on a single 185 mm busbar system, everything fits perfectly together. You also save space thanks to the narrow width and the gap free mounting of the strips. Even retrofits or extensions to the system are problem-free and possible at any time, thanks to the modular system.

### YOUR ADVANTAGES AT A GLANCE

- + Operator-independent snap switching mechanism with double disconnection
- + Mounting under voltage possible
- + Safety through full touch-safe protection thanks to CrossLink®Technology
- + QUADRON®185Power Speed, NH in-line switch-disconnector-fuse installed vertically
- + Top and bottom connection possible
- + Mixed installation on a single busbar system
- + Space-saving thanks to compact, seamless construction
- + Time-saving due to simple mounting and connection
- + Highly flexible – subsequent changes and extensions easily possible

## SEPARATE CABLE CHAMBER NOT REQUIRED WITH 185Power Speed

When you want to use conventional NH switch-disconnector-fuses as tap-offs but do not have enough space for the additional cable chamber (picture right).

With the horizontal busbar system 185Power and the NH in-line switch-disconnector-fuses Speed mounted vertical on it, you can get a more compact panel (Fig. page 19).

Another advantage: The vertical structure of the NH in-line switch-disconnector-fuses Speed ensures that any heat transfer between units is significantly reduced.

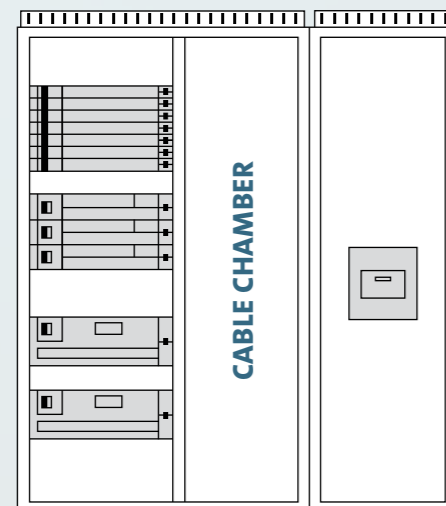

Flag indicator shows the switching state via a red-green field

### QUADRON®185Power Speed NH IN-LINE SWITCH-DISCONNECTOR-FUSE Size 1 - 3

- NH in-line switch-disconnector-fuse project through the control panel door; this means that operation without opening the control panel door is possible

### QUADRON®185Power Speed NH IN-LINE SWITCH-DISCONNECTOR-FUSE Size 00

- Available in two depths
- NH in-line switch-disconnector-fuse Speed project through the control panel door; this means that operation without opening the control panel door is possible

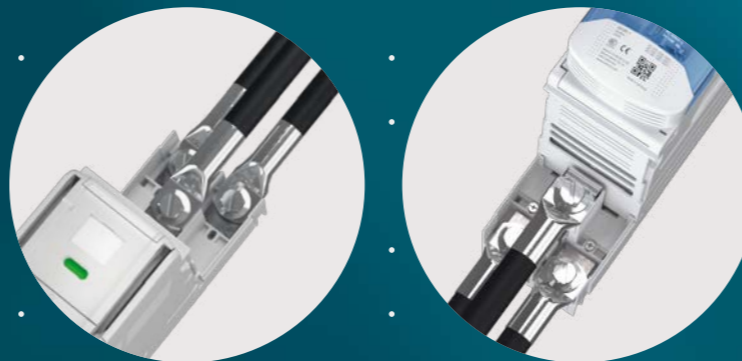
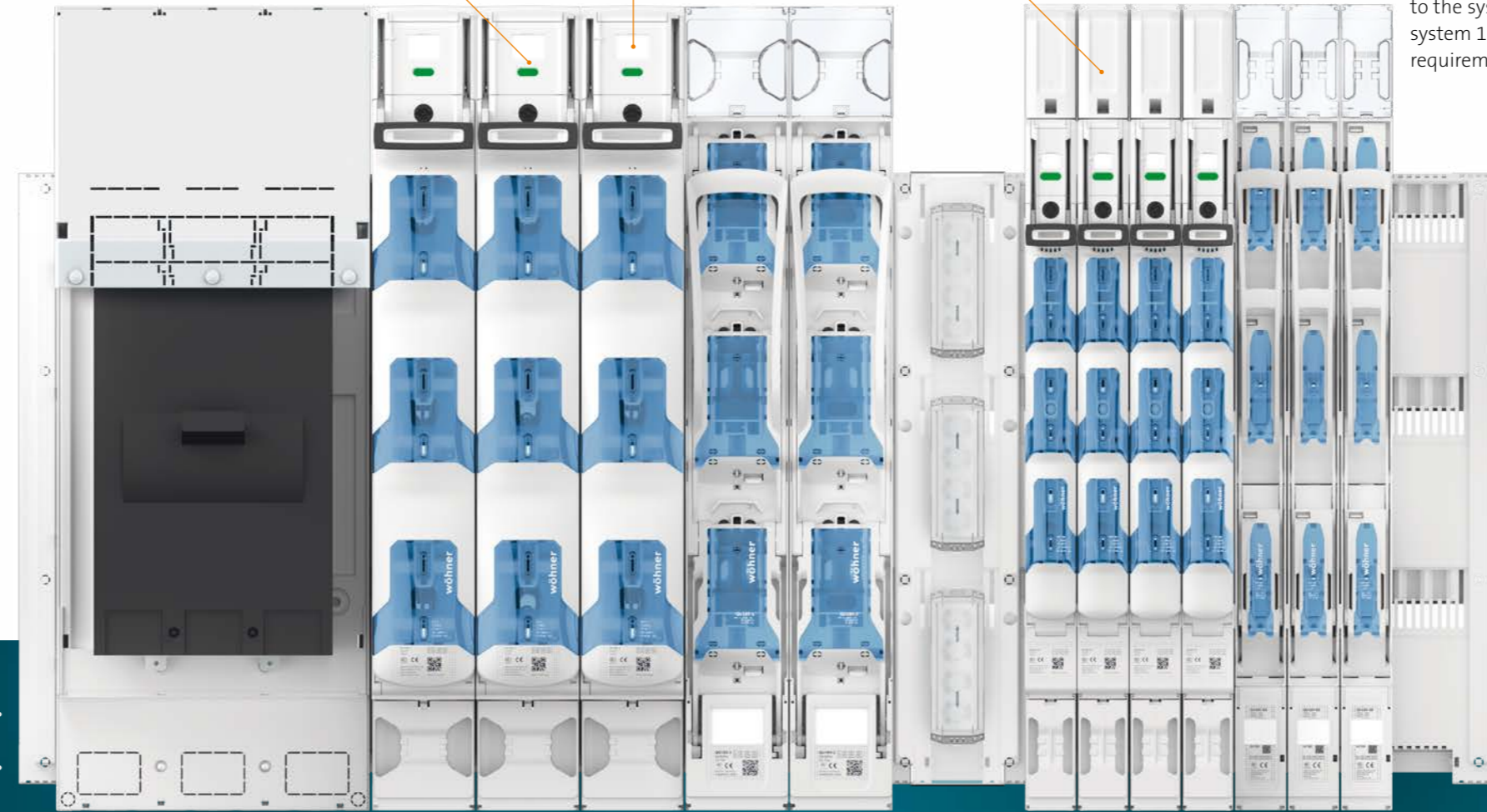

Top or bottom connection. Keep your design flexible. With all QUADRON®185Power Speed you can have the cable outlet at the top or the bottom.

## SAVE SPACE – REDUCE COSTS

### Low voltage distribution with the 185Power system

The 185Power system lets you implement cost-efficient low voltage distribution systems. The mixed tap-off installation with varying protection on one busbar system in a standard control panel saves space, reducing your overall system costs. The modular design enables order and overview. Even if yet more changes are required to the system at a later date, you are on the safe side with this system 185Power. This lets the user remain flexible, even for future requirements.

### SAFETY PLUS: LOCKING AND SEALING

QUADRON®185Power Speed, the NH in-line switch-disconnector-fuses Speed, can be secured in a number of ways. All strips can be locked with padlocks of up to a maximum of 7 mm (NH00) or 8 mm (NH 1 - 3) shackle diameter. Unauthorized activation of a strip can effectively be prevented. Seal application provides additional security against manipulation.



### COVER LOCKING

The lock integrated within the switch-disconnector-fuse cover can easily be locked with a control panel key. Thanks to the possibility of access through the closed control panel door, this function secures the QUADRON®185Power Speed against unauthorized opening of the fuse space!



### STANDARD-COMPLIANT SYSTEMS

As the snap-action switch mechanism in combination with the specially designed switching contacts meets the AC 23B utilisation category under the IEC / EN 60947-3 device standard, the QUADRON®185Power Speed, the NH in-line switch-disconnector-fuses are suitable as Supply Circuit Disconnecting Means in accordance with standard IEC / EN 60204-1.

Thanks to the AC 23B utilization category, the QUADRON®185Power Speed, the NH in-line switch-disconnector-fuses can also be used for switching of motor and other inductive loads.



## MAXIMUM CAPACITY ON THE BUSBAR

### QUADRON®185Power, the NH in-line fuse-switch-disconnectors

Easily fits any combination of the QUADRON®185Power NH in-line fuse-switch-disconnectors of sizes 00 to 3 to the 185Power system. Based on application specific requirements, the NH in-line fuse-switch-disconnectors can be conveniently, quickly and securely mounted with mechanical clamps without drilling or bolted directly to a drilled busbar.

#### YOUR BENEFITS

- + Hinged windows for time-saving mounting and no need to dismantle the NH in-line fuse-switch-disconnectors
- + Easily accessible cable terminal compartment
- + Lid can be locked in the open and closed positions
- + Lid position monitoring with two signaling switches per lid
- + Easy switching thanks to ergonomic operating handle
- + Considerable scope for cable connecting
- + Top and bottom connection possible
- + Lid can be lead-sealed

#### QUADRON®185Power NH IN-LINE FUSE-SWITCH-DISCONNECTOR

##### Size 00 flat version

- 1- and 3-pole switchable
- Shallow depth allows for a space saving design
- Adapter available for mounting two QUADRON®185Power NH in-line fuse-switch-disconnectors size 00

##### high version

- 1- and 3-pole switchable
- In the overall height compatible with size 1 - 3 NH in-line fuse-switch-disconnectors
- Optimized fulcrum position for easy fuse removal

#### QUADRON®185Power NH IN-LINE FUSE-SWITCH-DISCONNECTOR

##### Size 1 - 3

- 1- and 3-pole switchable

#### QUADRON®185Power DOUBLE NH IN-LINE FUSE-DISCONNECTOR

##### 2 x NH Size 3

- 1250 A
- Sufficiently large terminal compartment cover
- 4 cable lugs per phase can be connected

#### QUADRON®185Power NH IN-LINE FUSE-BASE OPEN VERSION

##### Size 00 - 3

- Mounting possible in a touch-safe protected condition
- Optional labelling on phase separating bar



#### LOCKABILITY

NH in-line fuse-switch-disconnector size 00

- 3-pole switchable, closed with 3 padlocks, 5 mm shackle diameter
- 3-pole switchable, open with 2 padlocks, 5 mm shackle diameter
- 1-pole switchable, closed with 1 padlock per lid

NH in-line fuse-switch-disconnector sizes 1 - 3

- 1- and 3-pole switchable, closed with 3 x 2 padlocks, 5 mm shackle diameter
- 3-pole switchable, open with 3 x 2 padlocks, 5 mm shackle diameter



#### PARKING POSITION

The lids of the 1-pole switching NH in-line fuse-switch-disconnectors can be unhinged. A safe parking position is assured from them being turned over and re-mounted. The lid can no longer be inadvertently closed.



#### MORE VARIANTS OF THE QUADRON®185Power NH IN-LINE FUSE-SWITCH-DISCONNECTORS

- Size 00 to 3 available with electronic fuse monitoring
- Available with LED fuse indicator for indicating the fuse condition

#### SWITCHING EVEN THROUGH THE CONTROL PANEL DOOR

Thanks to the greater depths, the QUADRON®185Power Speed, NH in-line switch-disconnector-fuses can also be operated when the control panel door is closed.

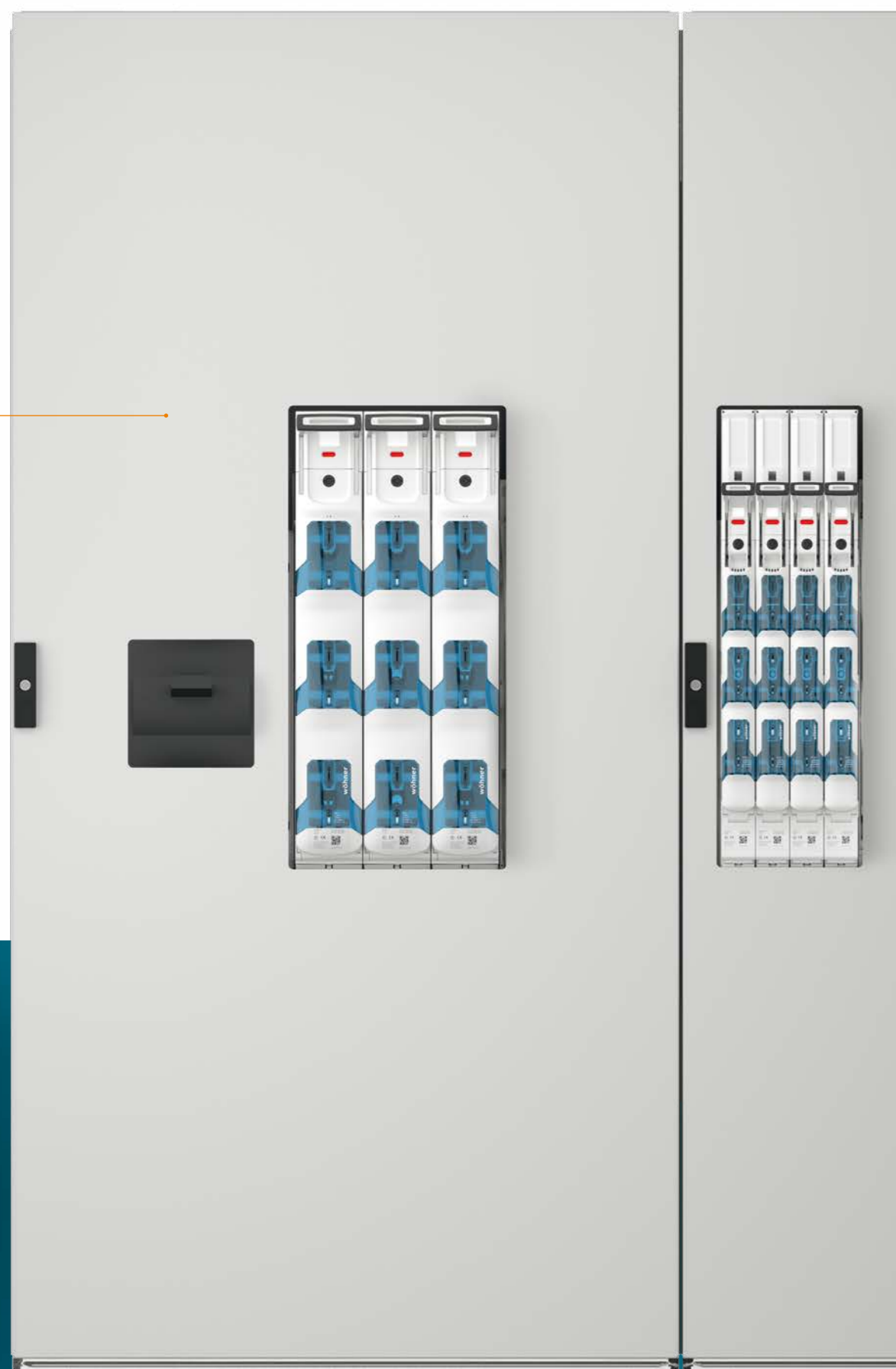

Simple fuse withdrawal and insertion from optimally positioned fulcrum point of the fuse carrier of the size NH 00, high version, NH in-line fuse-switch-disconnector.

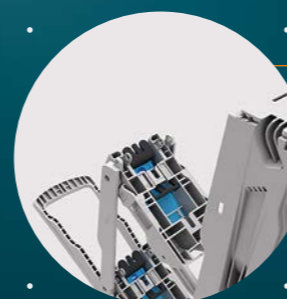

Easy fuse unlocking



## COMPLETE FLEXIBILITY IN MOUNTING

### One busbar – three connection possibilities

The innovative Wöhner 185Power system opens up a whole new dimension in terms of ease of mounting for NH in-line switch-disconnector-fuses and NH in-line fuse-switch-disconnectors. All sizes 00 - 3 models can be mounted in various ways to the busbar:

- ① **No-drill mounting on the CrossLink®-protected busbar system using a terminal clamp**
- ② **No-drill mounting with a terminal clamp directly to a busbar structure without CrossLink® covers**
- ③ **Mounting with a screw type terminal (M8 / M12) to drilled busbar**

All NH in-line switch-disconnectors can be used with the outgoing terminals at the top or bottom. In the NH in-line fuse-switch-disconnectors, just the base needs to be rotated. The strip housing can be re-fitted in the same position and no change is required to the covering system. In the NH in-line switch-disconnector-fuses there are two different versions available for top or bottom outgoing terminals.

### NO DISMANTLING – MOUNTING CONVENIENCE



– The NH in-line fuse-switch-disconnectors can be directly mounted on the busbar through a hinged window – without them having to be dismantled beforehand

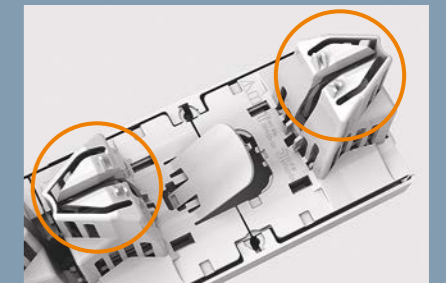

– NH-contacts are IP10 protected with the lid dismantled  
 – IP20 touch-safe when completely assembled

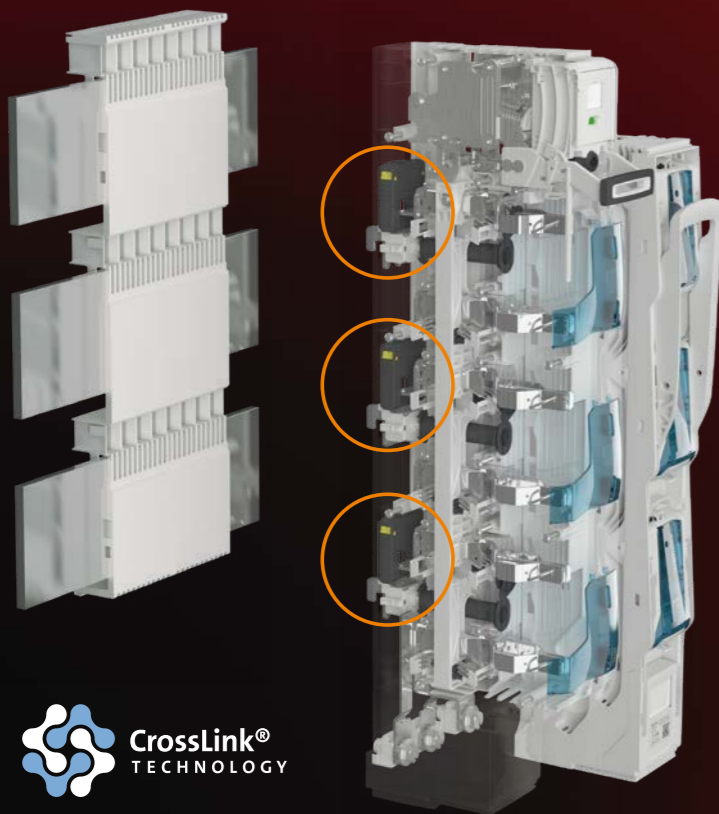

### Integrable current measurement

- For QUADRON®185Power and QUADRON®185Power Speed
- Easy mounting of the current transformers in the back of the housing
- No change in the installation depth of the switching devices



### ① Mounting with terminal clamp on the CrossLink® touch-safe protection cover

In order to not unnecessarily interrupt the operation of equipment, terminal clamp-deployed mounting can also be done in an energized state. This ensures maximum safety for a qualified electrician.

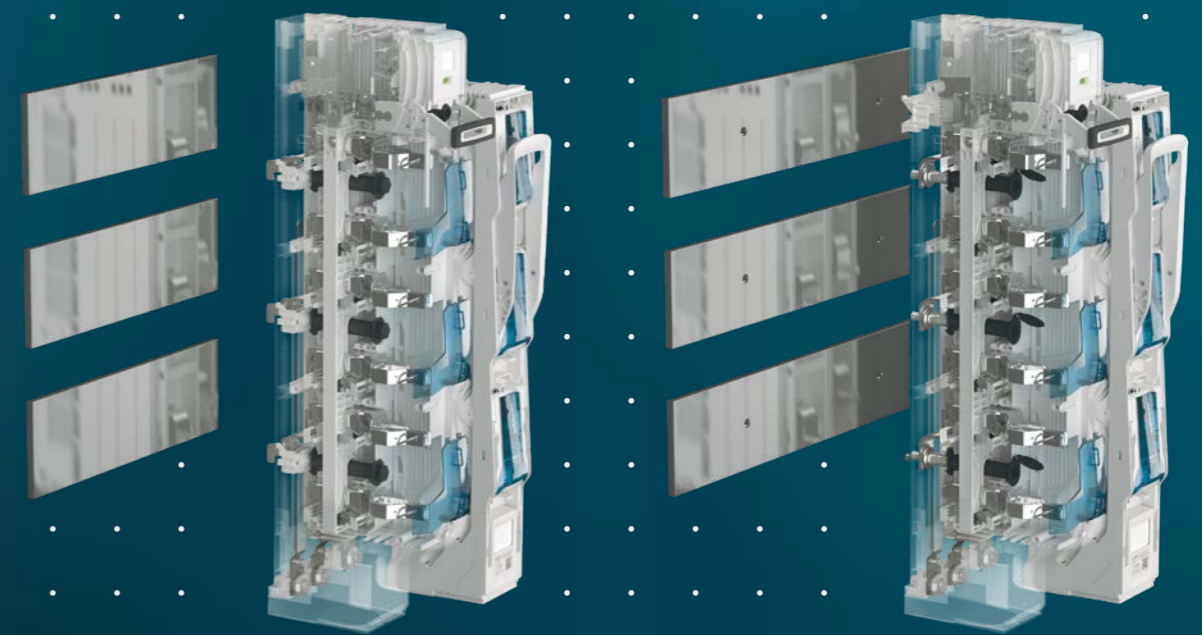

### ② No-drill mounting with a terminal clamp

Mounting with terminal clamps to a system without CrossLink® touch-safe protection is also possible. In so doing, the device can be easily attached onto the busbar without this added level of protection.

### ③ Mounting with M8 / M12 screw type terminal

Three M8 / M12 screws can be used to fix the NH in-line switch-disconnectors onto either drilled or punched busbars in the traditional method after the added labour of drilling holes in the busbars.





## VARIABILITY IN THE CONNECTION METHOD

### Easily accessible terminal compartment

Simple connection increases efficiency. For all NH in-line switch-disconnector-fuses and NH in-line fuse-switch-disconnectors, vast importance was placed on an easily accessible terminal compartment. Depending on the type, the cover can be either opened or pushed out and removed – for all connection types.

## INNOVATIVE COOLING AND VENTILATION

### Effective discharge of switching gases

The full-length lateral ducts of the QUADRON®185Power NH in-line fuse-switch-disconnectors produce a kind of draw-off chimney which acts as a cooling and ventilation system for the pinpoint discharging of switching gases and heat. The need for arcing chambers is no longer necessary thanks to this simplified and effective discharge opening method.

#### CONNECTION ARRANGEMENT 1

##### Box terminal

No additional terminal compartment cover is needed when using a box terminal for the connection.



#### CONNECTION ARRANGEMENT 2

##### Drawer-type method

The drawer-type method allows for a considerable variation in connections. Connection can be flexibly made with either nut or stud bolt – depending on installation requirements. An additional terminal housing cover is needed when using a cable lug for the connection. These covers can be linked in series to form longer covers.

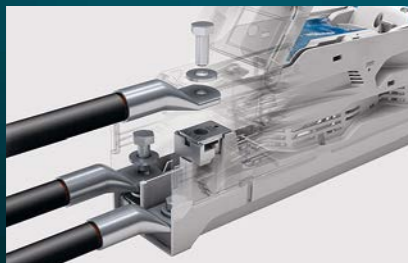

Screw type terminal with nut insert



Screw type terminal with a stud bolt

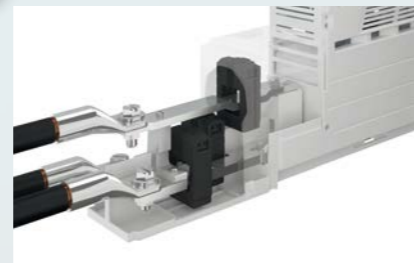
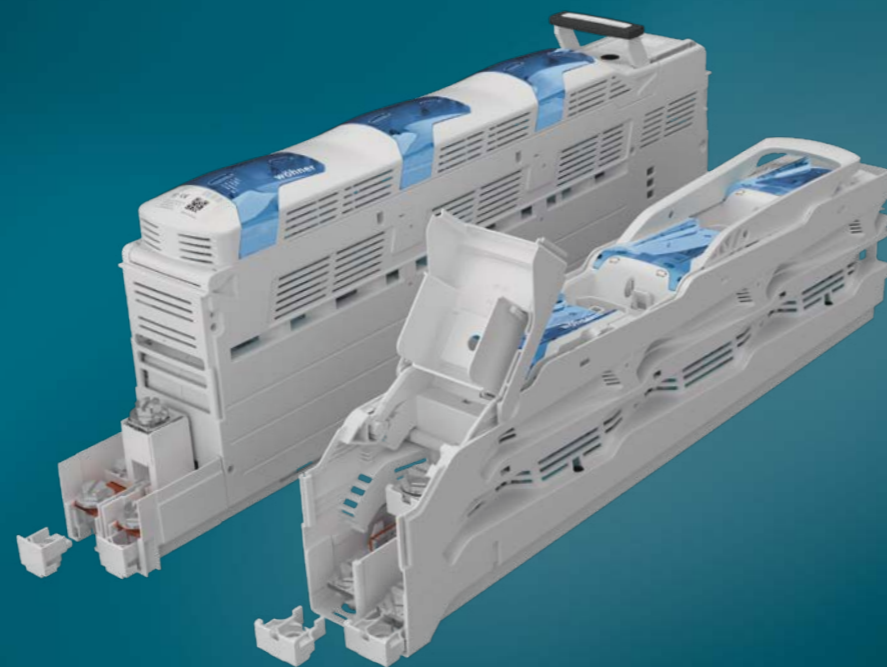

#### CURRENT TRANSFORMER MODULE FOR MOUNTING IN THE CONNECTION AREA

- For QUADRON®185Power sizes 1 to 3, QUADRON®185Power Speed sizes 1 to 3 and CRITO®185Power connection rail 800 A
- Easy installation in the connection area
- Perfect for retrofitting, installed current transformers still accessible
- Various current transformer versions, also for utility billing purposes
- Touch-safe protection, with optional terminal cover cap

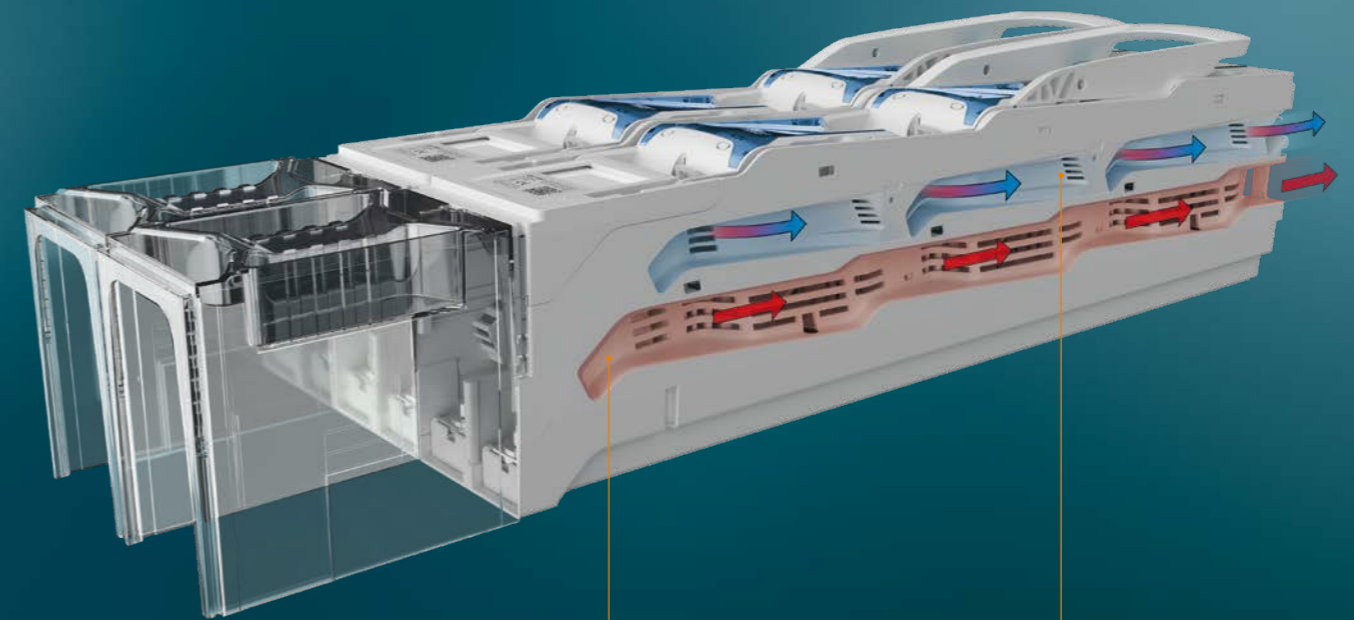

Two QUADRON®185Power NH in-line fuse-switch-disconnectors fitted next to each other create at their centre a **full length ventilation duct** which – like a chimney – discharges hot air.

**Pinpointed diversion of the switching gases** for rapidly extinguishing arcs.

# LEAVE BEHIND A GOOD IMPRESSION

The attractive appearance of your switchgear assembly is what ultimately leaves a lasting impression of you on your customer.

The 50 mm and 100 mm grid units of the CrossLink® touch-safe protection covers make planning easier and provide you with a maximum degree of safety. For their part, the matched components raise safety levels and simplify installing, maintaining, servicing and extending the system. Deployment of the 185Power system is synonymous with both skill and a sense for operating efficiency.

## Measuring current transformers – the basis for energy efficiency

Energy management is becoming increasingly important in order to be able to operate buildings and plants economically. For this purpose, many measuring points within the energy distribution systems must be available in modern switchgear assemblies. The measurement is carried out with current transformers. The values can be displayed directly in the energy distribution systems or further processed in an energy management system via measuring transformers. In the 185Power system there are a number of possibilities to integrate current transformers easily and quickly. Retrofitting is possible without requiring additional space. Depending on the application, current transformers are available in all common measuring ranges and accuracy classes, also for utility billing purposes.

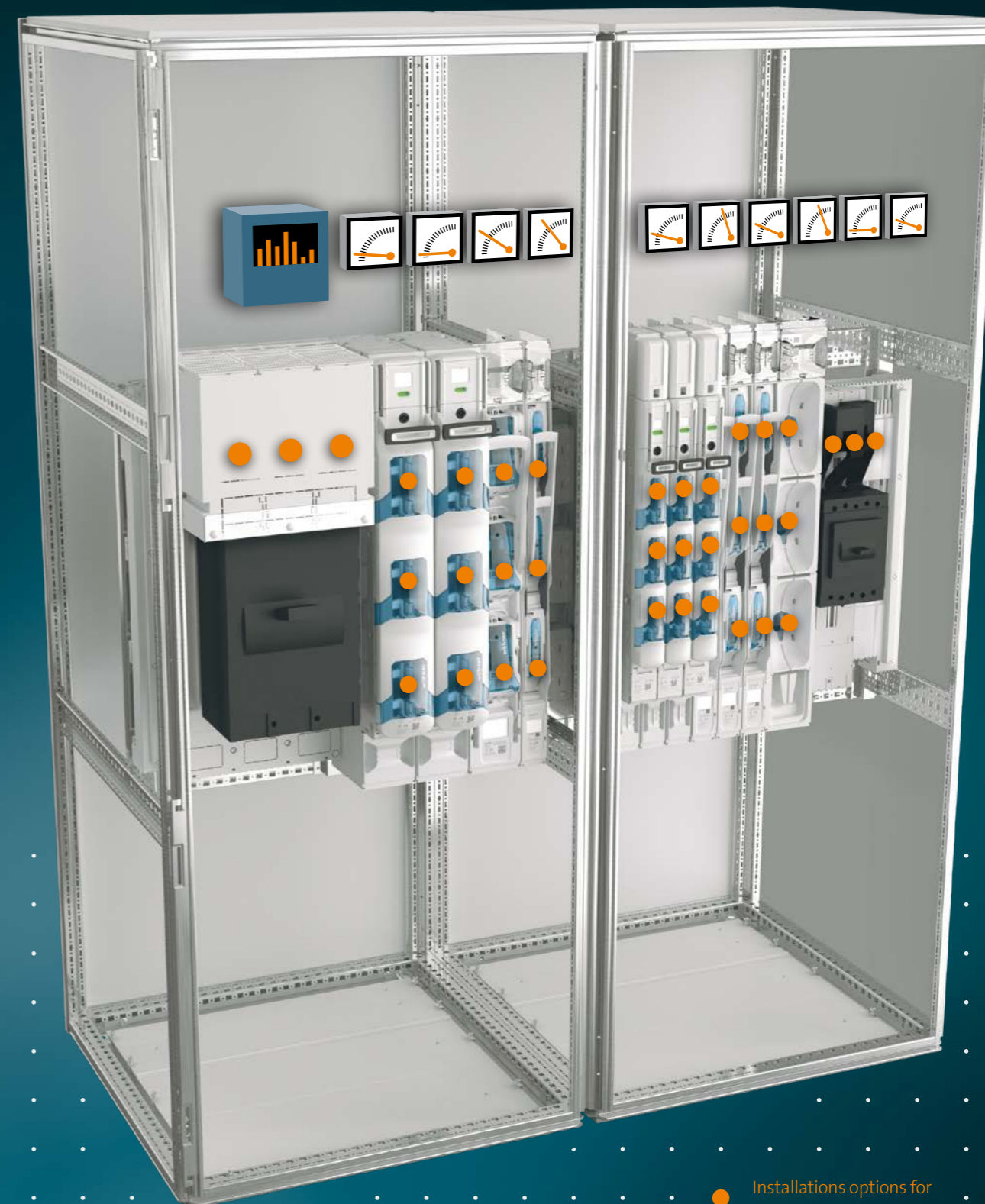

## PRETTY SMART! OUR CONFIGURATOR.



### Configurator

- + 3D planning tool with realistic appearance
- + Guidance by technical parameters
- + Technical documentation

### Augmented Reality

- + Presentation of a virtual control cabinet in a real room
- + Import of projects planned by yourself in the configurator is possible

● Installations options for current transformers



An overview of the articles is available on the Wöhner website in **Media/Downloads/Manual/185Power**



**Headquarters**  
**Wöhner GmbH & Co. KG**  
Elektrotechnische Systeme  
Mönchrödener Straße 10  
96472 Rödental  
Germany

Tel. +49 9563 751-0  
info@woehner.com  
woehner.com

