



THORNE &
DERRICK
INTERNATIONAL

Thorne & Derrick
+44 (0) 191 410 4292
www.powerandcables.com



A CRH COMPANY

STAKKAbox™ Quad for Openreach



STAKKAbox™

Quad



STAKKAbox™ Quad

STAKKAbox™ Quad is a range of modular and structural preformed access chambers that provide a modern alternative to traditionally brick built chambers. This system provides contractors with a means of constructing access chambers safely, quickly and inexpensively, whilst offering superior build quality, reduced defects and enhanced site safety performance over traditional methods.

STAKKAbox™ Quad is the only modular access chamber approved for use on Openreach networks, available in 102, 104 and 106 sizes.

Due to its twinwall design, individual sections are lightweight meaning they can be manually lifted and stacked on top of each other to reach the specified depth required. The STAKKAbox™ Quad chamber system also comes with a wide range of X-TRAS™ chamber accessories and AX-S™ access covers to provide a complete network access system.

Using the Quad system, complete chambers can be constructed from excavation to reinstatement in less than one hour.

Contents

STAKKAbox™ Quad	02
Features & Benefits	04
Product Profile	06



Features and Benefits

STAKKAbox™ Quad comprises of 150mm deep sections stacked to the specified height on top of a concrete or Type 1 base.

Cover Options

Concrete Infill (B125) & Recessed (B125)

Sub-security Plate

Options for added security

Drop-in Furniture & Steps

Cable management and steps are fitted by dropping the accessories into pre-formed pockets. These allow accessories to be retrofitted after installation without mechanical fixing.

Lightweight

STAKKAbox™ Quad chambers are built by stacking sections to the required depth. Each section weighs under 25kg, making it suitable for a single person to lift under manual handling guidelines.

Rapid Assembly

STAKKAbox™ chambers are significantly faster to install than conventional alternatives, with complete installations typically taking less than one hour. This results in reduced costs for the installer.

Improved Build Quality

Brick built boxes regularly produce variable build quality standards resulting in frequent rejection by Openreach inspectors. The use of STAKKAbox™ Quad eliminates this variability and offers a consistent installation every time.

Easy to Overbuild

Quad can be used to retrofit chambers over an existing network or for replacing chambers that have been damaged or need to be enlarged. Where required, ring sections can be cut to bridge over or around existing networks or obstacles.

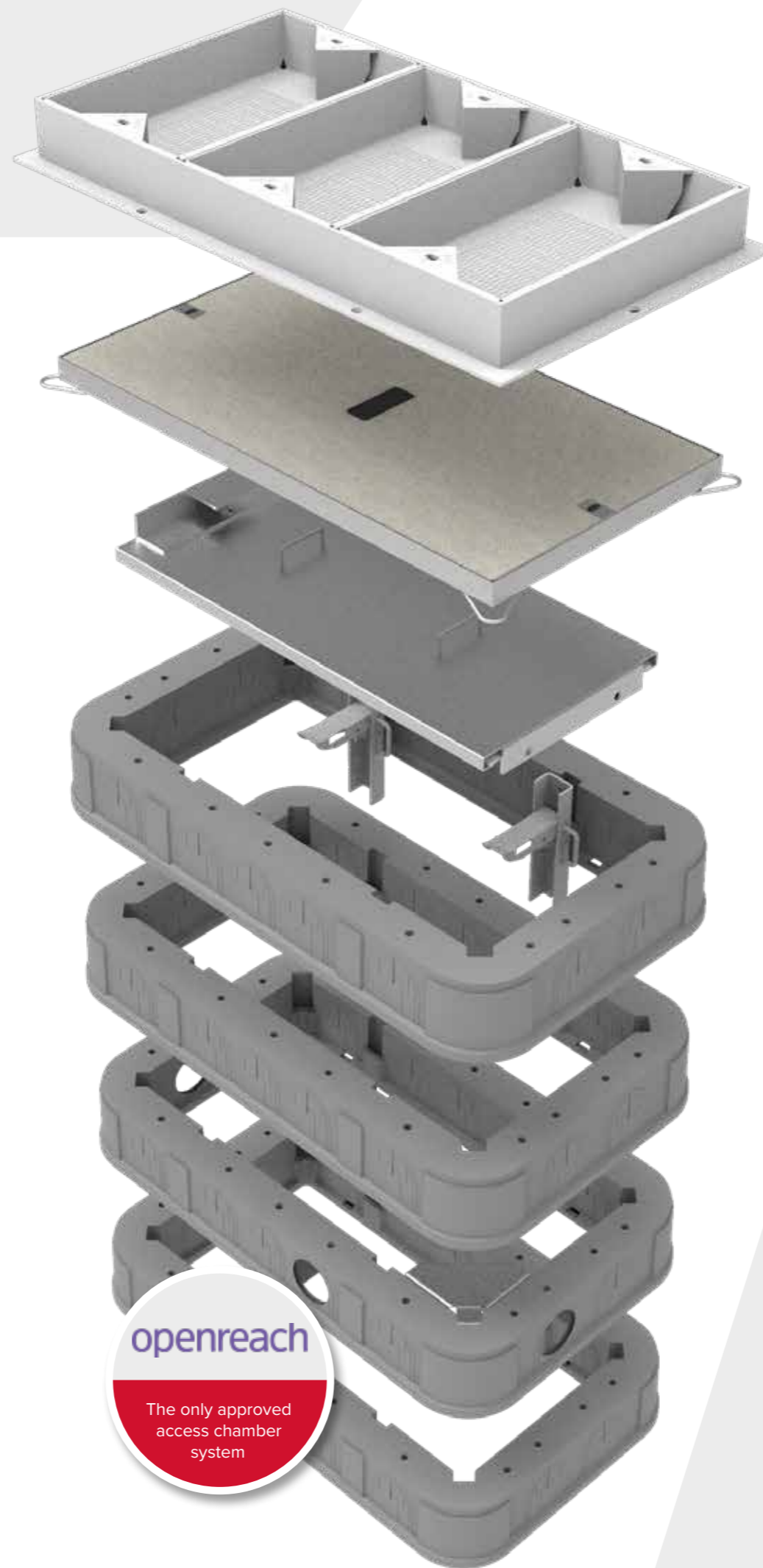

All Weather Construction

Unlike with brick-built chambers where freezing temperatures can stop work, Quad can be installed in all types of weather.

Easy to Install

No specialist equipment or plant is required in order to install the chamber and there is no need for specialist box builders.

Integrated Systems

Chambers are built to the required depth by adding 150mm sections. Each ring section is castellated to positively interlock with the unit above and below. Cover options and accessories can then be added to complete the system.

Base Options

A base can be constructed from: 50mm of dry mix concrete on 100mm of compacted Type 1; 150mm of compacted Type 1; 150mm deep concrete base (C20 or dry mix) or 50mm of ready mix concrete on 100mm of compacted Type 1.

Easy-cut Duct Entries

Duct entries can be cut as and where required using a hole saw mounted on a cordless drill. The chambers incorporate guides which identify drilling points to ensure correct duct spacing.

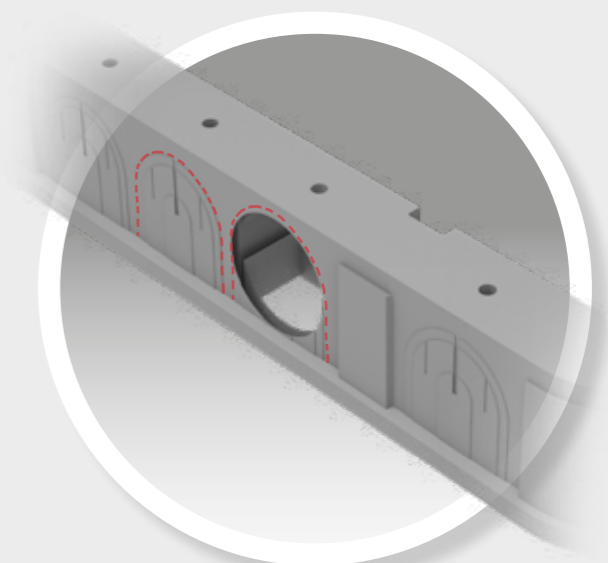

Product Profile

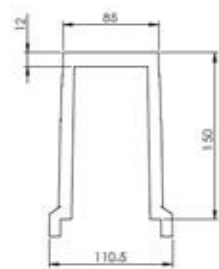
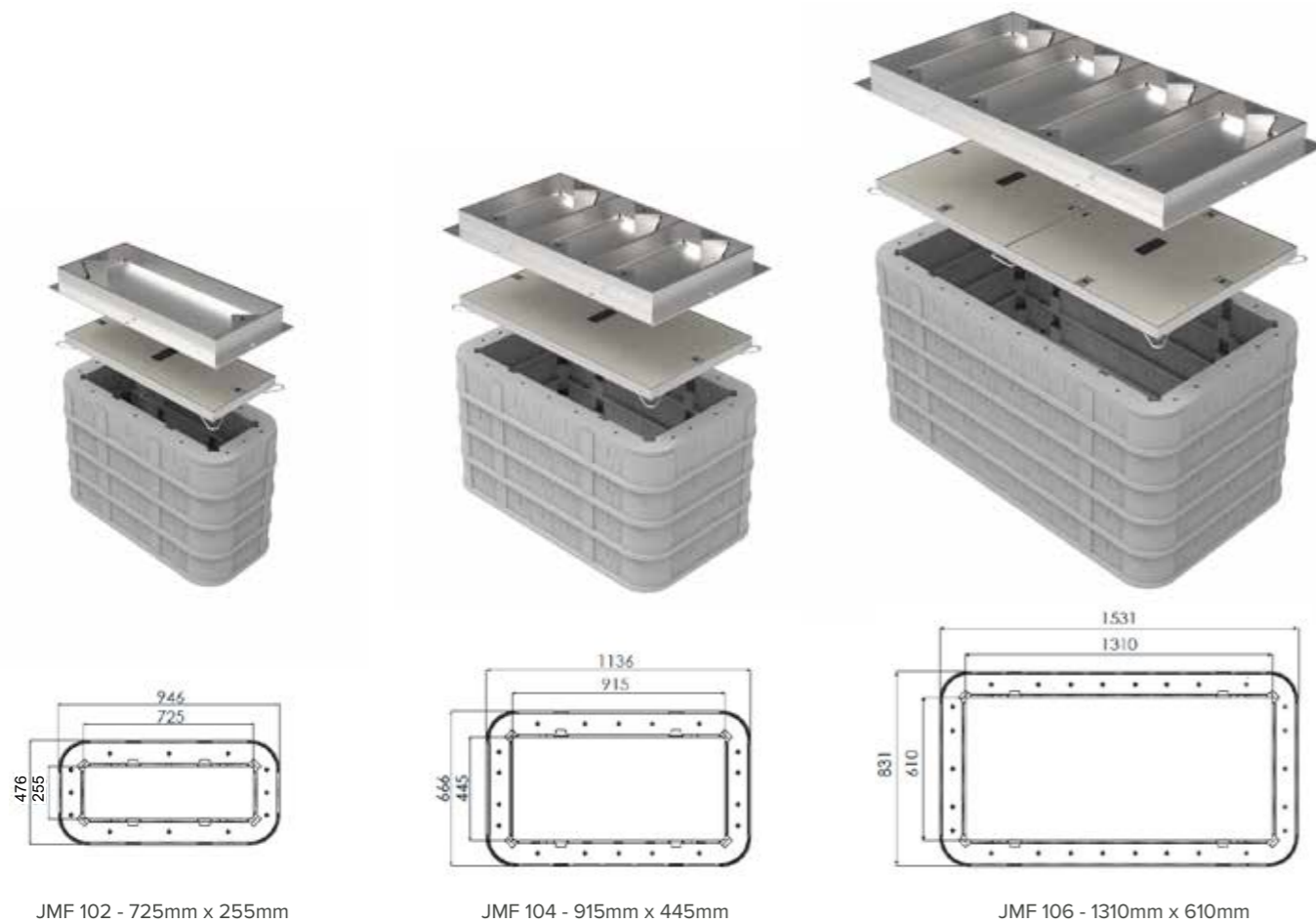

Cross Section

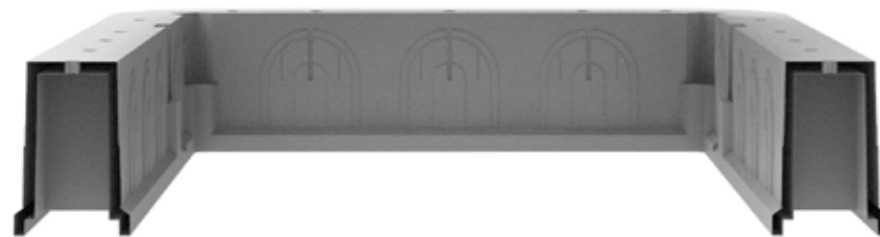

BT Code	Internal Dimensions	Depth per section	Typical depth of chamber	Weight per section	Cubis Product Code
JMF 102	725mm x 255mm	150mm	600mm	6.64kg	CPQBQ2-07250255-000000000
JMF 104	915mm x 445mm	150mm	600mm	13.62kg	CPQBQ4-09150445-000000000
JMF 106	1310mm x 610mm	150mm	750mm	18.79kg	CPQBQ6-13100610-000000000

Cover Options

Designed to provide seamless integration with the STAKKAbox™ range of chambers AX-S™ cover range offer flexibility in size and design with options for locking.

AX-S™ Recessed



- 86mm deep to suit 60mm block
- Can be filled with any material
- Tapered cover and centralised lifting keyholes
- Can be locked
- Kitemarked by BSI
- The only approved Recessed cover for Openreach, Virgin Media, CityFibre and other network operators

AX-S™ Concrete Infill



- Covers lift and slide out
- One-person operation
- No inherent scrap value
- Can be locked
- Kitemarked by BSI
- The only approved concrete cover for Openreach, Virgin Media, CityFibre and other network operators

Openreach Code	Recessed	Concrete Infill
JMF 102	■	■
JMF 104	■	■
JMF 106	■	■

Accessories

Available pre-fitted or as an add-on, the X-TRAS™ accessories range improves the performance of access chambers, enhances existing systems, reduces build time and ensures safety.

Cable Management



Step



Openreach Code	Drop-in Wall Bracket	Drop-in Step
JMF 102	■	
JMF 104	■	■
JMF 106	■	■

*750mm deep or greater requires a step every 300mm

Contact us:

Head Office:
4 Silverwood Industrial Estate,
Lurgan, Co. Armagh,
BT66 6LN,
Northern Ireland

Telephone: +44 (0)28 38 313 100
Email: info@cubis-systems.com

www.cubis-systems.com



Driven by Innovation

Innovation is the engine that has driven Cubis Systems to its position as global leader in the design and manufacture of access chambers and cable ducting systems.

Inspired by innovation, we have developed quality products that replace traditional construction materials like bricks and concrete. Our lightweight plastics, incorporating intelligent design features, are used in the construction of infrastructure networks for the rail, telecoms, water, construction and power markets worldwide. Cubis products can be installed much faster than traditional methods and therefore save our customers both time and money.

Cubis manufactures the preformed STAKKAbox™ network access chamber systems, the AX-S™ access covers range, a MULTIduct™ multiple duct system and the PROtrough cable troughing system at sites throughout the UK and Ireland. These innovative products are exported to more than 29 countries throughout the world.

At Cubis we are committed to ongoing innovation and dedicated to delivering absolute product quality, detailed technical customer support and the highest levels of customer satisfaction.