

JTS3 K

THREE CORE HEATSHRINKABLE STRAIGHT THROUGH JOINT

INSTALLATION INSTRUCTION IM2175i - ed. 15/01/2020

TYPE OF CABLE: Solid insulation (XLPE-HEPR) STA/SWA armour
SECTION: 25 - 500 mm²
TYPE OF SCREEN: Copper tape screen
VOLTAGE: U_{max} 24 kV



1 THREE CORE CABLE PREPARATION

1.1

Straighten and set cables at the joint position.
 Determine the center of the joint and cut the cables with a 200 mm overlap.
 Clean the cable for 2 m at both sides.
 Slide the two heatshrinkable end tubes "GT3" along each cable.
 Slide the heatshrinkable central tube "GT8" along one of the cable.
 Slide these tubes up to the position where the jointing work will not be disturbed.

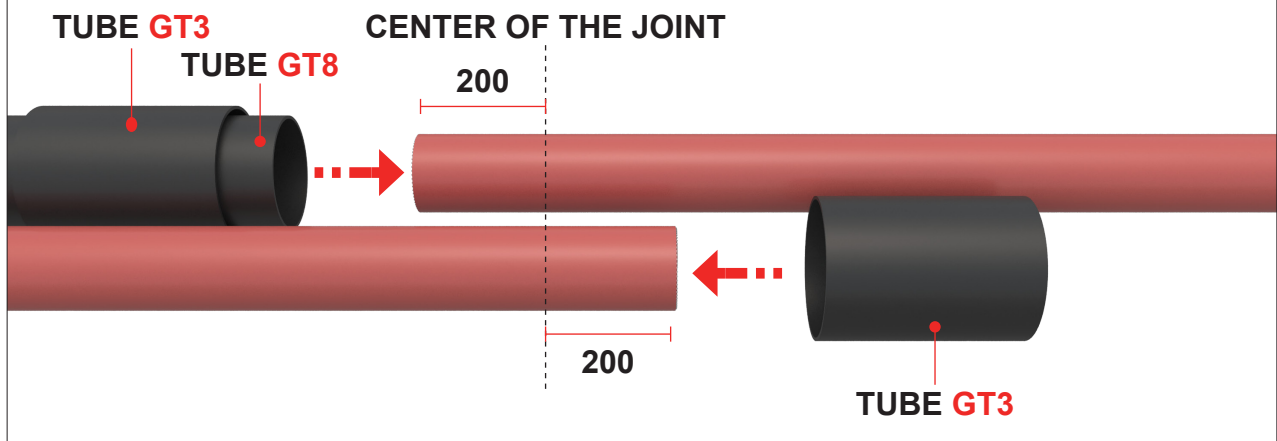

1.2

Remove the outer sheath for the length "Y+200 mm" (short stripping side) and for the length "Y1+200 mm" (long stripping side).
 Abrade the outer sheath for 200 mm at both sides. Clean the abraded area.

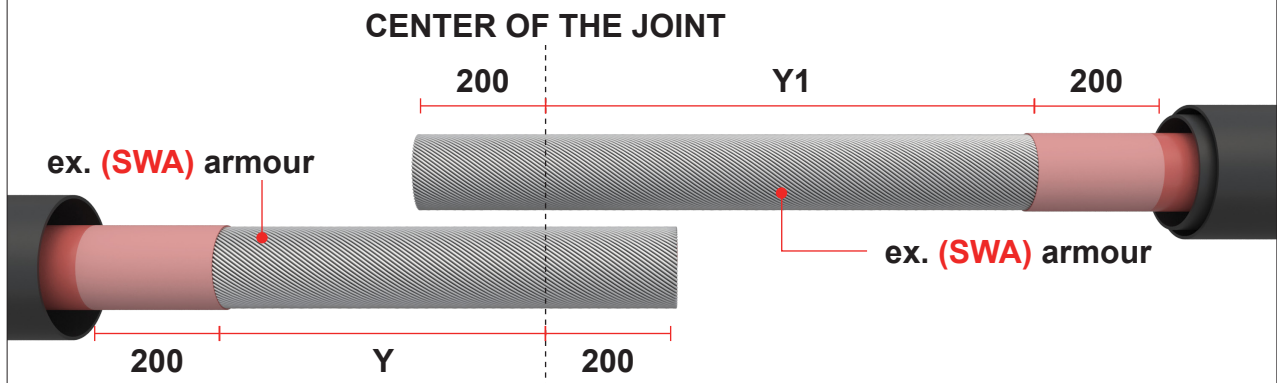

	Length of GT125 "triple wall" tube	Y	Y1
	300 mm	450 mm	750 mm
	350 mm	450 mm	750 mm
	400 mm	550 mm	850 mm

1.3

Position the metallic clamp at 80 mm from cut outer sheath and cut the armour.

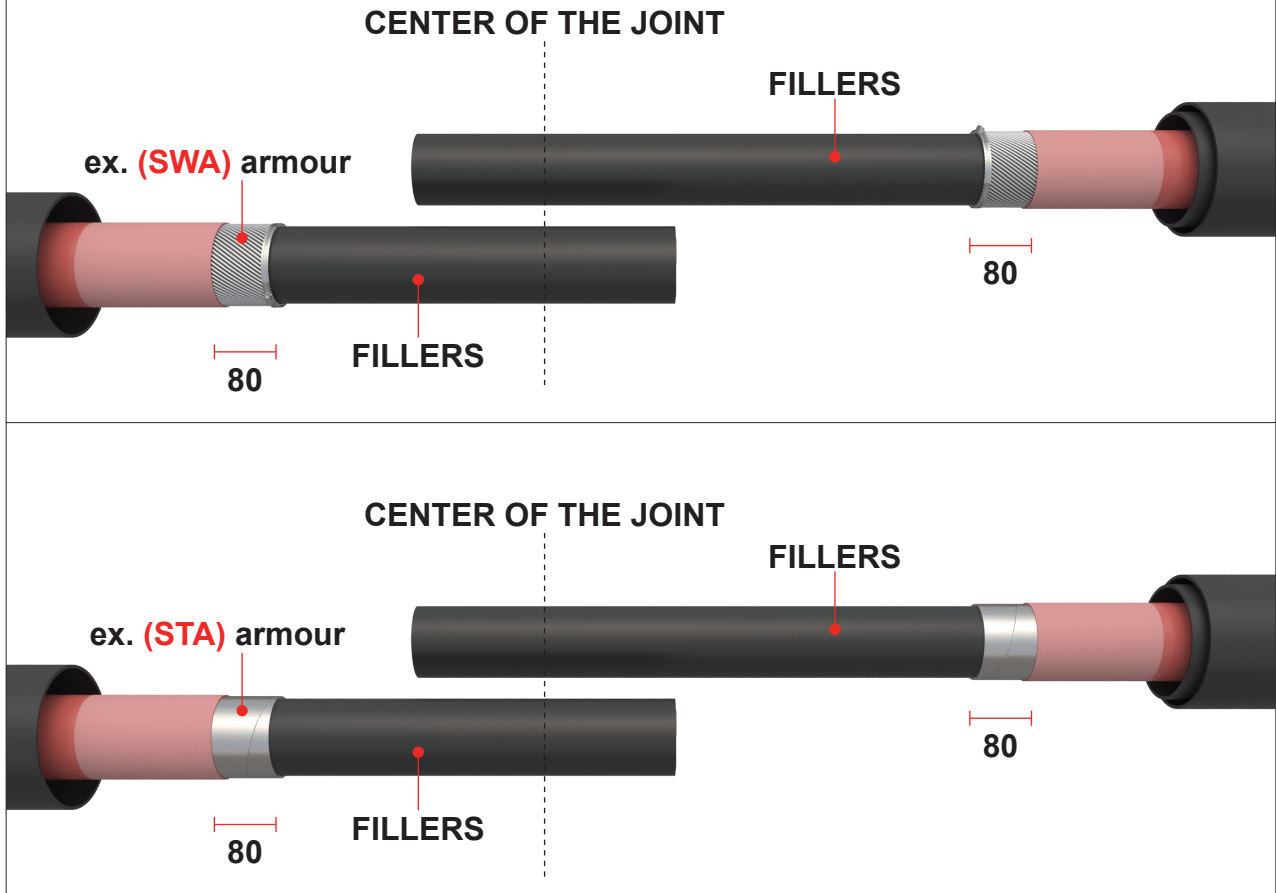

1.4

Cut the eventual PVC inner sheath and fillers leaving 5 mm out of the armour.

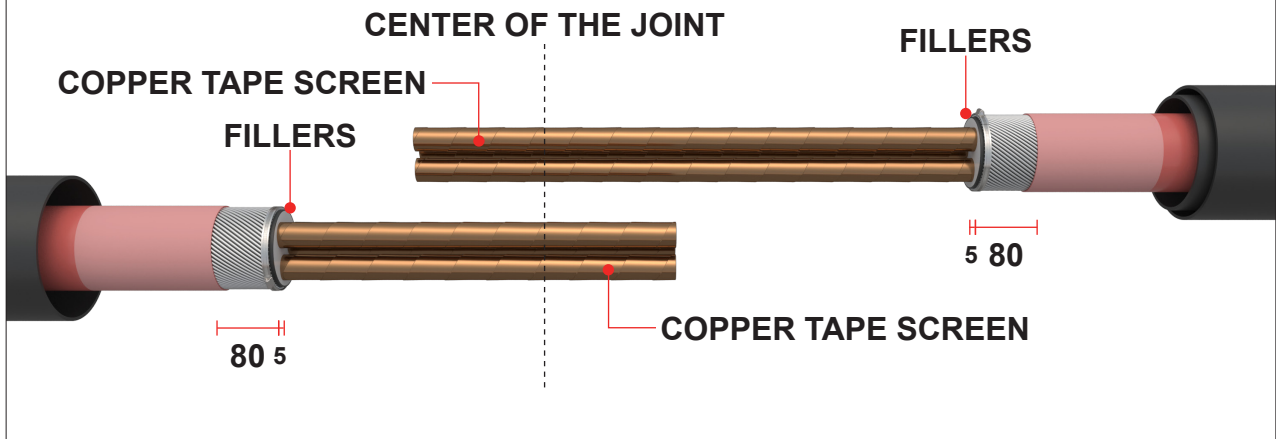

● 1.5

Fix the edges of screen tapes with some PVC tape to prevent unwinding.

● 1.6

ONLY FOR CABLES WITH STEEL WIRES ARMOUR:

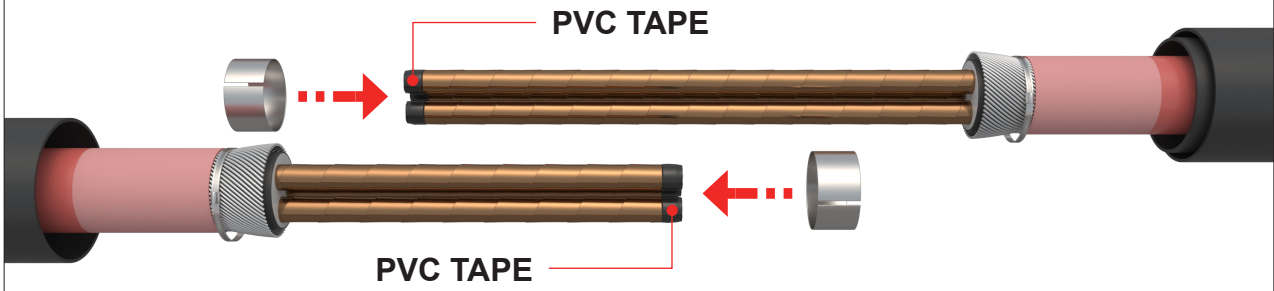

Loose the metallic clamp, open the armour wires and insert the under armour ring.

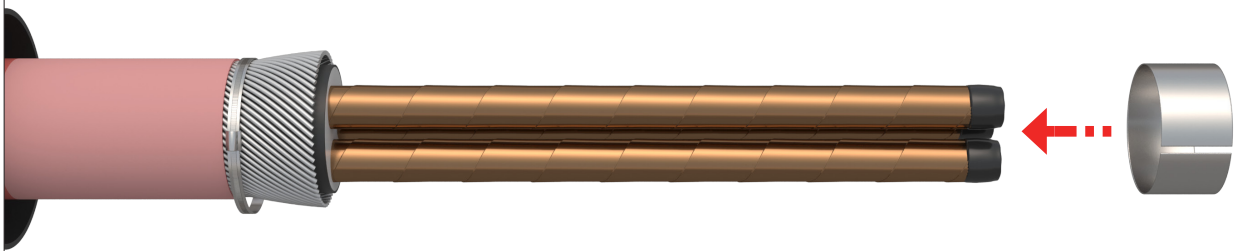

Close the armour wires.

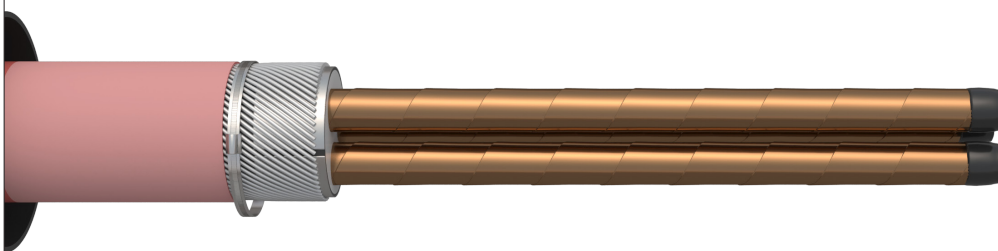

Secure with NCV tape.

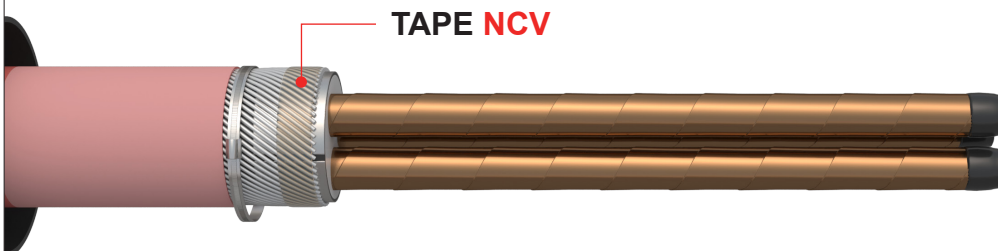

● 1.7

Shape the cable cores.

Remove the copper tape screen for the distance "H" from the center of the joint.

Fix the extremities of each tape screen with some PVC tape or copper adhesive tape (if supplied) to avoid unwinding.

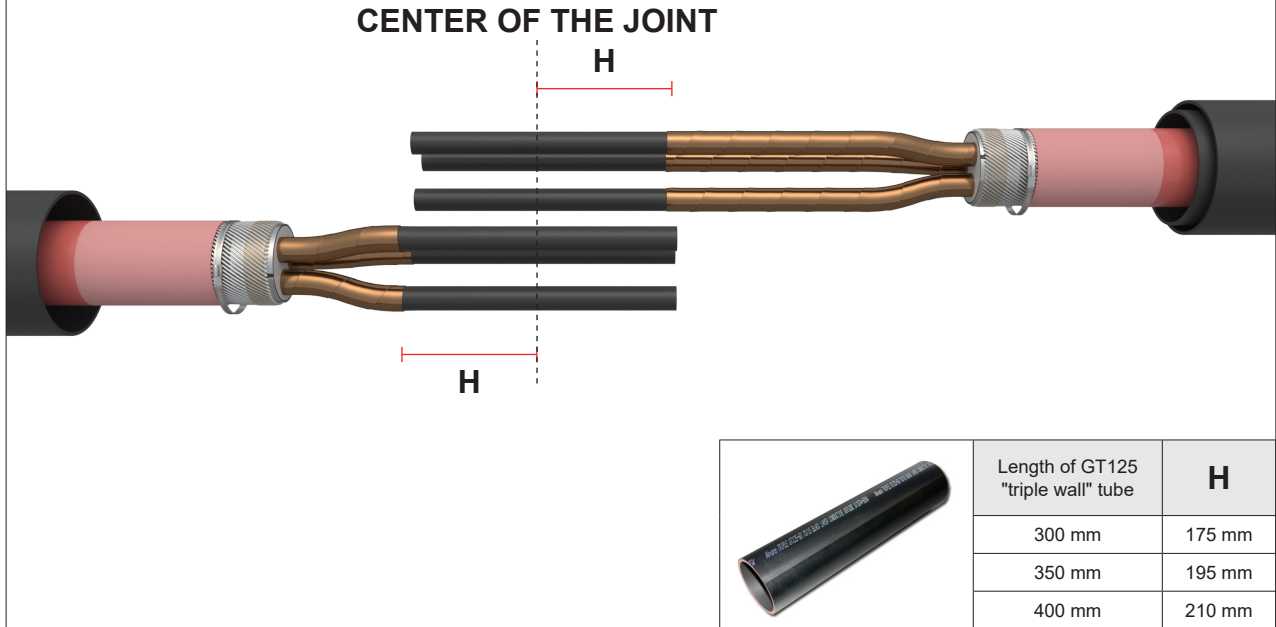

● 1.8

Cut the cable cores at the reference line. (Center of the joint).

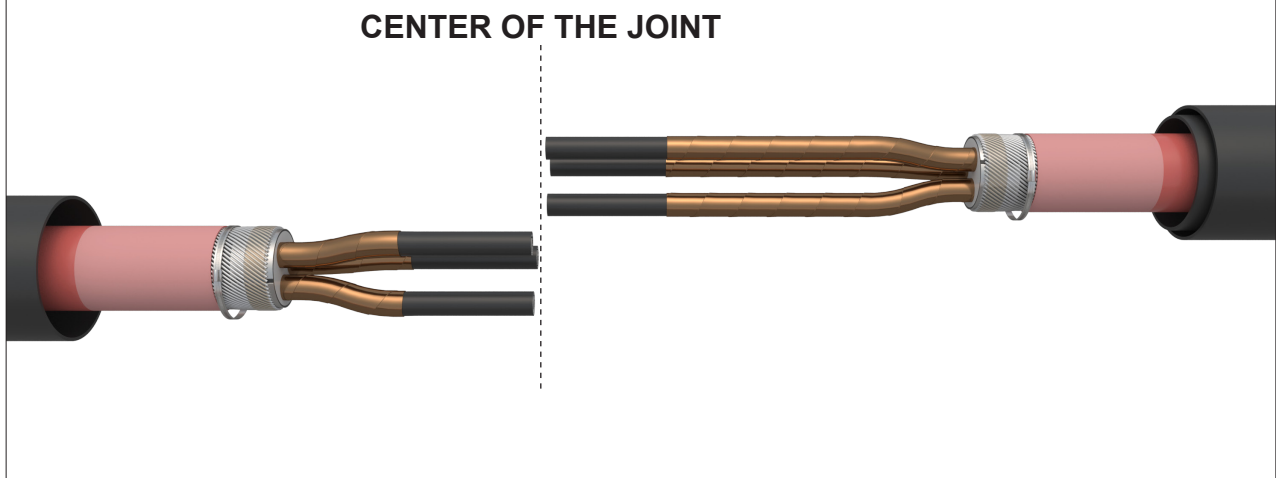

● 1.9

Remove the semiconductive layer leaving 50 mm from the metallic screen.
Take care not to damage the insulation.

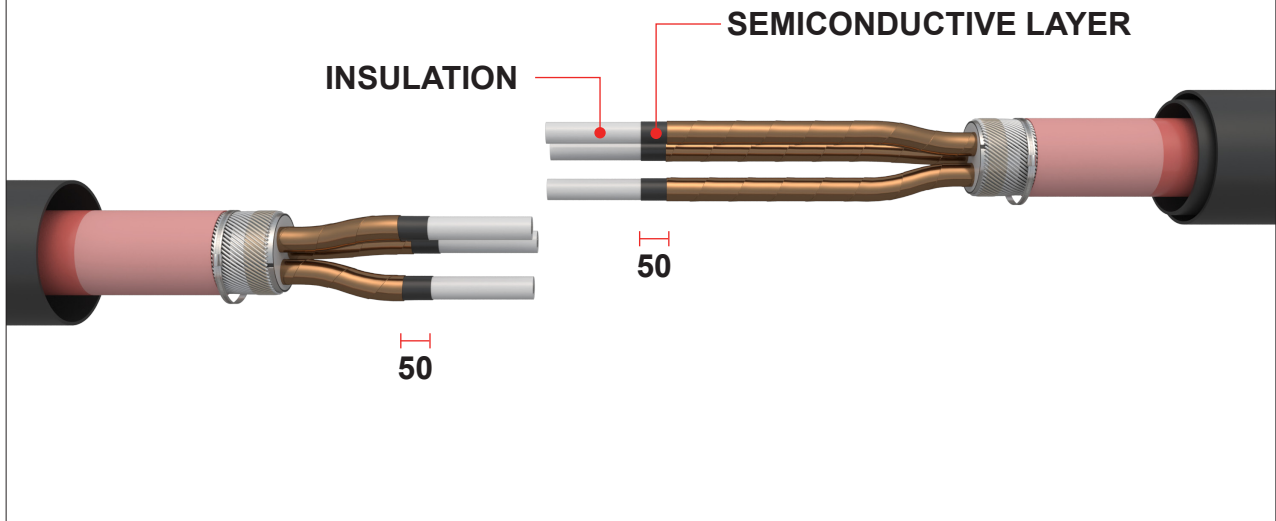

● 1.10

Bare the conductor for a length of inside depth of the connector for mechanical types or, in case of compression ones, for a length of inside depth of the connector + 5 mm.

Clean and degrease the conductor.

As a protection, wrap few turns of adhesive tape around the conductor end (LONG STRIPPING SIDE).

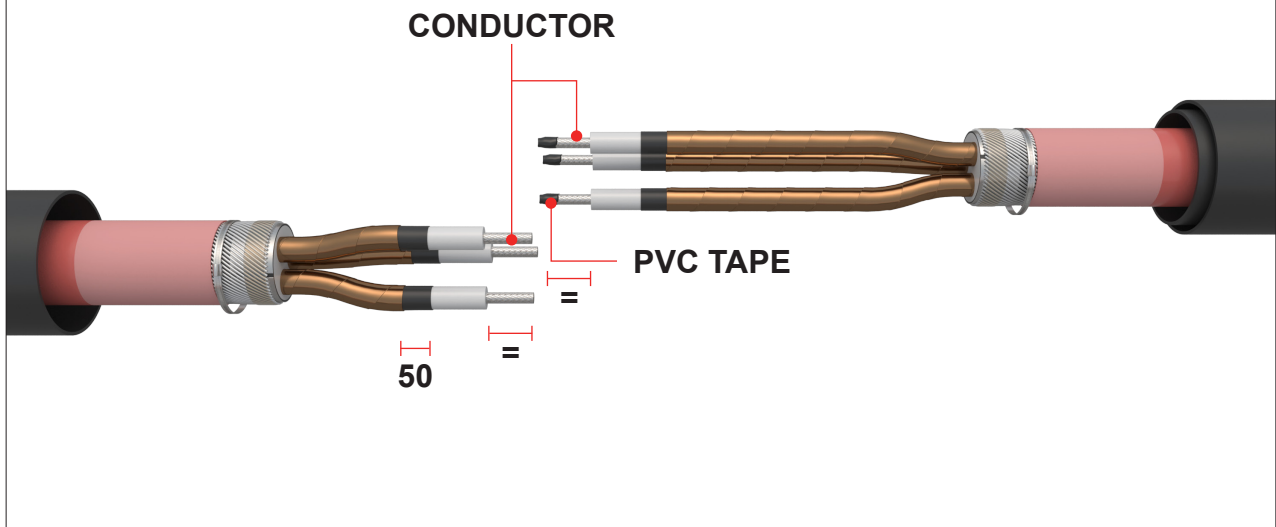

● 1.11

Slide the copper stocking meshes into the cable on THE LONG STRIPPING SIDE of the joint.

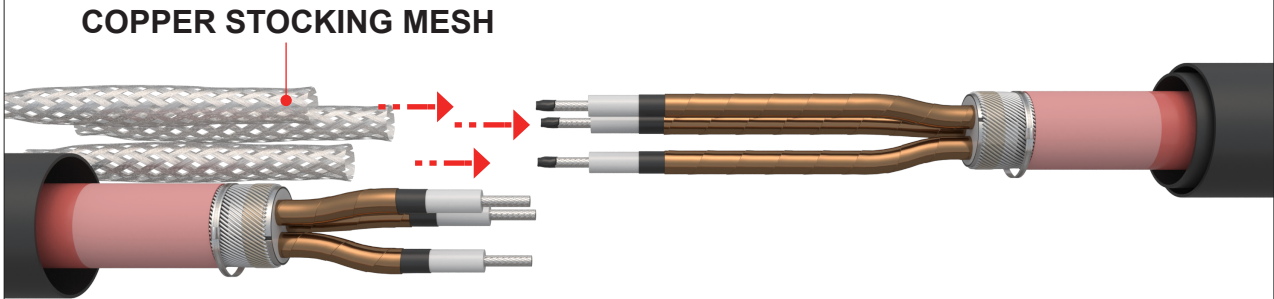

Slide the triple wall tubes into the cable on the LONG STRIPPING SIDE of the joint.

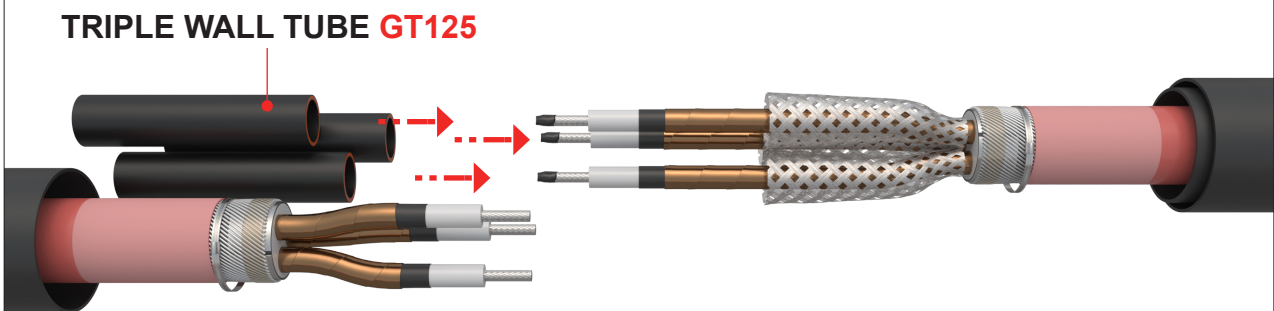

2 ASSEMBLY OF THE JOINT

2.1

Remove the tape PVC applied on the conductor.

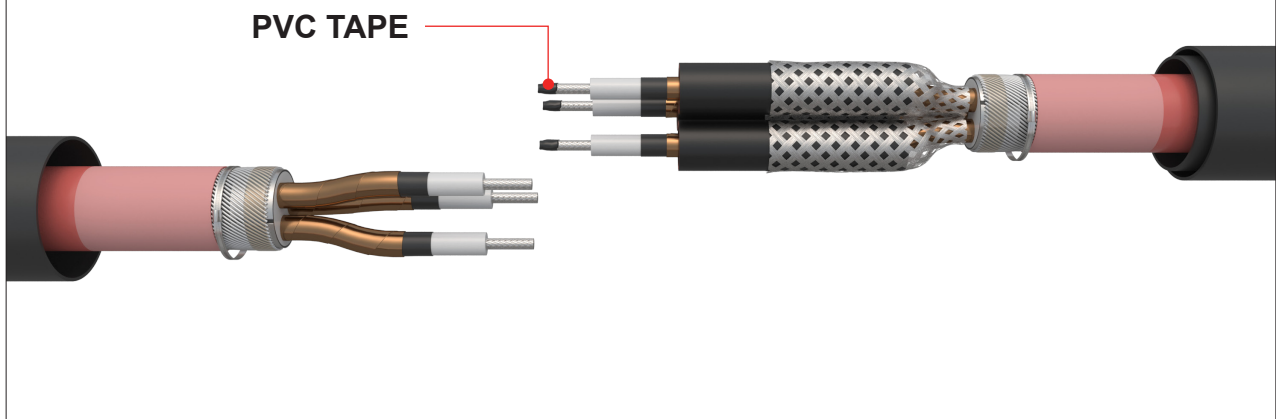

2.2

Install the connector onto the cable cores as per the manufacturer's instructions. If using hexagonal compression connectors ensure that any sharp edges and flashing are removed from the connector with a file or abrasive cloth. If using mechanical connectors make sure any indents left after shearing the bolts are filled with "CLAY" mastic.

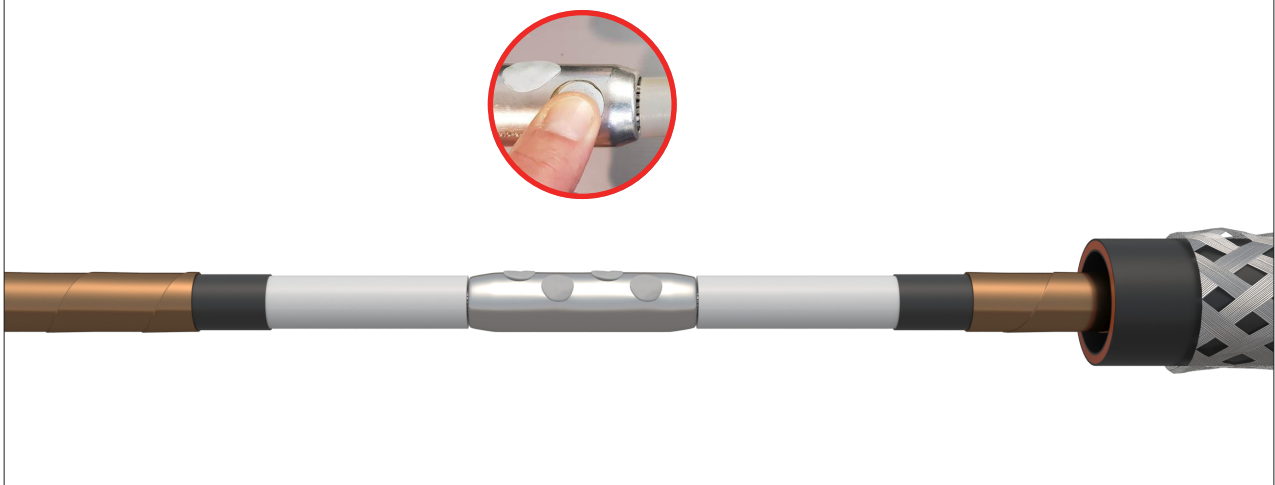

2.3

Wrap the mastic patch around the connector area, centering the patch over the connector with equal distance at both sides. Do not squeeze the extremities.

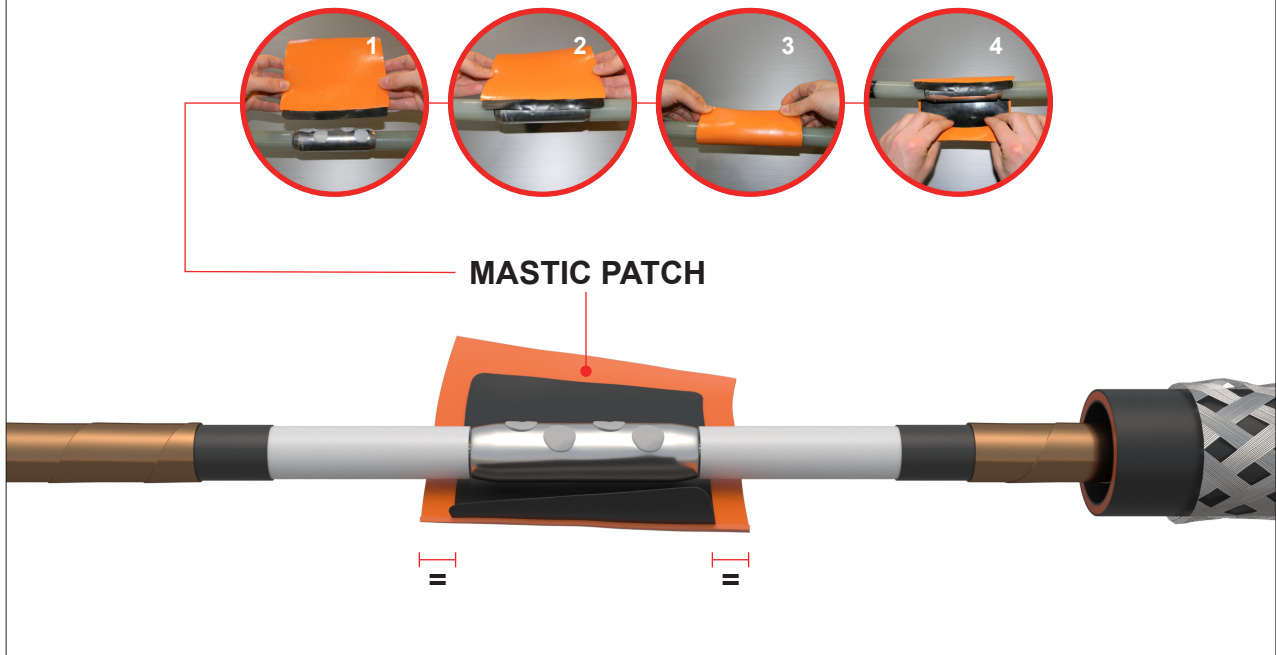

2.4

Apply a layer of stress relief mastic "OM" overlapping the semiconductive layer and the insulation of the cable (short mastic strip).

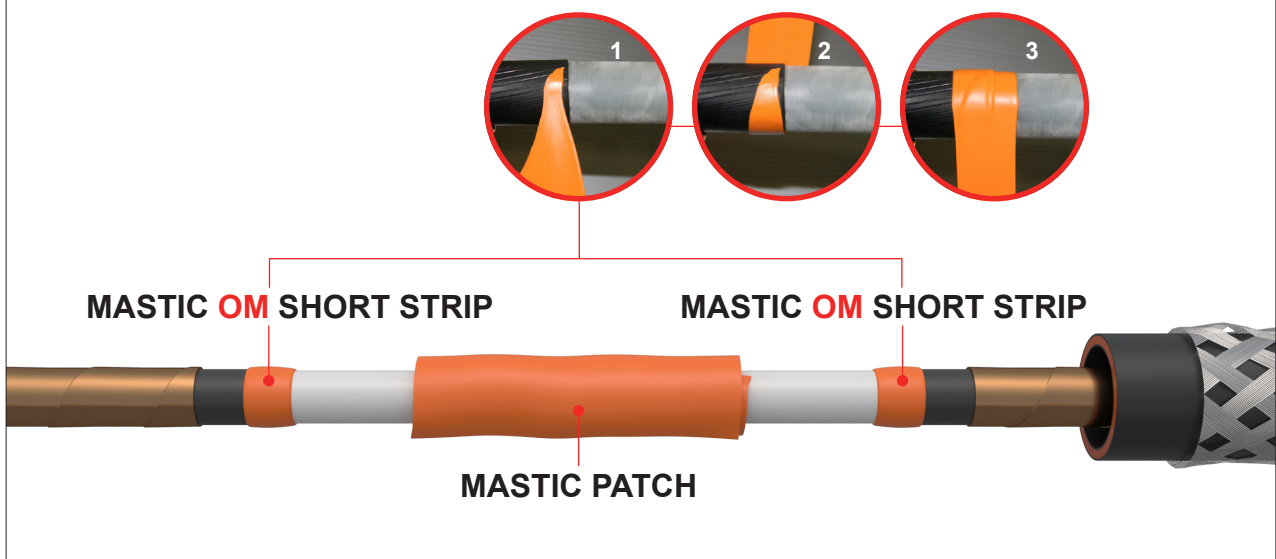

2.5

Position the triple wall tube "GT125" in the centre of the joint, pre-heat the tube for a minute and start shrinking from the centre towards to the extremities.

- To avoid over-heating of the heatshrinkable tube, keep the flame moving continuously and mantail ad adeguata distanza with the angle of 45°.
- Heatshrink the tube from the center until obtaining a smooth surface.
- Continue the heatshrinking for circular sector of 100 mm alternating itself from both sides.
- At the end of the work, the surface of the heatshrinkable tube must be smooth.

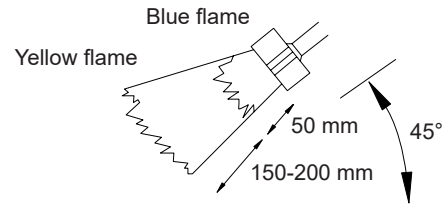

TRIPLE WALL TUBE GT125

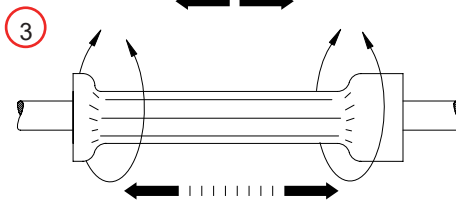
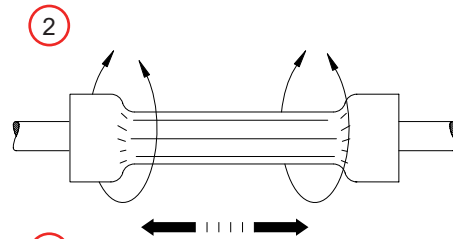
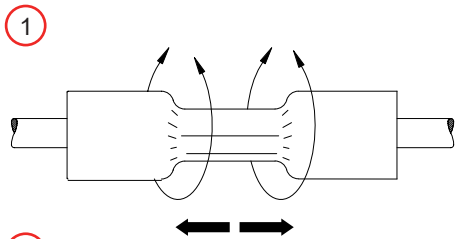
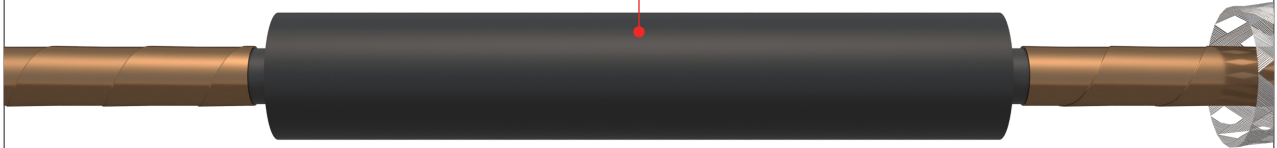
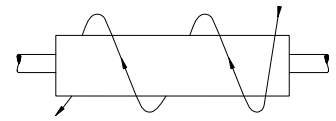

● 2.6

Slide and position the copper stocking mesh, fix the stocking mesh to the copper tape screen with the constant roll force springs.

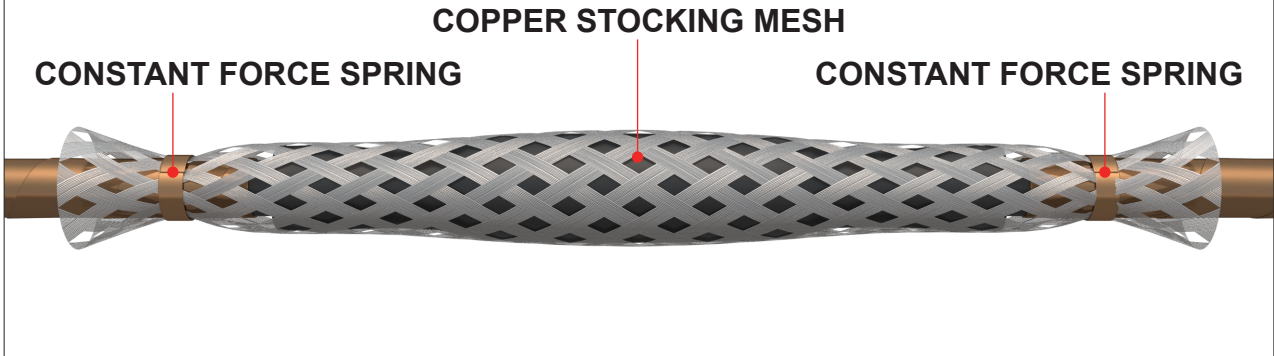

● 2.7

Apply some PVC tape over the constant roll force springs.



● 2.8

Fold back the stocking mesh exceeding towards the centre of the joint.
Apply some PVC tape over the edge of stocking mesh.



2.9

Wrap around the whole joint the earthing braid and fix to the armour and to the tape screen with a binding of tinned copper wire.
Wrap around the cores with "NCV" reinforcing tape.

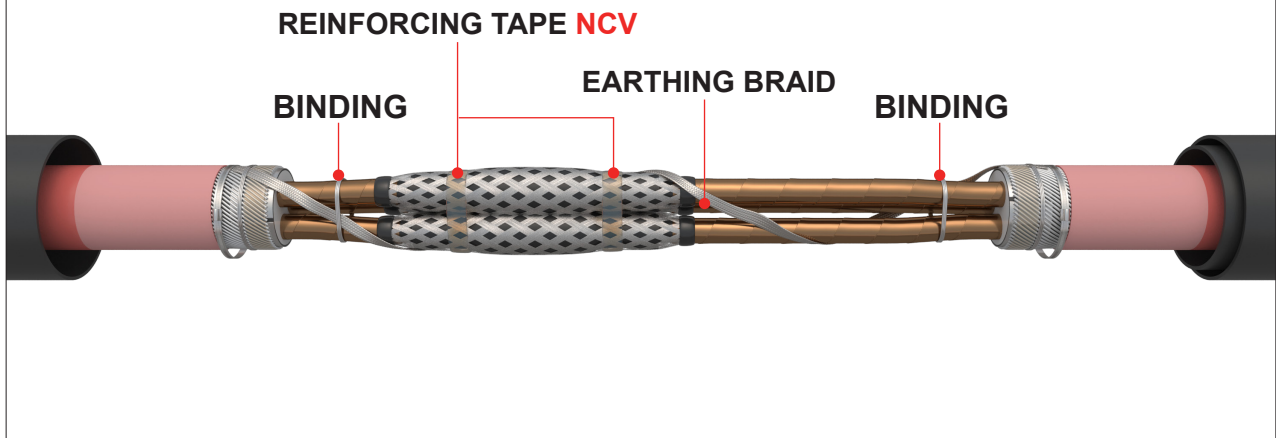

2.10

Clean the abraded area of the outer sheath.
Wrap around the metallic protection and position centrally over the jointing area.

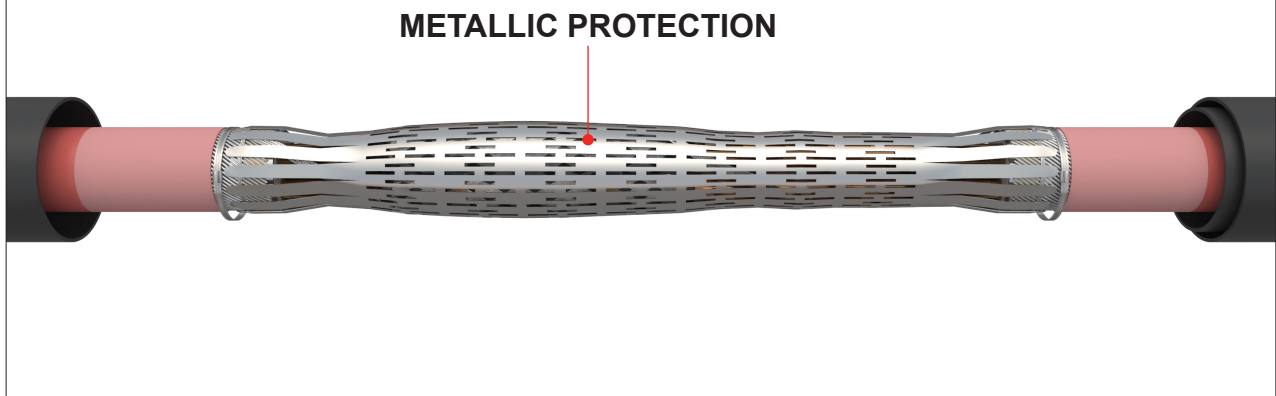

● 2.11

Wrap around the rolled mechanical protection some layers of NCV reinforcing tape
At both ends bend the fingers. Secure to the armour with metallic clamps. (TO BE PROPERLY TIGHTENED).

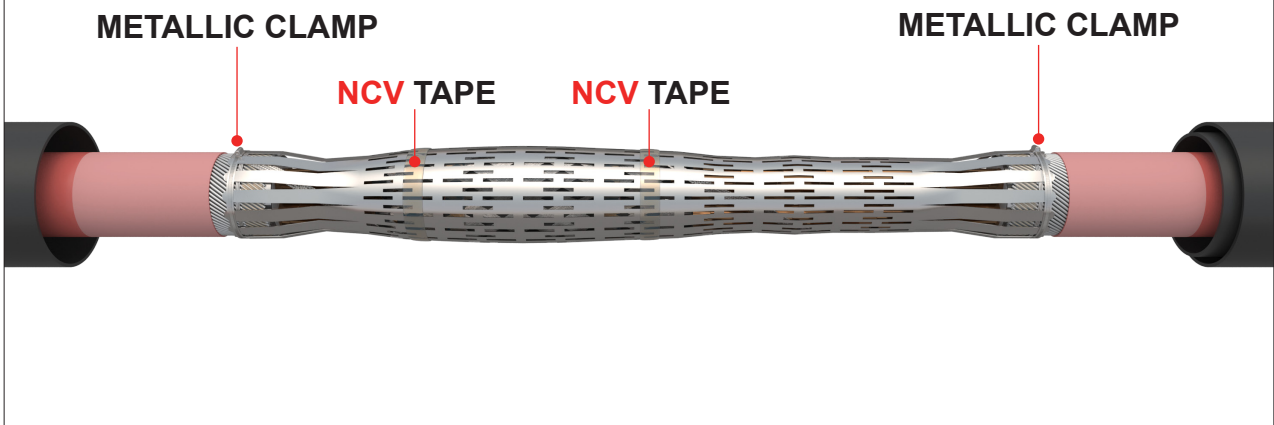

● 2.12

Apply a layer of sealing mastic tape "NGAF" (50% overlap) over the clamps
till covering the outer sheath for 15 mm.

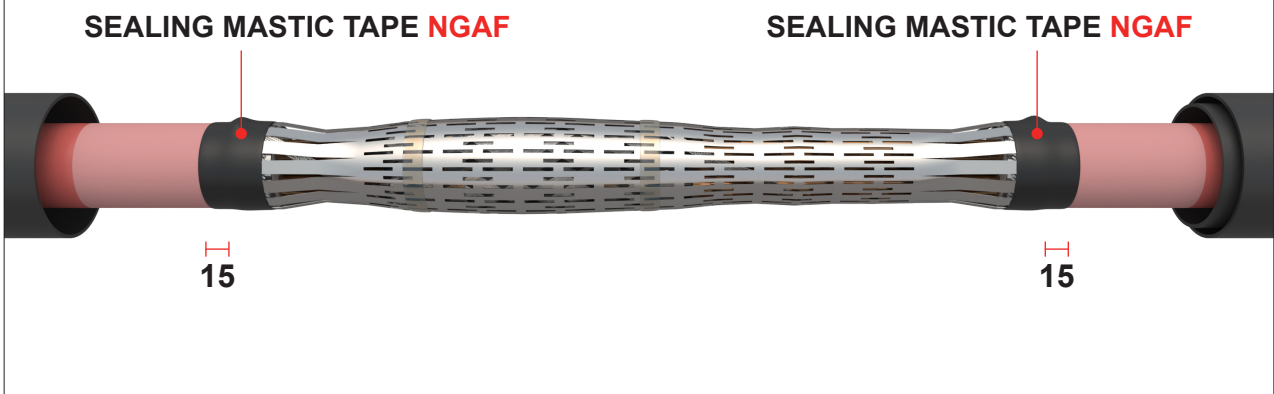

2.13

Slide the outer central tube "GT8" into position ensuring equal distance at both sides.
Start heatshrinking from the centre towards the extremities.

- To avoid over-heating of the heatshrunkable tube, keep the flame moving continuously and maintain an adequate distance with the angle of 45°.
- Heatshrink the tube from the center until obtaining a smooth surface.
- Continue the heatshrinking for circular sector of 100 mm alternating itself from both sides.
- At the end of the work, the surface of the heatshrunkable tube must be smooth.

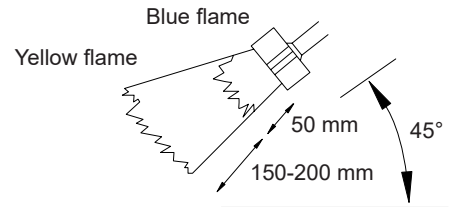

OUTER PROTECTION CENTRAL TUBE GT8

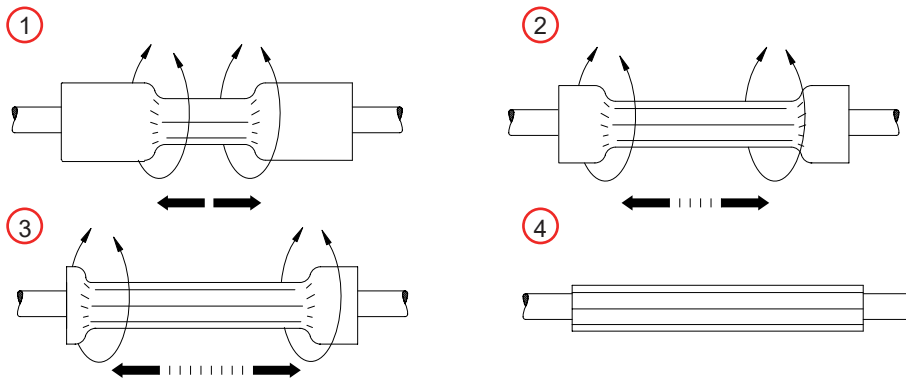
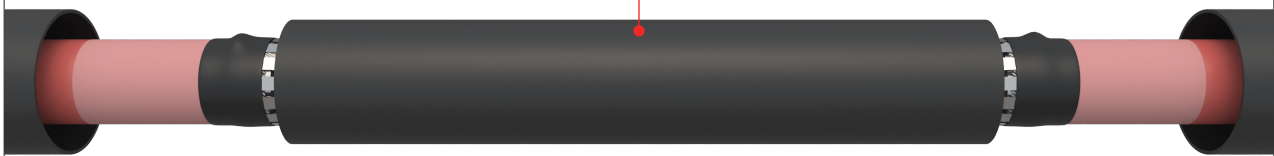

● 2.14

Slide the end tubes "GT3" overlapping the shrunk outer central tube for equal distance, taking care to heatshrink starting from the external side towards the centre of the joint.

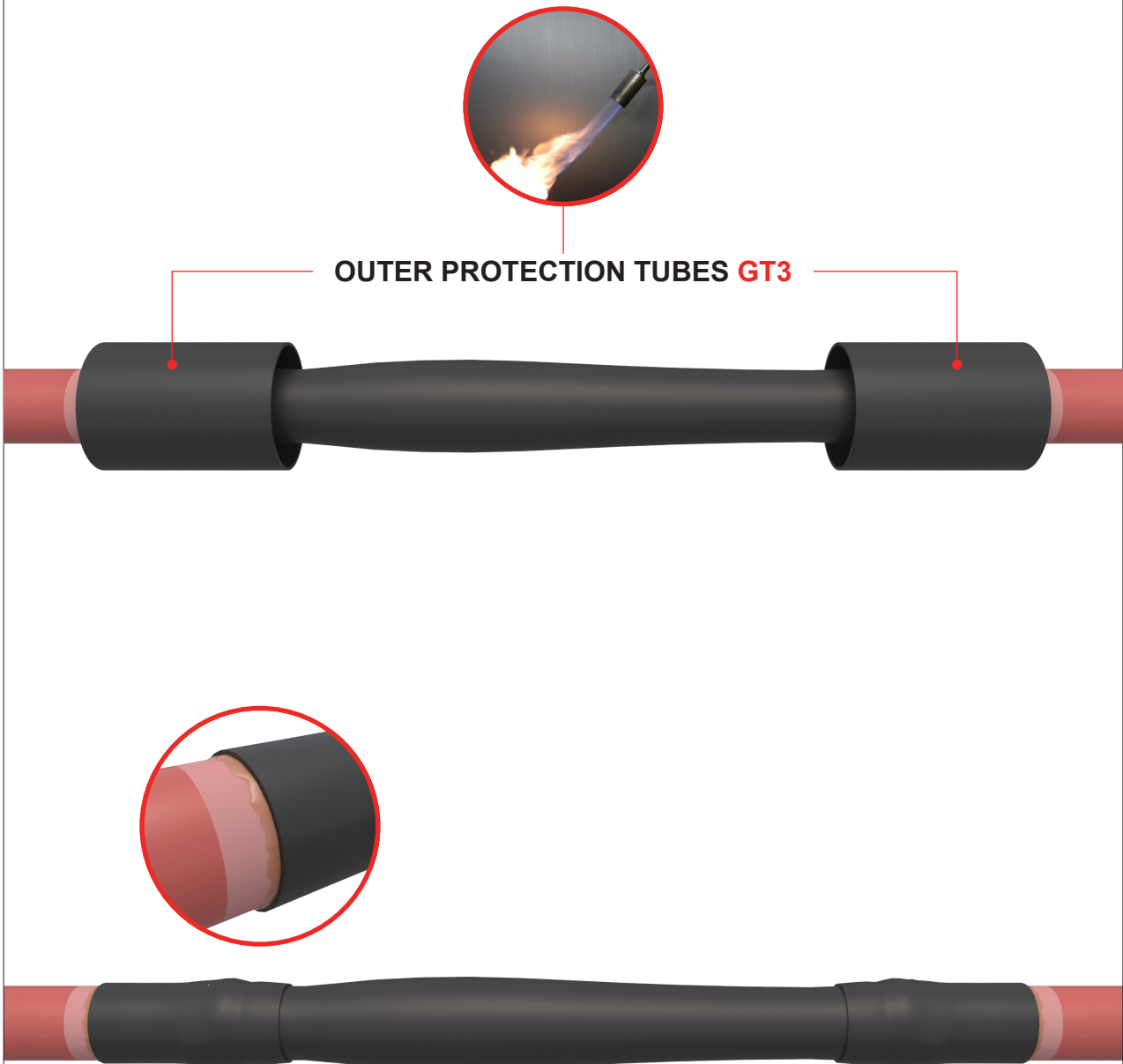

The joint is complete. Allow to cool before moving.

Adjust torch to give a soft blue flame with yellow tip.
Heatshrink tubes uniformly avoiding wrinkles along the surface.
Keep the flame moving continuously and maintain adequate distance to avoid over heating.

This product should be installed by competent personnel familiar with electrical equipment and safe operating practices. Parts contained in this kit should be visually inspected for possible damage, and installed in accordance with these instructions. These instructions are not intended as a substitute for adequate training and experience.



Please dispose of all waste according to environmental regulations.

The company reserves the right to alter without notice the information contained in this installation manual.

Nexans Italia S.p.A.

nexans.com/power_accessories
sales.npai@nexans.com

