

GTS1

HEAT-SHRINKABLE SINGLE CORE XLPE STRAIGHT JOINT

Up to 36 kV

6/10 (12) kV
6.35/11 (12) kV
8.7/15 (17.5) kV
12/20 (24) kV
12.7/22 (24) kV
18/30 (36) kV
19/33 (36) kV

Application

For jointing polymeric cable to be laid in air or directly buried. The product is fully screened and fully submersible.

Design

1. Dual wall tube.
2. Stress control tube.
3. Stress control mastic.
4. Non-tracking tube (only for 36GTS1).
5. Overall protection tube.
6. Sealing mastic.
7. Screen continuity (copper mesh).
8. Conductor connector (supplied on request).
9. Ferrule for screen wires.

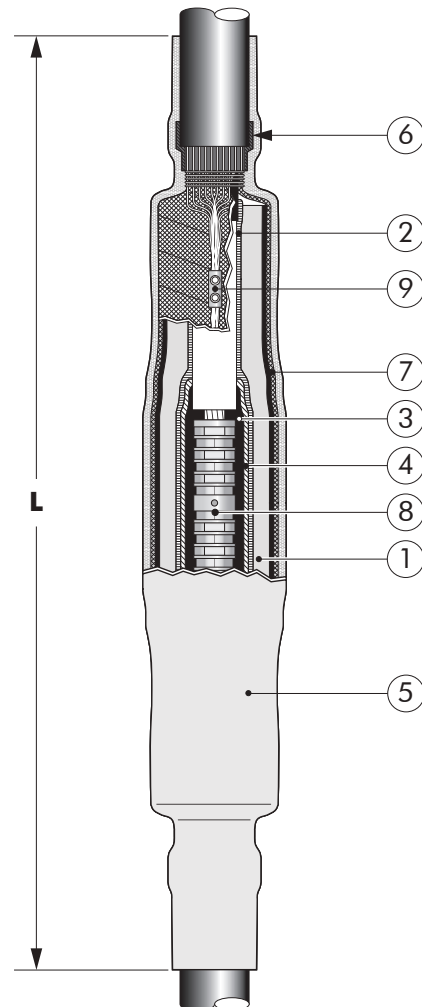

Specifications and standards

Meets the requirements of CENELEC HD 629.2 and IEC 60502-4.

Straight Joint type	Voltage U_m (kV)	Length "L" (mm)	Conductor sizes (mm ²)	
			min	max
17GTS1	12 & 17.5	600 - 750	25	630
24GTS1	24	600 - 750	25	630
36GTS1	36	750 - 1000	35	800

08/2011

Kit contents

The complete GTS1 joint kit comprises the following components:

The kit also comprises installation instructions, semi-conductive tape, adhesive tape, a copper braid and a ferrule for the screen wire connection.

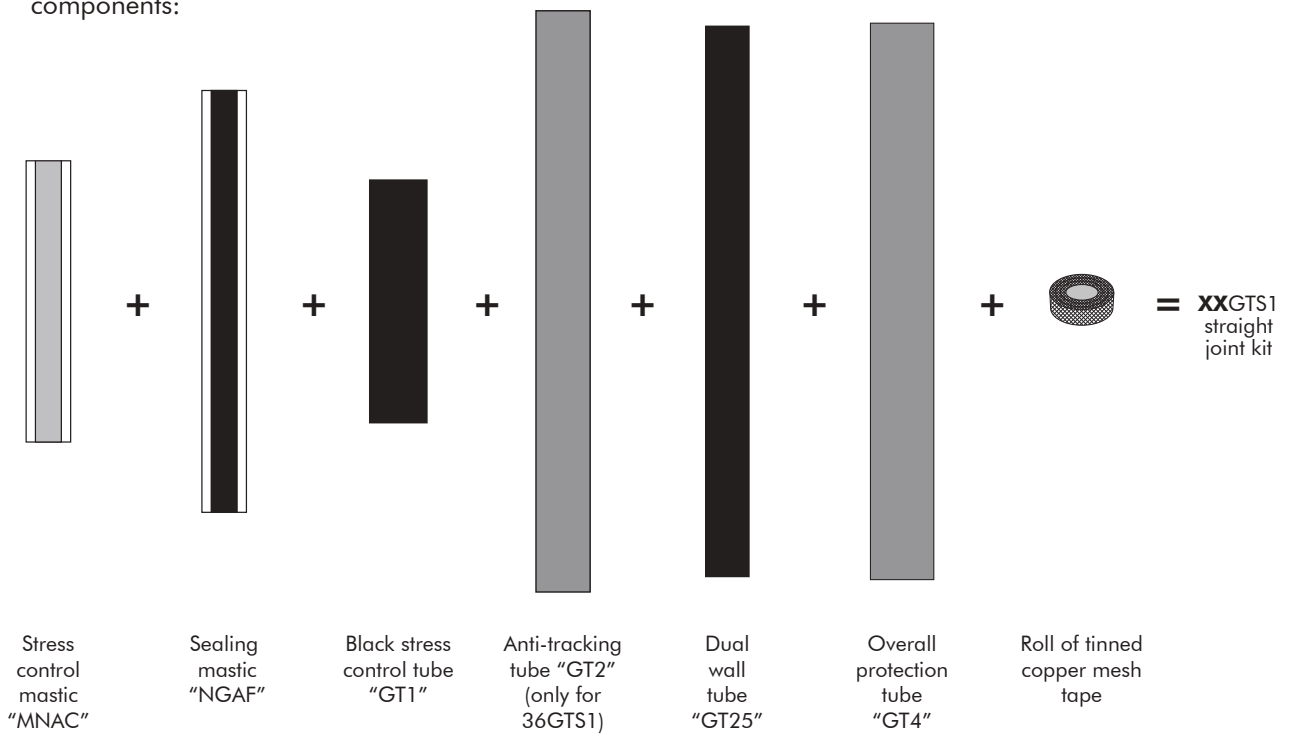

Ordering instructions

Select the part number corresponding to both system voltage and conductor size.

Example:

The copper wire screened cable is 12 kV, 150 mm² stranded aluminium.
Order: 17GTS1.240w.

Ordering part number	Voltage U ₀ /U (kV)	Conductor size range (mm ²)	
		min	max
17GTS1.50w	6/10 & 6.35/11 & 8.7/15	25	50
17GTS1.95w	6/10 & 6.35/11 & 8.7/15	50	95
17GTS1.240w	6/10 & 6.35/11 & 8.7/15	95	240
17GTS1.630w	6/10 & 6.35/11 & 8.7/15	240	630
17GTS1.1000w	6/10 & 6.35/11 & 8.7/15	630	1000
24GTS1.50w	12/20 & 12.7/22	25	50
24GTS1.240w	12/20 & 12.7/22	35	240
24GTS1.400w	12/20 & 12.7/22	150	400
24GTS1.630w	12/20 & 12.7/22	300	630
24GTS1.1000w	12/20 & 12.7/22	630	1000
36GTS1.95i	18/30 & 19/33	35	95
36GTS1.240i	18/30 & 19/33	70	240
36GTS1.500i	18/30 & 19/33	185	500
36GTS1.800i	18/30 & 19/33	500	800
36GTS1.1200i	18/30 & 19/33	630	1200

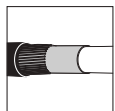

For use with copper wire screened cables. No further earthing device is necessary.

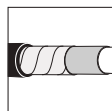

For use with copper tape screened cables. Order: -Aw/-Ai instead of -w/-i (e.g. 17GTS1.240Aw).



For use with other cable types. Please contact our representative.



For use with three-core cables: see GTS3.

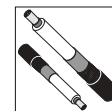

When jointing cables of different sizes, please contact our representative.

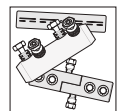

Can be supplied with all common types of conductor connectors.



THORNE & DERRICK
INTERNATIONAL

Thorne & Derrick
+44 (0) 191 410 4292
www.powerandcables.com